

# Propulsion

(According to the Syllabus Prescribed by  
Director General of Civil Aviation, Govt. of India)



**FIRST EDITION**

# **PROPULSION**

**Prepared by**

*L.N.U.M. Society Group of Institutes*

\* *School of Aeronautics*

(Approved by Director General of Civil Aviation, Govt. of India)

\* *School of Aeronautics (Neeurana)*

(Approved by Director General of Civil Aviation, Govt. of India)

**Compiled by**

*Arjun Singh*

**Published By**

*L.N.U.M. Society Group of Institutes*

**H-974, Palam Extn., Part-1, Sec-7, Dwarka, New Delhi-110070**

**Published By**

*L.N.U.M. Society Group of Institutes,*  
Palam Extn., Part-1, Sec.-7,  
Dwarka, New Delhi - 110070

**First Edition 2012**

All rights reserved; no part of this publication may be reproduced, stored in a retrieval system or transmitted in any form or by any means, electronic, mechanical, photocopying, recording or otherwise, without the prior written permission of the publishers.

Price : Rs. 400/-

**Type Setting**

*Sushma*

**Cover Designed by**

*Abdul Aziz*

**Printed at Graphic Syndicate, Naraina, New Delhi**

**Dedicated To**

*Shri. Laxmi Narain Verma*  
**[ Who Lived An Honest Life ]**

# **Preface**

This book is intended as an introductory text on Aero Engine which is an essential part of General Engineering and Maintenance Practices of DGCA license examination.

It is intended that this book will provide basic information on principle, fundamentals and technical procedures in the subject matter areas relating to the Aero Engines.

The written text is supplemented with large number of suitable diagrams for reinforcing the key aspects.

In Einstein's word "Make things as possible but no simpler". No doubt he had textbook authors in mind. Only a few books find the narrow path between overwhelming the reader and wasting the reader's time. I believe that this is one of those rare books that find that path.

I acknowledge with thanks the contribution of this faculty and staff of L.N.V.M. Society Group of Institutions for their dedicated efforts to make this book Aero Engine a success.

I am also thankful to our Director Mr. C.C. Ashoka for having faith on me in publishing this book.

I would very much appreciate criticism, suggestions for improvement and detection of errors from the readers, which will be gratefully acknowledged.

**Arjun Singh**

(Senior Instructor, School of Aeronautics)

# CONTENTS

|     |  |    |
|-----|--|----|
| 1.  | JET ENGINE   | 01 |
| 2.  | STARTING AND IGNITION SYSTEMS (TURBINE ENGINES)    | 37 |
| 3.  | LUBRICATION SYSTEM : GAS TURBINE ENGINE            | 42 |
| 4.  | VENTILATION AND COOLING SYSTEM                     | 46 |
| 5.  | THRUST REVERSER                                    | 50 |
| 6.  | FUEL SYSTEM (TURBINE ENGINES)                      | 55 |
| 7.  | ELECTRONIC ENGINE CONTROL AND FUEL METERING SYSTEM | 61 |
| 8.  | CONSTRUCTION AND OPERATION OF PROPELLERS           | 68 |
| 9.  | ANTIICING OF GAS TURBINE ENGINE                    | 75 |
| 10. | STORAGE OF PISTON AND GAS TURBINE AERO ENGINE      | 79 |
| 11. | ENGINE INDICATING SYSTEM PART-I                    | 82 |
| 12. | ENGINE INDICATING SYSTEM PART-II                   | 90 |



# CHAPTER - 1

## JET ENGINES

### PRINCIPLE OF JET PROPULSION

Jet propulsion is a practical application of Sir Issac Newton's third law of motion which states that for every force acting on the body there is an opposite and equal reaction for aircraft propulsion, the "body" is atmosphere air that is caused to accelerate as it passes through the engine. The force required to give this acceleration has an equal effect in the opposite direction acting on the apparatus producing the acceleration. The jet engine produces thrust in a similar way to the propeller/engine combination, but where as the propeller gives a small acceleration to a large weight of air, the jet engines gives a large acceleration to small weight of air.

The familiar whirling garden sprinkler is a more practical example of this principle, for the mechanism rotates by virtue of the reaction to the water jets.

Jet reaction is definitely an internal phenomenon and does not, as is frequently assumed, result from the pressure of the jet on the atmosphere. In fact the jet propulsion engine, whether rocket, athodydes or turbojet is a piece of apparatus designed to accelerate a large stream of air and to expel it at an exceptionally high velocity. There are of course a number of ways of doing this but in all instances the resultant reaction or thrust exerted on the engine is proportional to the mass of air expelled by the engine and to the velocity change imparted to it. In other words, the same thrust can be provided either by giving a large mass of air a little extra velocity or a small mass of air, a large extra velocity.

### METHODS OF JET PROPULSION

The types of jet engines, whether ram jet, pulse jet, rocket gas turbine, turbo/ram jet or turbo-rocket differ only in the way in which the thrust provider or engine, supplies and converts the energy into power for flight.

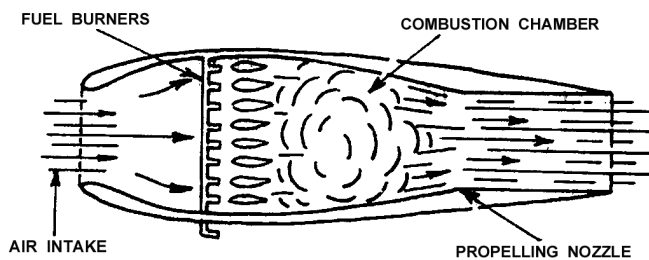

Fig.1.1 Ram Jet Engine.

### Ram Jet

A Ram jet engine is an athodyde or aerothermodynamic duct to give it its full name. It has no major rotating parts and consists of a duct with a divergent entry and a convergent or convergent-divergent exit. When forward motion is imparted to it from an external source, air is forced into the air intake where it loses velocity or kinetic energy and increases its pressure energy as it passes through the divergent duct. The total energy therefore, increased by the combustion of fuel, and the expanding gases accelerate to atmosphere through the outlet duct. A ram jet is often the power plant for missiles and target vehicles, but is unsuitable as an aircraft power plant because it requires forward motion imparting to it before any thrust is produced.

### Pulse Jet

A pulse jet engine uses the principle of intermittent combustion and unlike the ram jet it can be run at a static condition. The engine is formed by an aerodynamic duct similar to the ram jet but due to higher pressure involved, it is of more robust construction. The duct inlet has a series of inlet valves that are spring loaded into the open position. Air drawn through the open valves passes into the combustion chamber and is heated by the burning of fuel injected into the chamber. The resulting expansion causes the rise in pressure, forcing the valves to close, and the expanding gases are therefore ejected rearwards. A depression created by the exhausting gases allows the valve to open and repeat the cycle. Pulse jets have been designed for helicopter rotor propulsion and some dispense with inlet valves by careful design of the ducting

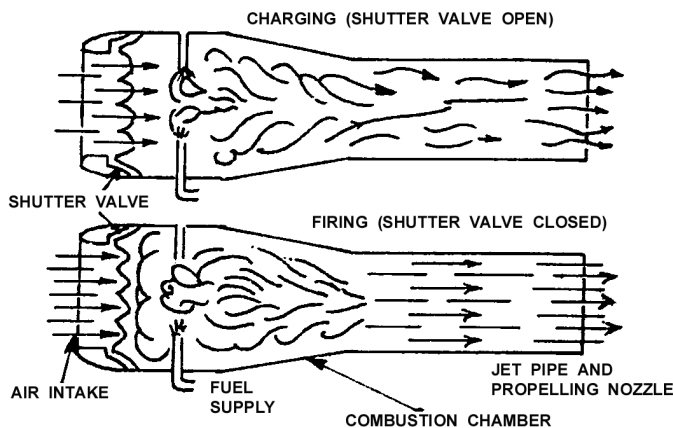

Fig. 1.2. Pulse Jet.



to control the changing pressure of the resonating cycle. The pulse jet is unsuitable as an aircraft power plant because it has a high fuel consumption and is unable to equal the performance of the modern gas turbine engine.

### Rocket Engine

Although a rocket engine is a jet engine, it has in that it does not use atmosphere air as the propulsive fluid, stream. Instead it produces its own propelling fluid by the combustion of liquid or chemically decomposed fuel with oxygen, which it carries, thus enabling it to operate outside the earth's atmosphere. It is therefore only suitable for operation over short periods.

### TYPES OF JET ENGINES (GAS TURBINE)

The gas turbine engine is basically of simple construction although the thermal and aerodynamic problems associated with its design are some what complex. There are no reciprocating components in the main assembly and the engine

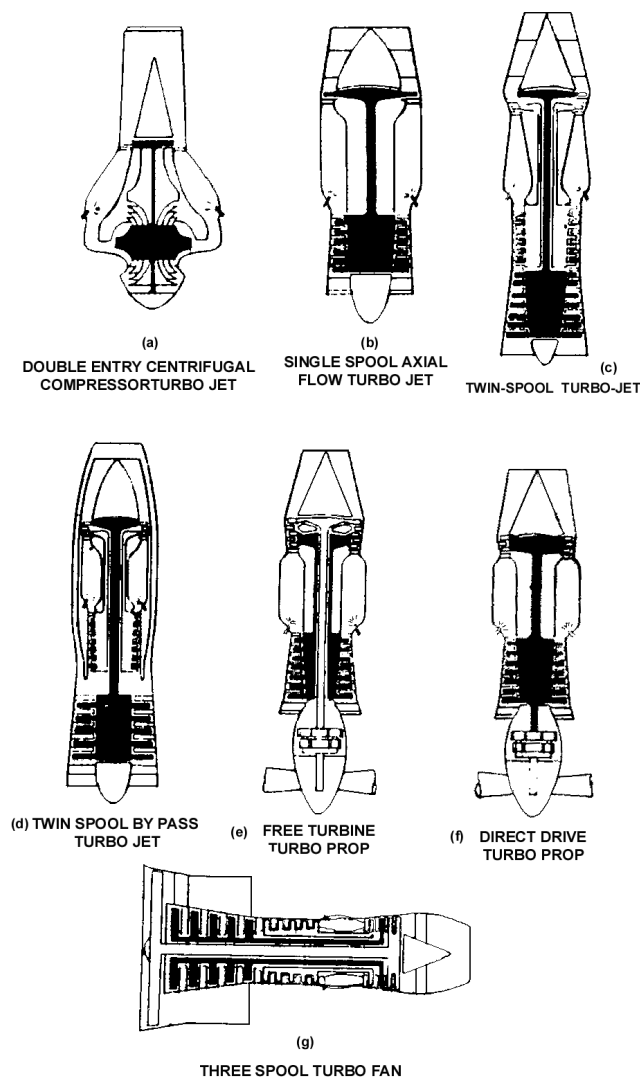

Fig. 1.3. Typical Variation In Gas Turbine Design.

is therefore essentially free from vibration. Power is produced in a continuous cycle by compressing the intake air and passing it to the combustion chamber where fuel is added and burnt to provide heat. The expansion of gases rearwards through the turbine produces the power necessary to drive, the compressor, the residual energy being used to provide jet thrust or in the case of turbo prop engines, to drive a propeller.

Propeller efficiency falls off rapidly above approximately 350 knots so that turbo prop engines are normally used to power comparatively low speed aircraft faster aircraft use turbo jet engines, by pass or turbo fan engines being favoured for high subsonic speeds because of their fuel economy and low noise level. After burning i.e. the burning

of fuel in the jet pipe to provide additional thrust, is normally used only in military aircraft due to large quantities of fuel consumed, but it may be used on civil aircraft for take off and acceleration to supersonic flight.

### LIMITATIONS

The power obtainable from the gas turbine engine is limited by the ability of the materials used in its manufacture to withstand the high centrifugal force and high gas temperature developed within engine. The life of components in the 'hot' sections of the engine, i.e. combustion chamber, turbine and jet pipes, is also influenced by the number of temperature cycles to which they are subjected. It is mainly the construction of the turbine which decides the operating speeds and temperature of the engines and although operation within these limits is often mechanically controlled, care must be taken to ensure that they are not exceeded either during ground running or in flight.

### VARIATIONS IN GAS TURBINE DESIGNS

Fig. 1.3. shows a cutway of typical engines. Fig. (a) is a cutway of typical centrifugal flow turbojets. This particular engine has a double-sided, compressor rotor, which means that air is admitted on both sides of the compressor.

Fig. (b) shows a cutway of single spool axial flow turbo jet engine single spool means that there is only one spool of compressors which is the simplest type of turbojet engine.

Fig. (c) shows a cutway of Twin spool turbo jet engine. This type of engine has been used extensively in military fighter aircraft. It has separate turbines for both compressor spools.

Fig. (d) shows a cutway of twin spool by pass turbo jet, it has one turbine for fan and one spool of compressor where as separate turbine for one spool and another turbine for another spool of compressor. Where as part of air is by-passed over second spool after being compressed in first spool. Test flight with this engine indicate a remarkable specific fuel consumption and a excellent power/weight ratios.

Fig. (e) shows a cutway of free turbine turbo prop, which has got separate turbines for the propeller and the compressor and propeller.

Fig. (f) shows a cutway of free turbine turbo prop, which has got separate turbines for the propeller and the compressor.

Fig. (g) shows a cutway of three spool turbo fan engine which has got fan stage and two compressor stages, each of them having a separate turbine.

It will be noted from a study of the foregoing illustrations that a basic difference between the centrifugal-type engine and the axial-type engine is in the airflow through the engine. The airflow through the centrifugal engine follows a rather tortuous route as compared with the airflow through the axial-flow engine. Violent changes in direction of airflow remove some of the energy from the air, and this energy is lost.

### TURBOFAN ENGINE

A turbofan engine may be considered a cross between a turbojet engine and a turboprop engine. The turboprop engine drives a conventional propeller through reduction gears to provide a speed suitable for the propeller. The propeller accelerates a large volume of air in addition to that which is being accelerated by the engine itself. The turbofan engine accelerates a smaller volume of air than the turboprop engine but a larger volume than the

The arrangement of a forward turbofan engine with a dual compressor is shown in Fig. 1.4. The fan's rotational speed on this engine is the same as the low-pressure ( $N_1$ ) compressor speed. During operation, air from the fan section of the forward blades is carried outside to the rear of streams: the cool bypass airflow and the hot turbine discharge gases which have passed through the core of the engine. The bypass air or fan air is cool because it has not passed through the actual gas-turbine engine. This fan air can account for around 80 percent of the engine's total thrust. The effect of the turbofan design is to greatly increase the power-weight ratio of the engine and to improve the thrust specific fuel consumption.

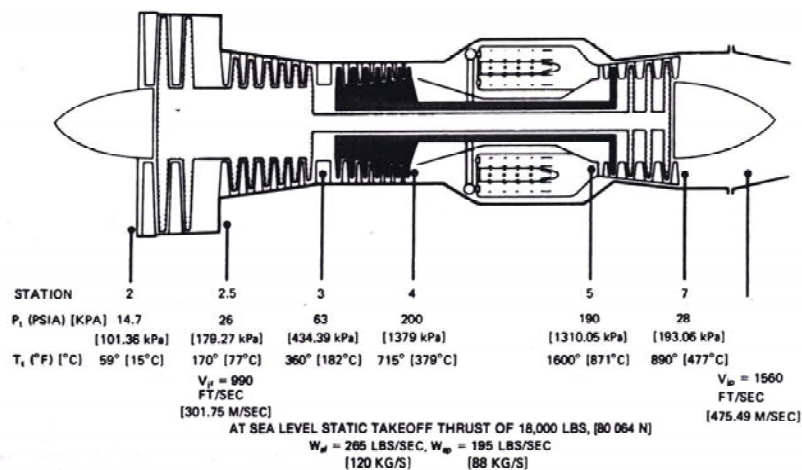

Fig. 1.4. Arrangement of a forward turbofan engine.  
(Pressure and temperature within a twin spool turbofan engine)

Turbofan engines may be high-bypass or low-bypass engines. The ratio of the amount of air that bypasses (passes around) the core of the engine to the amount of air that passes through the core is called the bypass ratio. A low-bypass engine does not bypass as much air around the core as a high-bypass engine.

Many different types of turbofan engines are in use and can be found on aircraft from small business jets to large transport-type aircraft. Most turbofan engines are constructed with a forward fan. The fan is driven by a set of core engine turbine stages designed to drive the fan only. These bypass fan blades extend into a coaxial duct which surrounds the main engine. Airflow enters the forward end of the duct and is expelled coaxially with the engine exhaust to produce additional thrust. Additional information on different types of turbofan engines is presented.

### **High-Bypass Turbofan Engine**

During recent years, the high-bypass turbofan engine has become one of the principle sources of power for large transport aircraft. Among such engines are the Pratt & Whitney JT9D, the General Electric CF6, and the Rolls Royce RB 211. These engines are used, respectively, in Boeing 747, Douglas DC-10, and Lockheed L-1011 aircraft.

A high-bypass engine utilizes the fan section of the compressor to bypass a large volume of air compared with the amount which passes through the engine. The bypass ratio for the Pratt & Whitney JT9D and the Rolls-Royce RB 211 is approximately 5:1. This means that the weight of the bypass air is five times the weight of the air passed through the core of the engine. The bypass ratio for the General Electric CF6 engine is approximately 6.2:1; however, some models have a variable bypass ratio, and the amount of bypassed air may be more or less than stated above.

The principal advantages of the high-bypass engine are greater efficiency and reduced noise. The high-bypass engine has the advantages of the turboprop engine but does not have the problems of propeller control. The design is such that the fan can rotate at its most efficient speed, depending on the speed of the aircraft and the power demanded from the engine.

On some front fan engines, the bypass airstream is ducted overboard either directly behind the fan through short ducts or at the rear of the engine through longer ducts, thus the term “ducted fan.”

Very high bypass ratios, on the order of 15:1, are achieved by using Prop-Fans, illustrated in Fig. 1.1 H and I. These are variations on the turbopropeller theme but have advanced technology propellers capable of operating with high efficiency at high aircraft speeds.

### **TURBOSHAFT ENGINE**

A turboshaft engine is a gas-turbine engine which delivers shaft horsepower through an output shaft. This engine, like the turboprop, uses almost all the exhaust energy to drive the output shaft. This type of gas-turbine engine is used in aviation mainly on helicopters and for auxiliary power units on large transport aircraft.

A gas turbine engine that delivers power through a shaft to operate something other than a propeller is referred to as a turboshaft engine. Turboshaft engines are similar to turbo prop engines. Many of the turbofan and turboprop engines previously discussed in this text are also manufactured, with minor variations, in a turboshaft version. The shaft turbine may produce some thrust, but it is primarily designed to produce shaft horsepower (shp). The turboshaft engine, with the addition of a turbine wheel or wheels to absorb the power of the escaping gases of combustion. The power takeoff may be coupled directly to the engine turbine, or the shaft may be driven by a turbine of its own (free turbine) located in the exhaust stream. Both types have been successfully used in helicopter applications; however, the free turbine is the most popular in use today. Another use of turboshaft engines is the auxiliary power unit or APU. These small gas-turbine engines are mostly used on large transport aircraft for providing auxiliary power either on the ground or in flight if needed. They are designed to provide the aircraft with electrical or pneumatic power for several on-board functions, making the aircraft more independent of ground support equipment.

### **APU Description and Location**

The APU is composed of three distinct modules: the power section, the load compressor, and the gearbox, as shown in Fig. 1.5. Air flowing into the APU can flow into the power section or the load compressor. The power section is a single-shafted gas-turbine engine which convert air and fuel into shaft horsepower. The shaft horsepower generated by the power section is used to drive the load compressor, gearbox, and accessories. The load compressor, which is driven by the power section, supplies compressed air for the airplane's pneumatic system. Inlet guide vanes regulate the amount of airflow through the compressor. The gear-box, which is also driven by the power section, contains gears and drive pads for the various APU accessories, including the APU generator.

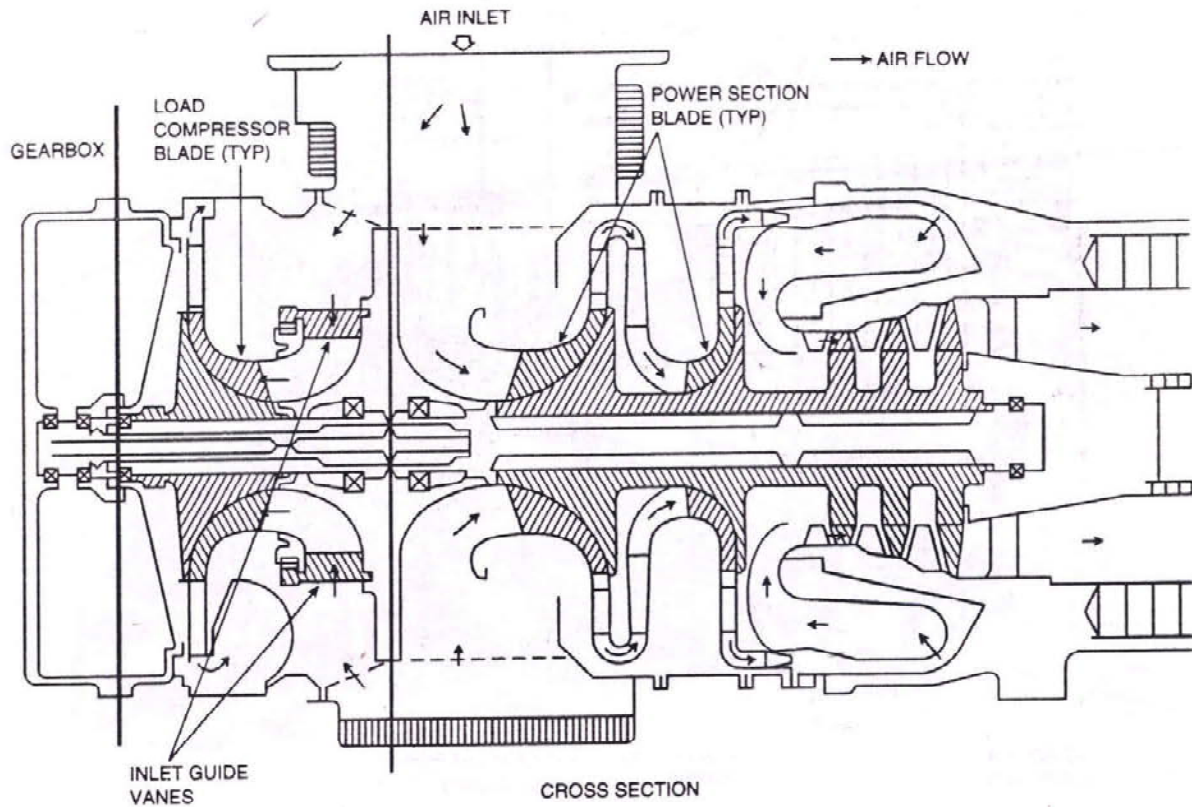

Fig. 1.5. Diagram of auxiliary power unit engine airflow

The APU is located in the aft portion of the fuselage (tail cone area). It is suspended in its compartment from the APU air inlet plenum. Access into the APU compartment is through the APU access doors, which are shown in Fig.1.6

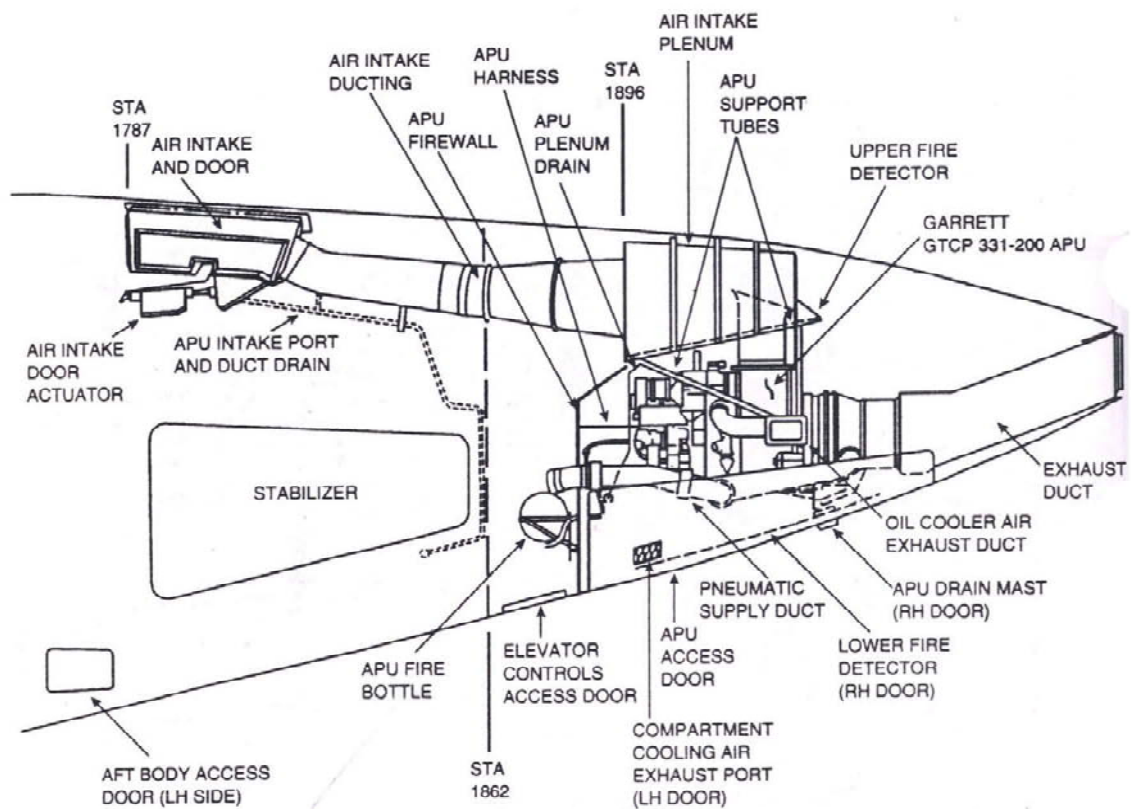

Fig.1.6. Boeing 757 auxiliary power unit installation

### The Bell Model 204B Power Train

The power-train system is comprised of a transmission freewheeling drive unit, engine-to-rotor drive shafts, five tail-rotor drive shaft segments with bearing hanger assemblies, and the tail-rotor gearbox.

A portion of the power train for the Bell Model 204B helicopter is shown in Fig. 1.7. This figure shows how the main transmission is installed at the front of the turboshaft engine. In the drive coupling between the engine and the transmission is a freewheeling (sprag) clutch, which allows the rotor systems to continue to operate even if the engine stops, permitting autorotational descent in includes two planetary systems which have a total gear ratio of 20.37:1; that is, the engine drive shaft turns more than 20 times as fast as the main rotor.

The gear reduction to the tail rotor, including the tailrotor transmission gearing, provides a gear reduction of 4:1. The tail-rotor drive extends to the rear from the accessory drive and sump case, which is below the main transmission.

### Turboprop Engine

A turboprop engine, is nothing more than a gas turbine or turbojet with a reduction gearbox mounted in the front or forward end to drive a standard airplane propeller. This engine uses almost all the exhaust-gas energy to drive the propeller and therefore provides very little thrust through the ejection of exhaust gases. The exhaust gases represent only about 10 percent of the total amount of energy available. The other 90 percent of the energy is extracted by the turbines that drive the compressor and a second turbine that drives the propeller. The basic components of the turboprop engine are identical to those of the turbojet- that is, compressor, combustor, and turbine. The only difference is the addition of the gear-reduction box to reduce the rotational speed to a value suitable for propeller use.

The gas-turbine engine in combination with a reduction-gear assembly and a propeller has been in use for many years and has proved to be a most efficient power source for aircraft operating at speeds of 300 to 450mph [482.70 to 724.05 km/h]. These engines provide the best specific fuel consumption of any gas-turbine engine, and they perform well from sea level to comparatively high altitudes over 20,000 ft [6096 m]).

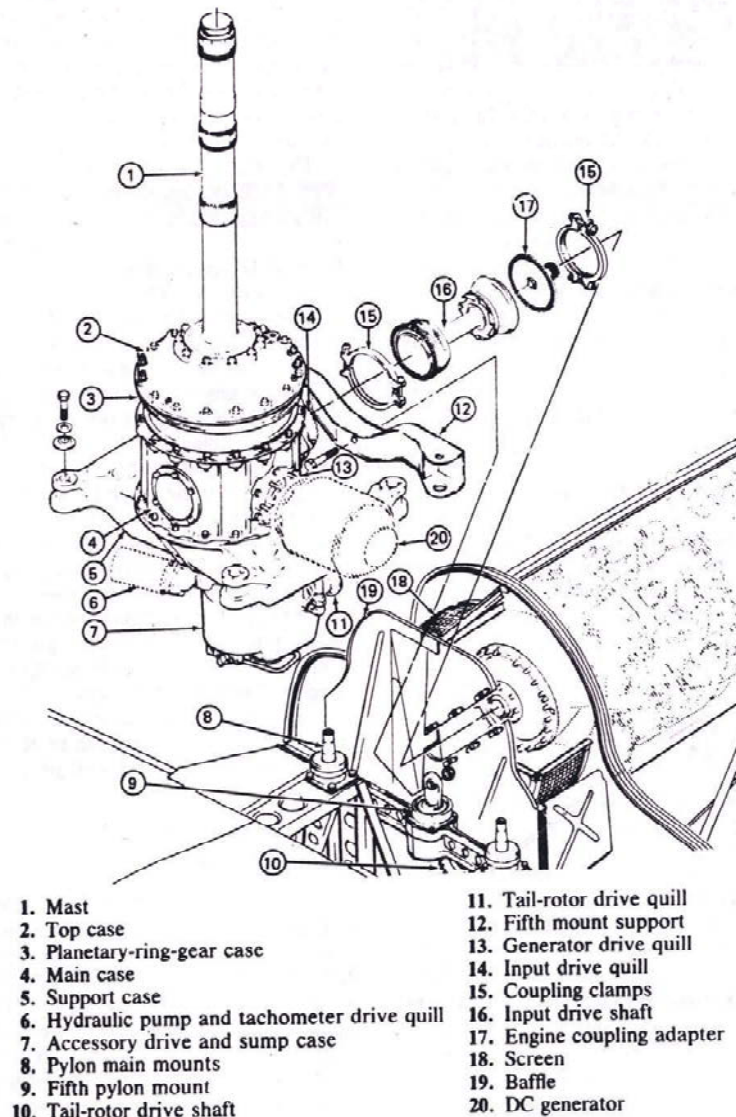

Fig. 1.7. Main transmission and drive shafts for the Bell Model 204B helicopter.

Although various names have been applied to gas-turbine engine/propeller combinations, the most widely used name is turboprop, which will generally be used in this section. Another popular name is "propjet."

The power section of a turboprop engine is similar to that of a turbojet engine; however, there are some important differences, the most important of which is found in the turbine section. In the turbojet engine, the turbine section is designed to extract only enough energy from the hot gases to drive the compressor and accessories. The turboprop engine, on the other hand, has a turbine section which extracts as much as 75 to 85 percent of the total power output to drive the propeller. For example, the Allison Model 501 engine extracts 3460 hp [2580.12 kW] for the propeller and produces 726 lb [3229.25 N]. This means that the turbine section of the turboprop usually has more stages than the turbine section of the turbojet engine and the turbines extract more energy from the hot gas stream of the exhaust. In a turboprop engine, the compressor, the combustion section, and the compressor turbine comprise what is often called the gas generator or gas producer. The gas generator produces the high-velocity gases which drive the power turbine. The gas generator section performs only one function: converting fuel energy into high-speed rotational energy.

In the turboprop engine, the primary effort is directed toward driving the propeller. One method of doing this is to use what is referred to as a free turbine. A free turbine is not mechanically connected to the gas generator; instead, an additional turbine wheel is placed in the exhaust stream from the gas generator. The extra turbine wheel, referred to as the power turbine, is shown in Fig. 1.8.

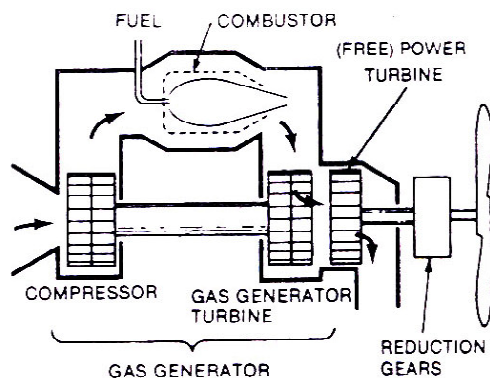

Fig. 1.8. Free-turbine-type power conversion

A different method of converting the high-speed rotational energy from the gas generator into usable shaft horse power is illustrated in Fig. 1.9. In this case, the gas generator (shown at right in the illustration has an additional (third) turbine wheel. This additional turbine capability utilizes the excess hot gas energy (that is, energy in excess of that required to drive the engine's compressor section) to drive the propeller. In a fixed shaft engine, the shaft is mechanically connected to the gearbox so that the high-speed low-torque rotational energy transmitted into the gearbox from the turbine can then be converted to the low-speed high-torque power required to drive the propeller.

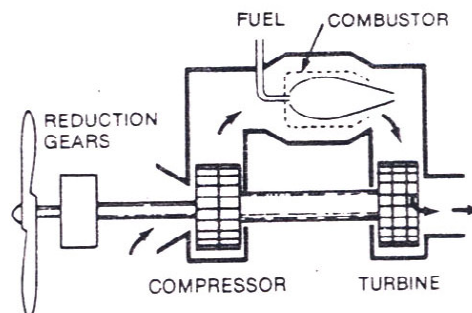

Fig. 1.9. Fixed-shaft-type power conversion.

The gear reduction from the engine to the propeller is of a much higher ratio than that used for reciprocating engines because of the high rpm of the gas-turbine engine. For example, the gear reduction for the Rolls-Royce Dart engine is 10.75:1, and the gear reduction for the Allison Model 501 engine is 13.54:1.

Because the propeller must be driven by the turboprop engine, a rather complex propeller control system is necessary to adjust the propeller pitch for the power requirements of the engine. At normal operating conditions, both the propeller speed and engine speed are constant. The propeller pitch and the fuel flow must then be coordinated in order to maintain the constant-speed condition- that is, when fuel flow is decreased, propeller pitch must also decrease.

## LARGE TURBOPROP ENGINES

### The Rolls-Royce Dart Turboprop Engine

**General Description.** The Rolls-Royce Dart turboprop engine has been in use for many years on a variety of aircraft, including the Vickers Viscount and the Fairchild F-27 Friendship. This engine has proven to be rugged, dependable and economical, with overhaul periods extending to more than 2000h.

The Dart engine utilizes a single-entry two-stage centrifugal compressor, a can-type through-flow combustion section, and a three-stage turbine. The general design of the engine is illustrated in Fig. 1.10. This drawing shows the arrangement of the propeller, reduction gear, air inlet, compressor impellers, combustion chambers, turbine, and exhaust. The engine is approximately 45 in [114.3 cm] in diameter and 98 in [248.92cm] in length.

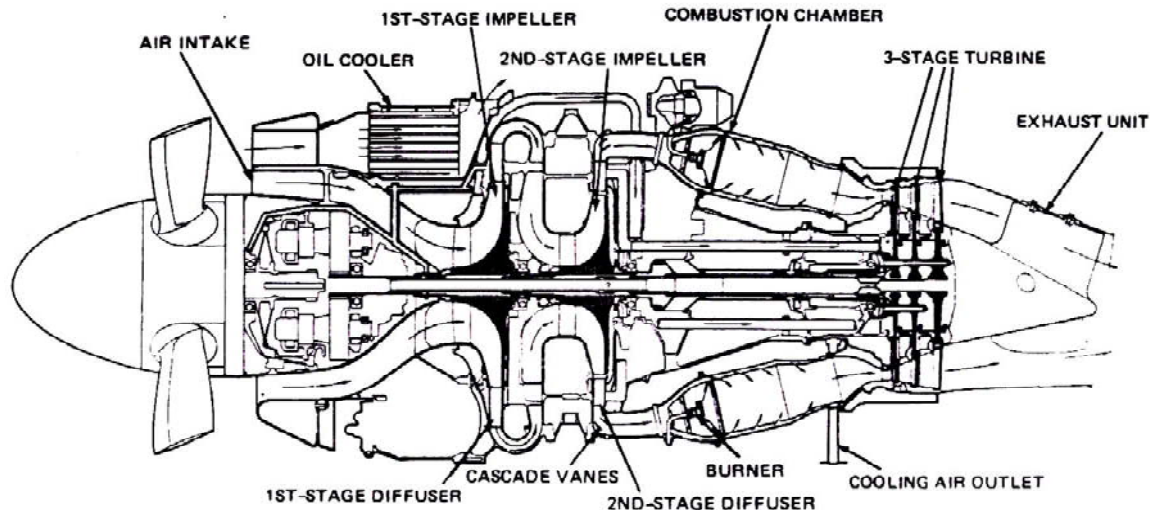

Fig. 1.10. Arrangement of the Rolls-Royce Dart engine

### Engine Data

The general and performance data for the Dart Model 528 engine are as follows:

|                                |                         |                        |
|--------------------------------|-------------------------|------------------------|
| Power output                   | 1825 shp plus<br>485 lb | 1368 kW plus<br>2157 N |
| Compression ratio              | 5.62:1                  |                        |
| Engine rpm                     | 15,000                  |                        |
| Weight without propeller)      | 1415 lb                 | 642 kg                 |
| SFC (special fuel consumption) | 0.57 lb/eshp/h          | 346.72 g/kW/h          |
| Power-weight ratio             | 1.51 eshp/b             | 2.13 kW/kg             |

### Internal Features

The cutaway photograph of the Dart engine reveals the internal construction of the engine. At the forward end is the reduction-gear assembly, which reduces the propeller-shaft speed to 0.093 of the speed of the engine. The reduction gear housing is integral with the air-intake casing.

Immediately to the rear of the reduction-gear assembly is the compressor section, which includes two centrifugal impellers. Both impellers are clearly visible in the illustration. Accessory drives are taken from the reduction-gear assembly and through a train of gears aft of the second-stage compressor impeller.

Seven interconnected combustion chambers are located between the compressor section and the turbine. These combustion chambers are skewed, or arranged in a spiral configuration, to shorten the engine and take advantage of the direction of airflow as it leaves the compressor.

A three-stage turbine is located to the rear of the combustion chambers. As in other turboprop engines, this turbine is designed to extract as much energy as possible from the high-velocity exhaust gases.

### Reduction-Gear Assembly

The reduction-gear assembly, shown in Fig. 1.11, is of the compound type having high-speed and low-speed gear trains. The high-speed gear train consists of a high-speed pinion connected to the main shaft that drives three layshafts through helical gear teeth. To isolate the main shaft couplings from propeller vibrations, a torsionally flexible shaft is used to couple the high-speed pinion to the main shaft. The three layshafts are mounted in roller bearings supported by panels in the gear casing.

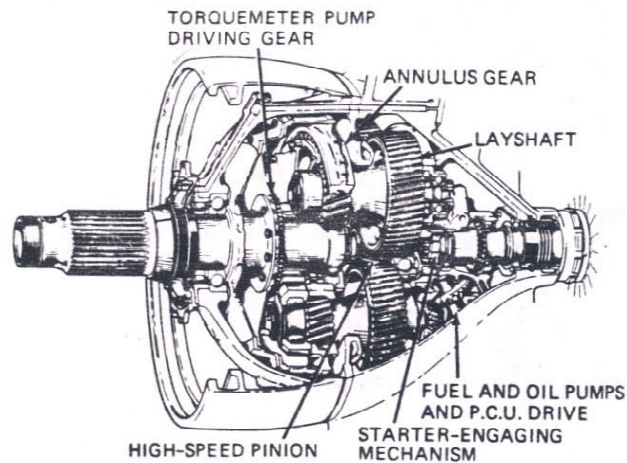

Fig. 1.11. Reduction-gear assembly for the Dart engine

The low-speed gear train consists of helical gears, formed on the front ends of the layshafts, which drive the internal, helically toothed annulus gear. This annulus gear is bolted to the propeller-shaft driving disk. As a result of driving through the helical gears, the layshafts tend to move axially. This movement is limited by limit shafts mounted coaxially within the layshafts. Each limit shaft is prevented from moving by a ball thrust race at the rear.

The propeller shaft is supported by roller bearings housed in the front panel and the domed front casing. Axial thrust is taken on a ball bearing mounted behind the front roller bearing. A labyrinth-type seal assembly, pressurized by compressed air, surrounds the propeller shaft where it passes through the front cover and prevents loss of lubrication oil to the atmosphere.

To permit propeller oil to be transferred from the stationary casing to the rotating propeller shaft, a transfer seal assembly is used. It consists of babbitt lined with bronze bushing fitting closely around an adapter located inside the rear end of the propeller shaft. Tubes screwed into the adapter convey the oil to the pitch-control mechanism.

### Torquemeter

Under normal operating conditions, the helical teeth of the gear train produce a forward thrust in each layshaft which is proportional to the propeller-shaft torque. This load is hydraulically balanced by oil pressure acting on a piston assembly incorporated in the forward end of each layshaft. The necessary oil pressure is obtained by boosting engine oil pressure with a gear pump mounted on the layshaft front-bearing housing and driven from a gear attached to the propeller shaft.

The forward thrust of the layshafts resulting from the greater torque of the low-speed gear train is partially balanced by the rearward thrust produced by the lesser torque of the high-speed gear train. The residual forward thrust is balanced by the torquemeter oil pressure. A gage in the cockpit indicates this pressure, which is a measure of the torque transmitted by the gear. The engine power is calculated from the reading of the gauge.

### Auxiliary Drives

The auxiliary drives receive power from a bevel gear, splined to the rear of the lower limit shaft, which meshes with another bevel gear, splined to the rear of the lower limit shaft, which meshes with another bevel gear supported in plain bearings in the rear panel of the reduction-gear case. Through the auxiliary drives, the oil pumps, fuel pumps, and propeller control unit are driven.

## DIFFERENCES BETWEEN VARIOUS TYPES OF ENGINES

### FORWARD FAN

1. Fan is fitted in an inlet fan section in front of the compressor.
2. Tip efficiency by low pressure compressor turning.
3. Cool air is drawn in from the front of combustion chamber.
4. Forms conventional inlet duct.
5. Fan is driven by the turbine through a shaft passing inside the engine.
6. More than two fans for better acceleration.

### AFT FAN

1. Fitted in the exhaust section aft the main turbine at the rear of the engine (periphery of last turbine).
2. Exhaust tip efficiency by better final velocity.
3. Cool air drawn in after the combustion chamber.
4. Efficient exhaust duct.
5. Fan extended to the free turbine where entering gases pass through.
6. Generally one turbine with blade



7. Fan air speeds out foreign matter
8. Front of the engine has a large diameter for casing and simple construction.

7. No provision to avoid foreign matter.
8. Rear of the engine has large diameter for casing and complicated construction.

#### DIFFERENCE BETWEEN TURBOJET AND TURBO PROP

##### TURBOJET

1. No propeller in front .
2. Thrust is due to the engine pressure variation and final velocity.
3. Simple air intake.
4. More noise to single or two turbine.
5. Less air handled.
6. More weight.
7. No reduction gear. drives compressor direct drive.
9. Efficient at high altitude.
10. Ice formation at inlet position at high altitude.

##### TURBOPROP

1. Propeller in front.
2. Thrust is due to the displacement of air.
3. Complicated air intake.
4. Less noise due to large diameter turbine.
5. More air handled.
6. Less weight.
7. Has reduction gear. 8. Turbine
8. Turbine drives propeller through, splined shaft.
9. Efficient at low altitude.
10. No ice formation, aircraft flies at low altitude.

#### DIFFERENCE BETWEEN TURBOPROP AND TURBO SHAFT

##### TURBO PROP

1. Prop is fitted in front of the turbine section.
2. Prop shaft is separated from connecting torque shaft.
3. Drives propeller in same engine axis or off set.
4. Is driven through spur or bevel planetary gear.
5. Propeller throws the air towards the rear.
6. Speed of prop is more.

##### TURBO SHAFT

1. Shaft is fitted at the rear of the turbine section.
2. Shaft is bolted to the turbine.
3. Drives the rotor shaft 90° to the engine axis.
4. The turbine speed is reduced through having bevel planetary.
5. Rotor throws air towards top, bottom or at angle.
6. Speed of rotor shaft is less

#### CONSTRUCTIONAL DETAILS OF GASTURBINE

##### MAJOR COMPONENTS OF GASTURBINE ENGINES

In many types of turbine engines, it is not possible to list all the major components and have the list apply to all engines. There are several components and common to most turbine engines, however, and a knowledge of these will be helpful in developing a further understanding of aviation gas-turbine engines.

The operation of any gas-turbine engine requires that provision be made for three principal functions:

- i. The compression of air
- ii. The expansion of the air by burning fuel and
- iii. The extraction of power from the jet stream of the engine for driving the compressor and accessories. Thus, we may say that gas-turbine engine comprises three main sections the compressor section, the combustion section and the turbine section.

In addition to these three main section, there are also component which serve to provide transition from one main functional section to another. The following is a list of all the major components, arranged as they would appear from the front of the turbine to the rear.

- i. Inlet duct and guide vanes.
- ii. The compressor.
- iii. The diffuser, with or without air adaptor.
- iv. The combustion chamber.
- v. The nozzle diaphragm.
- vi. The turbine.
- vii. The exhaust cone.
- viii. The after burners (if the engine is so equipped).
- ix. The accessory section (which may be located at the front of the engine or further to the rear).

**The Inlet Duct And Guide Vanes**

Turbine engine inlet duct must furnish a relatively distortion free and high energy supply of air on the required quantity to the compressor, the uniform and steady air flow is necessary to avoid compressor stall and excessively high engine temperature at the turbines. The high energy enables the engine to produce an optimum amount of thrust. The air inlet duct is considered to be an air frame part. Inlet ducts has following functions.

- (i) It must be able to recover, as much air as possible and deliver this pressure to the front of the engine with minimum pressure loss.
- (ii) The duct must uniformly deliver air to compressor inlet with as little turbulence and pressure variations as possible.

There are two basic types of duct

- (i) Single entry (ii) Divided entry.

**Single Entry**

This is the simplest and most effective because of the duct inlet is located directly ahead of the engine and the aircraft is in such a position that it scoops the undisturbed air. The duct can be built strong and straight with relatively gentle curvatures. In single engine aircraft installation the duct is necessarily is relatively curved and hence some pressure drop is possible by the long duct, but the condition is offset by smooth air flow characteristic, although a short inlet duct results in minimum pressure drop, the engine often suffer from inner turbulence specially at low air speed and high angle of attack.

**Divided Entry Duct**

The requirements of high speed single engine aircraft in which pilot seat is low in the fuselage and close to the nose render it a difficulty to employ a single entrance duct. Some types of divided duct which takes air from either side of the fuselage may be required. The divided ducts can be following types (i) Scoop (ii) Flush (iii) Wing root entrances.

**Variable Geometry Duct**

A super sonic inlet duct progressively decreases in area in the down streams, again it will follow the general configuration until the velocity of the incoming air is reduced to match 1 and below. The aft section of the duct will then commence to increase in area since this part must act as a subsonic diffuser.

For very high speed aircraft, the inside area or configuration of duct will be changed by a mechanical device as the speed of the aircraft increases or decreases. The duct of this type is usually known as variable geometry inlet duct.

Two main methods used to diffuse the inlet air and reduce the inlet air velocity, at supersonic flight speed, one method is to vary the area of geometry of inlet duct either by using a movable restriction such as wedge inside the duct, another method is some short of variable air flow by pass arrangement which extracts part of inlet air flow from the duct ahead of the engine. Another method is by using a shock wave in the air stream, a shock wave is a thin region of discontinuity in a flow of air or gas during which velocity, density temperature of gas undergo a sudden change.

A shock wave is set up in a supersonic flow of air entering the duct by means of some restriction which automatically protrudes into the duct in high flight machine. The shock waves results in diffusion of this airflow which reduces the velocity of air. In some cases both shock waves method and variable geometry method of casing diffusion are used in combination.

**Bell Mouth Air Inlet**

Bell mouth air inlet are convergent in shape and are used

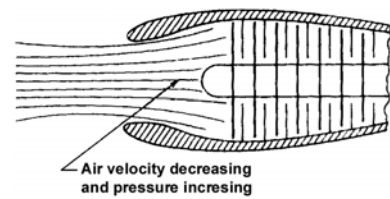

Normal airflow

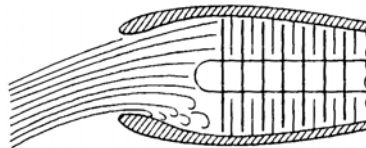

Distorted flow

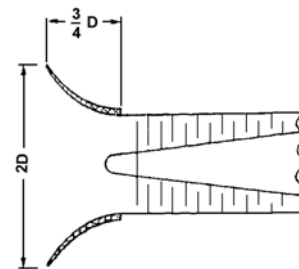
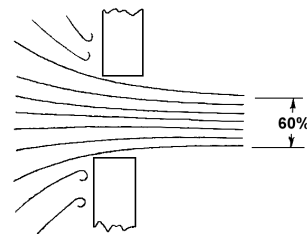

Bellmouth inlet

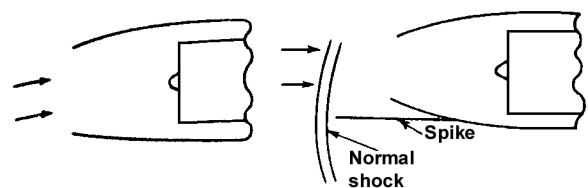

Subsonic duct

Transonic duct

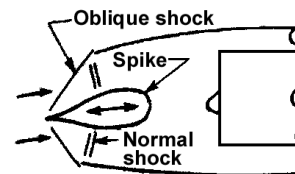

Supersonic duct with variable geometry operating at design speed

Fig. 1.12. Various types of air inlets.

on helicopter and slow moving aircraft which flies below ram recovery speed. This type of inlet reduces a large brake factor but drag is outweighed by high degree of Aerodynamic efficiency.

Engines being calibrated on ground run test, also utilizes bell mouth anti ingestion screen. Duct loss is slight in this design that it is considered to be zero. Engine performance data such as engine trimming while using a bell mouth engine inlet, aerodynamic efficiency and duct loss are shown in fig.3. It can be seen that rounded L.E. allows air stream to make use of total inlet cross section where as effective diameter of sharp edge orifice is greatly reduced.

### **Air Inlet Vortex Destroyer**

When the jet engine operating on ground, the engine air inlet vortex can some times be formed between the air inlet and ground. This vortex can cause strong suction force capable of lifting foreign objects from the ground into the engine causing serious damage. To minimize the ingestion of debris, an inlet vortex destroyer is used. This destroyer is nothing but a small jet stream directed downwards from the lower L.E. of the nose cowl to the ground to destroy the vortex base. Bleed air from the engine is used as the vortex destroying stream, it is controlled by a valve located in the nose cowl. The control valve is a two position valve which is opened by a L/G weight switch. The valve closes when the aircraft leaves the ground and weight of aircraft is removed from the L/G. The valve opens when touches ground and when weight switch contact is made.

### **Foreign Object Damage**

One of the major problems encountered in the operation of axial flow engines is foreign object damage. Rocks drawn into the air inlet during taxiing cause considerable damage because they nick or scratch the compressor and turbine blades as they pass through the engines, which can lead to fatigue failure with the result that the engine may throw a blade in flight. This could result in loss of the aircraft or serious damage to the engine.

To prevent foreign object damage, the air inlet on the engine are screened. These screens are effective in removing large objects from the air stream, but they will not prevent small rocks from entering the engine. Small rocks, sand and grass can do a great amount of damage to the engine.

### **Air Inlet Icing**

The air screen at the inlet of an axial flow engine is subject to icing, with the result that the engine may stop. The engine nose cowl, nose dome and inlet guide vanes are subject to icing, however, and it is necessary to incorporate provisions in the engine nose cowlings to prevent the formation of ice. Jet engine anti icing system normally make use of a high temperature air from the diffuser section.

## **COMPRESSORS**

In the gas turbine engine, compressor of the air before expansion through the turbine is effected by one of two basic types of compressor, one giving a centrifugal flow and the other an axial flow. Both types are driven by the engine turbine and are usually coupled direct to the turbine shaft.

The centrifugal flow compressor is a single or two stage unit employing an impeller to accelerate the air and a diffuser to produce the required pressure rise. The axial flow compressor is a multi stage unit employing alternate rows of rotating (rotor) blades and stationary (stator) blades to accelerate and diffuse the air until the required pressure rise is obtained.

With regards to the advantages and disadvantages of two types, the centrifugal compressor is usually more robust than the axial compressor and is also easier to develop and manufacture. The axial compressor, however, compresses more than a centrifugal compressor of the same frontal area and can also be designed for high pressure ratios much more easily. Since the air flow is an important factor in determining the amount of thrust, this means that the axial compressor engine will also give more thrust for the same frontal area.

### **The Centrifugal Flow Compressor**

Have a single or double sided impeller and occasionally a two-stage, single sided impeller is used as on the Roll's Royce Dart. The impeller is supported in a casing that also contains a ring of diffuser blades. If a double entry impeller is used, the airflow to the rear side is reversed in direction and a plenum chamber is required.

### **Principles Of Operation**

The impeller is rotated at high speed by the turbine and air is continuously induced into the centre of the impeller. Centrifugal action causes it to flow radially outwards along the vanes to the impeller tip, thus accelerating the air and also causing a slight rise in pressure to occur. The engine intake duct may contain vanes that provides an initial whirl to the air entering the compressor.

The air on having the impeller, passes into the diffuser section where it passages from the divergent nozzles and converts most of the kinetic energy into pressure energy. In practice, it is usual to design the compressor so that about half of the pressure rise occurs in the impeller and half in the diffuser.

The air mass flow through the compressor and the pressure rise depend on the rotational speed of the impeller, therefore impellers are designed to operate at tip speed of up to 1600 ft per second. By operating at such high tip speeds, the air velocity from the impeller is increased. So that greater energy is available for conversion to pressure. Another factor influencing the pressure rise is the inlet air temperature, for the lower temperature of air entering the impeller the greater the pressure, the pressure rise for a given amount of work put into the air by the compressor, is a measure of the increase in the total heat of the air passing through the compressor.

To maintain the efficiency of the compressor, it is necessary to prevent excessive air leakage between the impeller and the casing, this is achieved by keeping their clearances as small as possible.

### Construction

The construction of the compressor centres around the impeller diffuser and air intake systems. The impeller shaft rotates in ball and roller bearings and is either common to the turbine shaft or split in the centre and connected by a coupling, which is usually designed for ease of detachments.

### Impellers

The impeller consists of a forged disc with integral, radially disposed vanes on one or both sides forming divergent

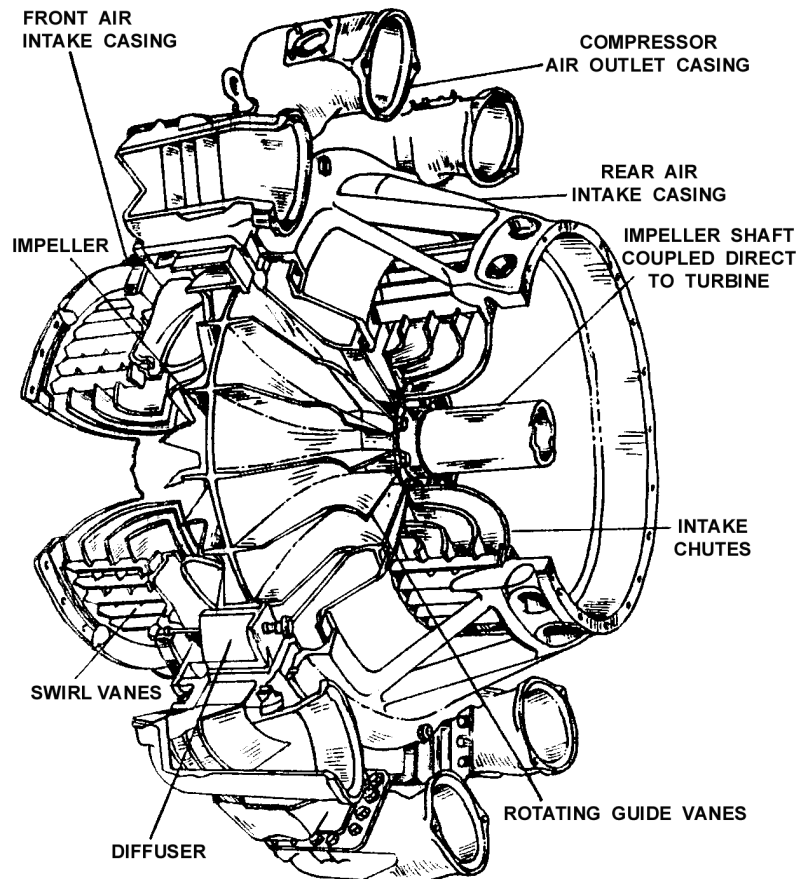

Fig. 1.13. A typical centrifugal flow compressor.

passages. The vanes may be swept back but for ease of manufacture straight radial vanes are usually employed. To ease the change of air flow from the axial to the radial direction, the vanes in the centre of the impeller are curved in the direction of rotation. The curved sections may be integral with the radial vanes, or formed separately for easier and more accurate manufacture.

The choice of impeller is determined by the engine design requirements, but it is claimed that the single entry ducting allows the air to be fed into the compressor at the best all round efficiency. It is also claimed that the single entry ducting minimizes the chances of surging at altitude, because it makes more efficient use of the ram effect than, does the double entry ducting. A small amount of heating also occurs on the double entry ducting.

### Diffusers

The diffuser assembly may be an integral part of the compressor casing or a separately attached assembly. In each instance it consists of a number of vanes formed tangential to the impeller. The vane passages are divergent to convert the kinetic energy into pressure energy and inner edges of the vanes are in line with the direction of the resultant airflow from the impeller. The clearance between the impeller and the diffuser is an important factor, as too small a clearance will set up aerodynamic impulses that could be transferred to the impeller and create an unsteady airflow and vibration.

### Axial Flow Compressor

An axial flow compressor consists of one or more rotor assemblies that carry blades of aerofoil section and are mounted between bearings in the casings in which are located the stator blades. The compressor is a multi stage unit as the amount of work done (pressure increase) in each stage is small, a stage consists of a row of rotating blades followed by a row of stator blades. Some compressors have an additional row of stator blades, known as intake or inlet guide vanes, to

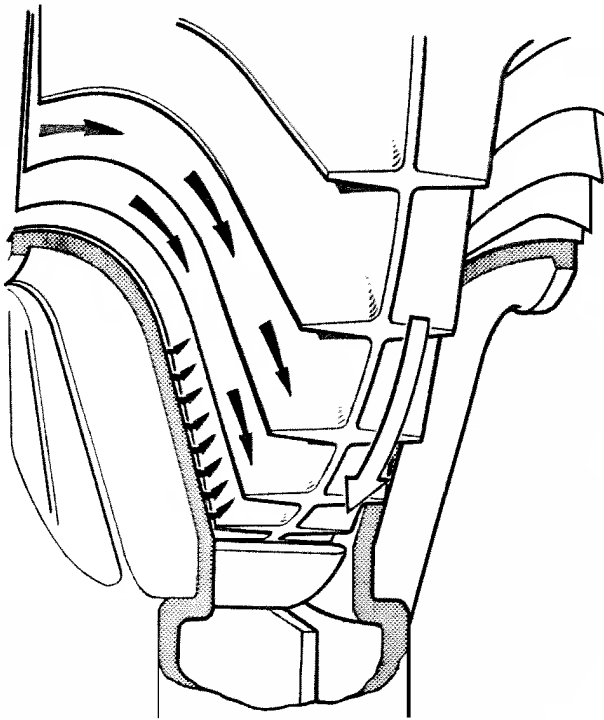

Fig. 1.14. Impeller working clearance and air leakage.



Fig. 1.15. Typical impeller for centrifugal compressor.

guide the air on to the first row of rotor blades. The angular setting of the vanes can be automatically controlled to suit the airflow requirements at various operating conditions.

From the front to the rear of the compressor, i.e. from the low to high pressure end, there is gradual reduction of the air annulus area between the rotor shaft and the stator casing. This is necessary to maintain the axial velocity of the air constant as the density increases through the length of the compressor. The convergence of the air annulus is achieved by the tapering of the casing or rotor. A combination of both is also possible, with arrangement being influenced by manufacturing problems and other mechanical design factors.

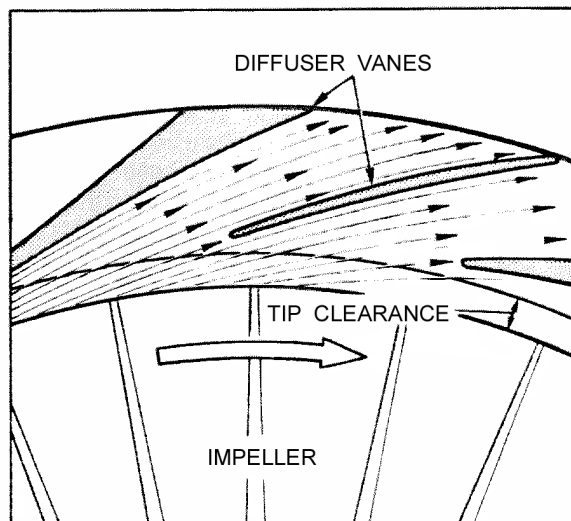

Fig. 1.16. Airflow at entry to diffuser.

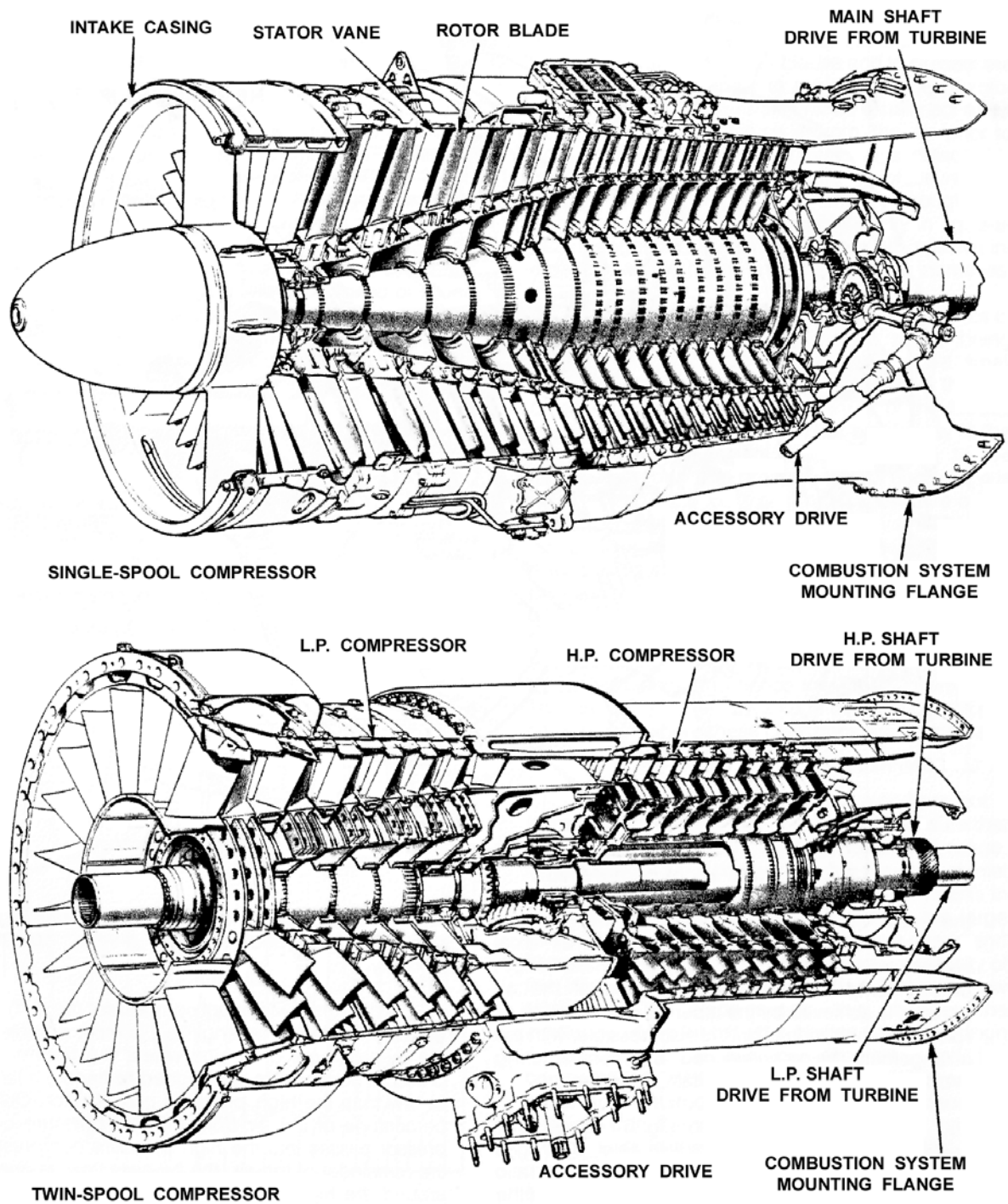

Fig. 1.17. Typical Axial Flow Compressors.

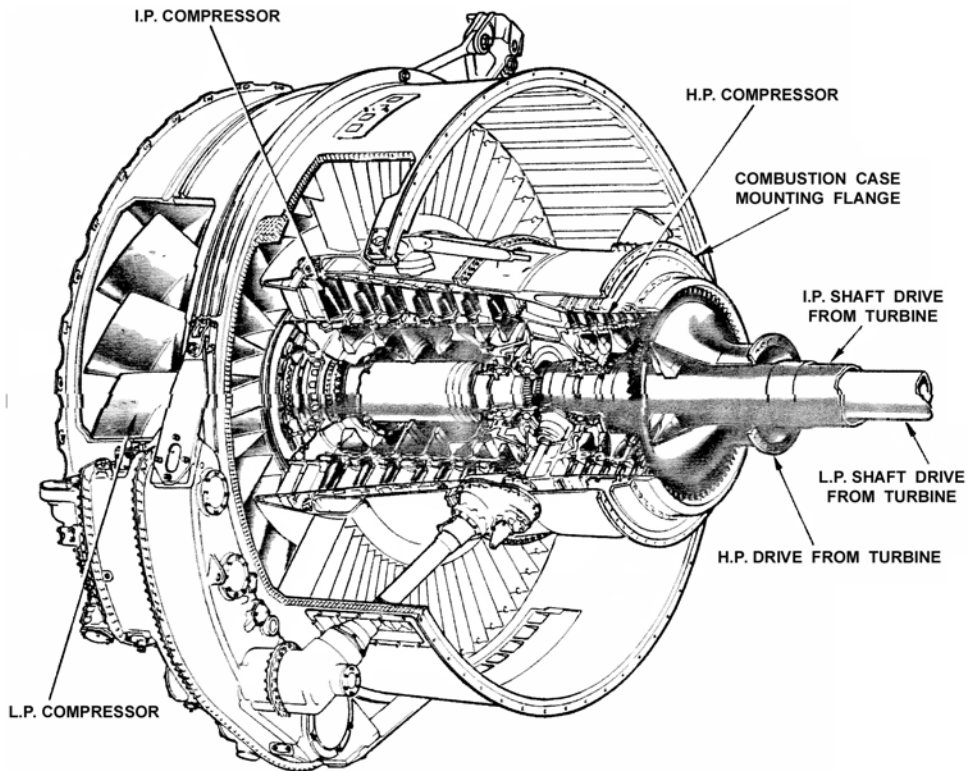

Fig. 1.18. Typical Triple Spool Compressor.

A single spool compressor consists of one rotor assembly and stators with as many stages as necessary to achieve the designed pressure ratio, and all the airflow from the intake passes through the compressor. The multi spool compressor consists of two or more rotor assemblies, each driven by their own turbine at an optimum speed to achieve higher pressure ratio and to give greater operating flexibility.

Although a twin spool compressor can be used for a pure jet engine, it is most suitable for the by pass type of engine where the front or low pressure compressor is designed to handle a larger mass airflow than the high pressure compressor. Only a percentage of the air from the low pressure compressor passes into a high pressure compressor, the remainder of the air, the by pass flow is ducted around the high pressure compressor. Both flows mix in the exhaust system before passing to the propelling nozzle.

A fan may be fitted to the front of a single or twin spool compressor and on these types of engines the fan is driven at the same speed as the compressor to which it is fitted. On engines of the triple spool type, the fan is in fact the low pressure compressor and is driven by its own turbine separately from the intermediate pressure compressor and the high pressure compressor. The low pressure compressor has large rotor (fan) blades and stator blades is designed to handle a far larger mass airflow and the other two compressor, each of which has several stages of rotor blades. A large proportion of air from the lower part of the fan and known as the cold stream, by passes the other two compressors and is ducted to atmosphere through the cold stream nozzle. The smaller airflow, from the inner part of the fan and known as hot stream passes through the intermediate and high pressure compressor when it is further compressed before passing into the combustion system.

### Principles Of Operation

During operation, the rotor is turned at high speed by the turbine, so that air is continuously induced into the compressor, where it is accelerated by the rotating blades and swept rearwards on the adjacent row of stator blades. The pressure rise in the airflow results from the diffusion process in the rotor blade passages and from a similar process in the stator blade passages; the latter also serves to correct the deflection given to the air by the rotor blades and to present the air at the correct angle to the next stage of rotor blades. The last row of stator blades usually act as "air straightener" to remove the whirl from the air so that it enters the combustion system at a fairly uniform axial velocity. The changes in pressure and velocity that occur in the airflow through the compressor are shown in fig. 1.18. These changes are accompanied by a progressive increase in air temperature as density increases.

Across each stage, the ratio of the total pressures of the out going air and inlet air is quite small, being between 1:1 and 1:2. The reason for the small pressure increase through each stage is that the rate of diffusion and the deflection angles of the blades must be limited if losses due to air break away at the blades, and subsequent blade stall are to be avoided. The small pressure rise through each stage together with the smooth flow path of the air, does much to contribute to high efficiency of the axial flow compressor. For instance, the maximum air velocity through the axial compressor corresponds to a Mach number of about 0.9 and the flow is almost of thorough. On the other hand, the

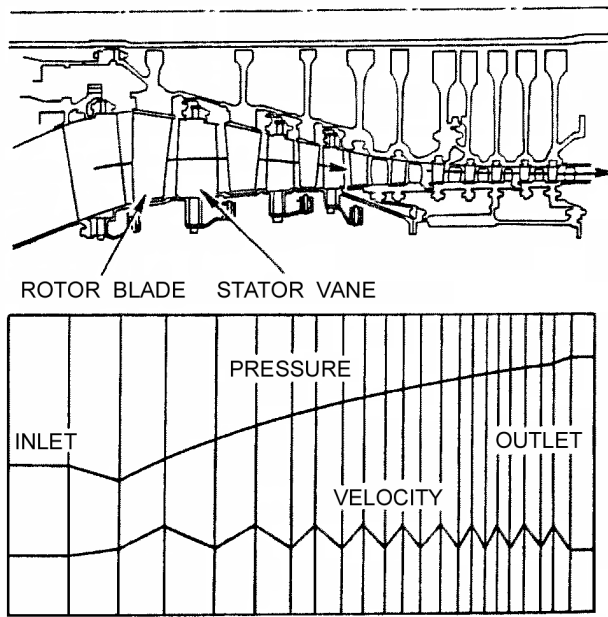

Fig. 1.19. Pressure and velocity changes through an axial compressor.

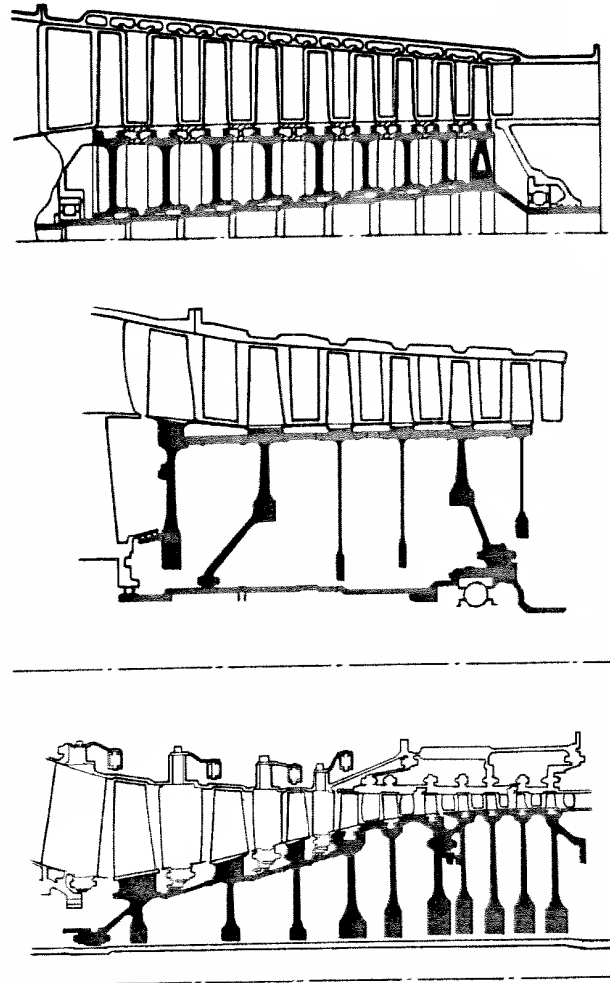

Fig. 1.20. Rotors of drum and disc construction.

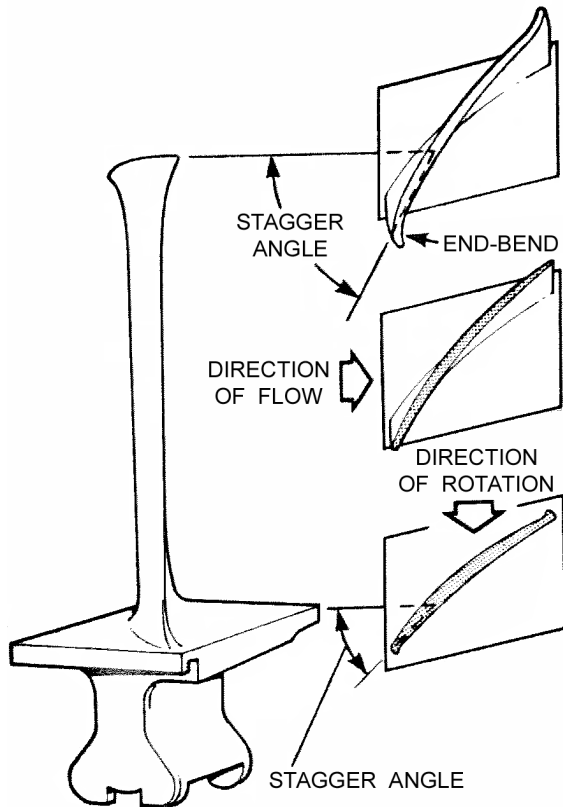

Fig. 1.21. A typical rotor blade showing twisted contour.

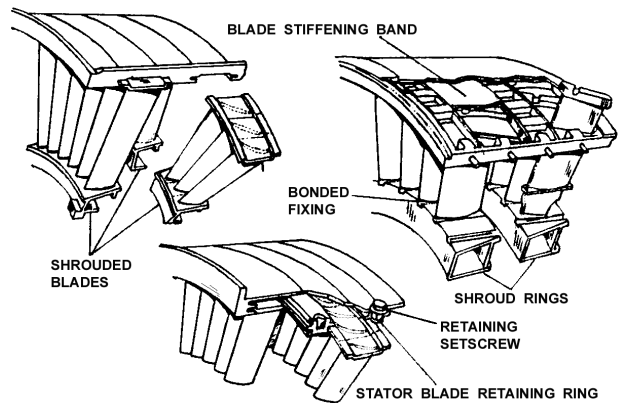

Fig. 1.22. Methods of securing blades to compressor casing.



velocity through a centrifugal compressor is super sonic in places, reaching a Mach number of 1.2; the flow in this instance is tortuous culminating in a right angle bend at the outlet to the combustion chamber.

Because an axial flow compressor requires a large number of stages to produce a high compressor ratio, as the number of stages increases it becomes more difficult to ensure that each stage will operate efficiently over an engine speed range. An automatic system of airflow control is sometimes necessary to maintain compressor efficiency, but a more flexibly operated engine can be achieved by having more than one compressor with each compressor being an independent system, driven by separate turbine assemblies through coaxial shafts. The compressor, therefore, should be designed to operate more efficiently and with greater flexibility over a wide speed range.

A by pass engine invariably has a spool compressor with the low pressure compressor supplying sufficient air for both the by pass system and the high pressure compressor. Still greater flexibility can be obtained and higher maximum compression ratios reached by using an automatic airflow control system for high pressure compressor, this method is used on the Rolls Royce spool series of engines. Although an engine may have a front or an aft fan, the front fan is favoured by most manufacturers as giving greater reliability, due to the fan operating in the cold section of the engine. The fan can have one or more stages of large blades, both rotor and stator. The rotor blades can be fitted to the front of a compressor or be part of a complete compressor driven by its own turbine. The air accelerated by the outer portion of the blades forms a by pass or secondary airflow that is ducted to atmosphere, the main airflow from the inner portion of blade passes through the remainder of the compressor and into the combustion systems. Only one stage of blades is used on the fan of triple spool engines, because the blades are designed to operate at transonic tip speeds. This permits the desired compression ratio to be achieved and not only reduces the weight of engine but also its noise level.

### **Construction**

The construction of the compressor centres around the rotor assembly and casings. The rotor shaft is supported in ball and roller bearings and is coupled to the turbine shaft. The casing assembly consists of a number of cylindrical casings some of which are in two halves to facilitate engine assembly and inspection, these are bolted together to completely house the rotor.

### **Rotors**

The rotor assembly may be of a disc construction (in fig) or of drum, or a combination of both types may be used. The drum type rotor consists of a one or two piece forging on to which are secured the rotor blades. The disc type rotor has the rotor blades attached to separate discs, which are then splined to the rotor shaft and separated by integral or individual spacer rings. In the former type axial thrust and radial load both are taken by the drums whereas in disc type radial load is taken by the disc and axial thrust by the back platform and spacer rings. The accumulated end thrust is taken by the end of the rotor or the end discs.

### **Rotor Blades**

The rotor blades are of aerofoil section (in fig) and are usually designed to give a pressure gradient their length to ensure that the air maintains a fairly uniform axial velocity. The higher pressure towards the tip balances out the centrifugal action of the rotor on the airstream. To obtain thrust condition, it is necessary to twist the blade from root to tip to give the correct angle of incidence at each point. The length of the blades varies from front to rear, the front or low pressure blades being the longest.

### **Stator Blades**

The stator blades are again of aerofoil section and are secured into the compressor casing or into stator blade retaining ring, which are themselves secured to the casings. The blades are often mounted in packs in the front stages and may be shrouded at their tips to minimize the vibrational effect of flow variation on the longer blades. It is also necessary to lock the stator blades in such a manner that they will not rotate around the casings.

### **Operating Conditions**

Each stage of a multi-stage compressor processes certain airflow characteristics that are dissimilar from those of its neighbour: thus, to design a workable and efficient compressor, the characteristics of each stage must be carefully matched. This is a relatively simple process to carry out for one set of conditions ( design mass flow, pressure ratio and rotational speed), but is much more difficult if reasonable matching is to be retained when the compressor is operating over a wide range of conditions such as an aircraft engine encounters.

Outside the design conditions, the flow around the blade tends to degenerate into violent turbulence when the smooth flow of air through the compressor is disturbed. Although the two terms 'stall' and 'surge' are often used synonymously, there is a difference which is mainly a matter of degree. A stall may affect only one stage or even a group of stages, but a compressor surge generally refers to a complete flow breakdown through the compressor.

Compressor blades are designed to produce a given pressure rise and velocity increase over the engine speed range. If something should disturb the pressure, velocity, rotational speed relationship the airflow across the blade profile will break away and create eddies until eventually the blade 'stalls'. This could occur if the airflow was reduced due to icing or a flight manoeuvre, or if the fuel system scheduled too high a fuel flow; damage due to ingestion could, of course, create a similar condition.

If the stall condition of a stage or group of stages continues until all stages are stalled, then the compressor will surge. The transition from a stall to a surge could be so rapid as to be unnoticed; on the other hand, a stall may be so weak as to produce only a slight vibration or poor acceleration or deceleration characteristics.

At low engine speeds or 'off design' speeds, a slight degree of blade stalling invariably occurs in the front stages

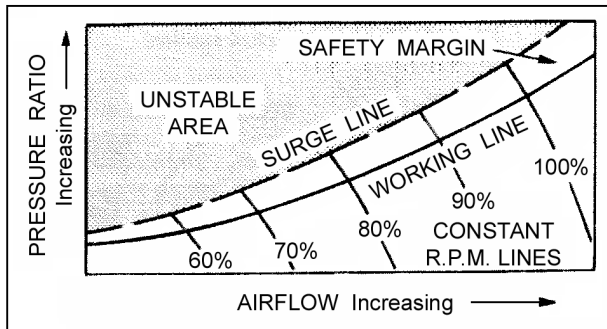

Fig. 1.23. Limits of stable airflow.

**THE DIFFUSER AND AIR ADAPTOR**

**Diffusers**

The function of the diffuser assembly is to direct air from the compressor to the combustion chambers and to change air pressure and velocity as required for best fuel combustion.

The air discharge from a centrifugal impeller enters equally spaced diffuser passages, and at the end of each is a Wrist type of elbow containing four vanes which turn the air 90° into the compressor discharge. The diffuser has boxed type of single casting, with elbows and turning vanes cast integrally. Fig. 1.23. below illustrates a typical diffuser for a centrifugal-flow engine.

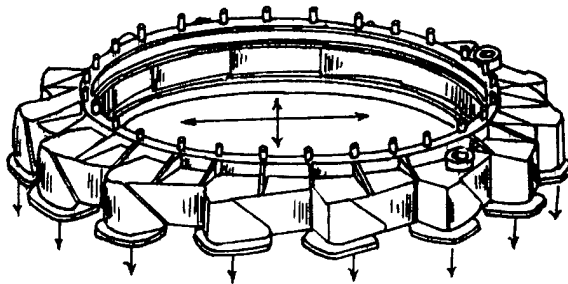

Fig. 1.14. Diffuser for centrifugal flow turbo jet engine.

in slowing the air velocity and increasing the pressure as is desirable at this point of the thermodynamic cycle.

On axial-flow engines, the air adaptor is actually the outlet of the diffuser section. Usually this portion of the assembly is not even named as the air adaptor.

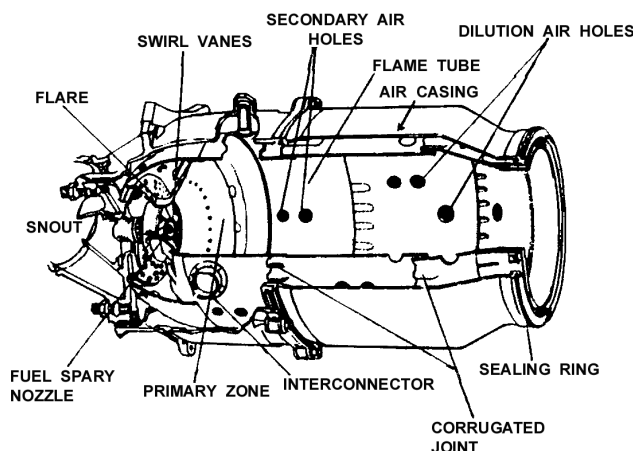

Fig. 1.25. A typical combustion chamber.

of the compressor, even though a system of airflow control may be used. This condition is not harmful or noticeable on engine operation.

A more severe compressor stall is indicated by a rise in turbine gas temperature, vibration or ‘coughing’ of the compressor. A surge is evident by a bang of varying severity from the engine and a rise in turbine gas temperature.

The value of airflow and pressure ratio at which a surge occurs is termed the ‘surge point’. This point is a characteristic of each compressor speed, and a line which joins all the surge points called the ‘surge line’ defines the minimum stable airflow that can be obtained at any rotational speed. A compressor is designed to have a good safety margin between the airflow and the compression ratio at which it will normally be operated and the airflow and compression ratio at which a surge will occur.

The diffuser for an axial-flow engine serves to carry the air from the compressor to the combustion chambers. For an engine equipped with individual “can” type combustion chambers, the diffuser must have a separate outlet shaped to fit the inlet of each combustion chamber. In some axial-flow engines, the diffuser section is called the midframe. It not only contains the diffuser but also provides support for the mid bearing and mountings for the fuel-nozzle assemblies.

**Air Adapters**

Air adapters on a centrifugal-flow engine carry the air from the diffuser to the combustion chambers. They also provide attachment for the fuel nozzles, domes or end caps of the combustion chambers, air adapters aid

**COMBUSTION CHAMBER**

**Introduction**

The amount of fuel added to the air will depend upon the maximum temperature rise required and, as this is limited by the materials from which the turbine blades and nozzles are made, the rise must be in the range of 700 to 1200°C because the air is already heated by the work done during compressor, the temperature rise required at the combustion chamber may be between 500 and 800°C. Since the gas temperature required at the turbine varies with engine speed and in the case of turbo-prop engine upon the power required, the comb. Chamber must also be capable of maintaining stable and sufficient combustion over a wide range of engine operating condition.

**Combustion Process**

Air from the engine compressor enters the combustion chamber at a very high velocity which is further diffused and static pressure increased in the combustion chamber, this is done because the burning of kerosine at normal mixture ratio is only few fts/sec, and any fuel which is

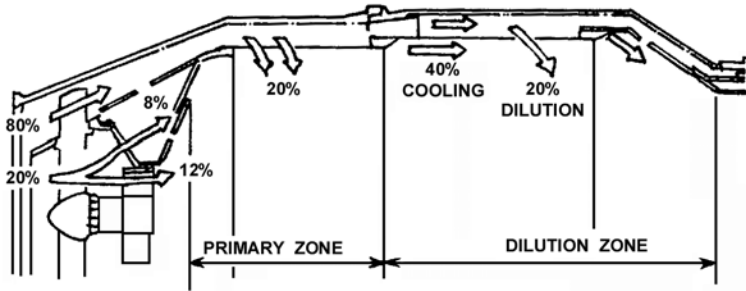

Fig. 1.26. Apportioning the air flow.

by the snout or entry section. Immediately down stream of the snout, are swirl vanes and a perforated flare, through which air passes into the primary combustion zone. The swirling air induces a flow upstream of the centre of the flame tube and promotes the desired recirculation. The air not picked up by the snout flows into the annular space between the flame tube and the air casing.

Through the wall of the flame tube body, adjacent to the combustion zone, are a selected number of holes through which a further 10 to 15% of the main flow of air passes into the primary zone. The air from the swirl vanes and that from the primary air holes inter acts and creates a region of low velocity recirculation. This takes a form of a toroidal vortex similar to a smoke ring and has the effect of stabilizing and anchoring the flame. The recirculating gases hasten the burning of freshly injected fuel droplets by rapidly bringing them to ignition temperature.

It is arranged so that the conical fuel spray from the burner, intersects the recirculation vortex at the centre. This action, together with the general turbulence in the primary zone, greatly assists in bringing up the fuel and mixing it with the incoming air.

The temperature of the combustion gases released by the combustion zone is about 1,800 to 2000°C which is far too hot for entry to the nozzle guide vanes of the turbine. The air not used for combustion, which is therefore introduced progressively into the flame tube. Approx. half of this is used to lower the gas temperature before it enters the turbine and the other half is used for cooling the walls of the flame tube. Combustion should be completed before the dilution air enters the flame tube, otherwise the incoming air will cool the flame and incomplete combustion will result.

An electric spark from an igniter plug initiates combustion and the flame is then self sustained.

### Types Of Combustion Chamber

There are three main types of combustion chamber in use, they are multiple chamber, the turbo annular chamber and the annular chamber.

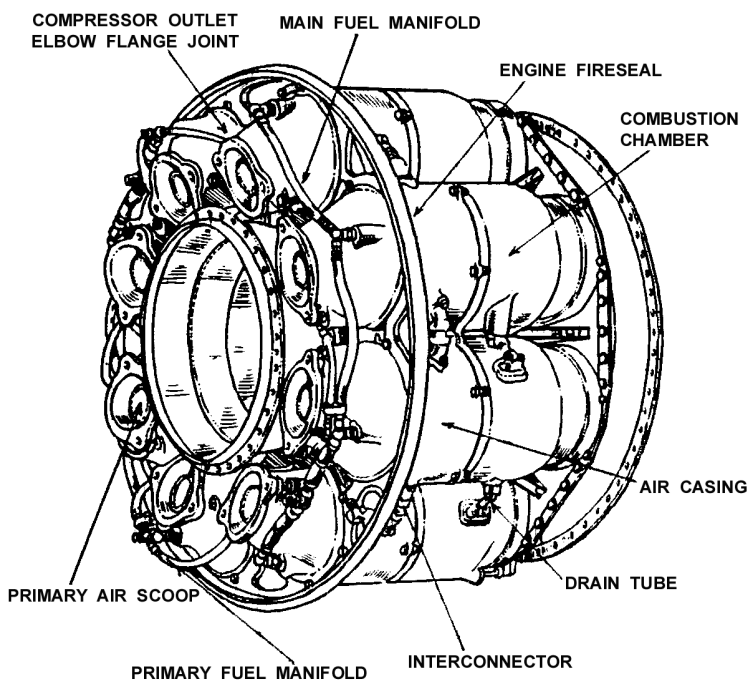

Fig. 1.27. Multiple combustion chamber.

burnt at high velocity will be blown off or away. A region of low axial velocity has therefore to be created in the chamber so that the flame will remain alight throughout the range of energy separating conditions.

In normal operation the over all air/fuel ratio of a combustion chamber can vary between 45% and 30% kerosene however will only burn efficiently at or close to a ratio of 15:1 so the fuel must be burnt with only part of the air entering the chamber, in what is called a primary combustion zone. This is achieved by means of a flame tube (combustion liner) that has various devices for metering the airflow distribution along the chamber.

Approx. 18% of the air mass flow is taken in

### Multiple Combustion Chamber

This type of combustion chamber is used on centrifugal compressor engines and the earlier types of axial flow compressor engines. It is a direct development of the earlier type of whittle combustion chamber. The major difference is that whittle chamber had a reverse flow, but as this created a considerable pressure loss, the straight through multiple chamber was developed by Joseph Lucas Ltd.

The chambers are disposed around the engine (fig. 1.27.) and compressor delivery air is directed by ducts to pass into the individual chamber. Each chamber has an inner flame tube around which, there is an air casing. The air passes through the flame tube snout, and also between the tube and the outer casing.

The separate flame tubes are all interconnected. This allows each tube to operate at the same pressure and also allows combustion to propagate around the flame tubes during engine starting.

### Turbo Annular Combustion Chamber

The turbo annular C.C is a combination of the multiple and annular types. A number of flame tubes are fitted inside a common air casing. The

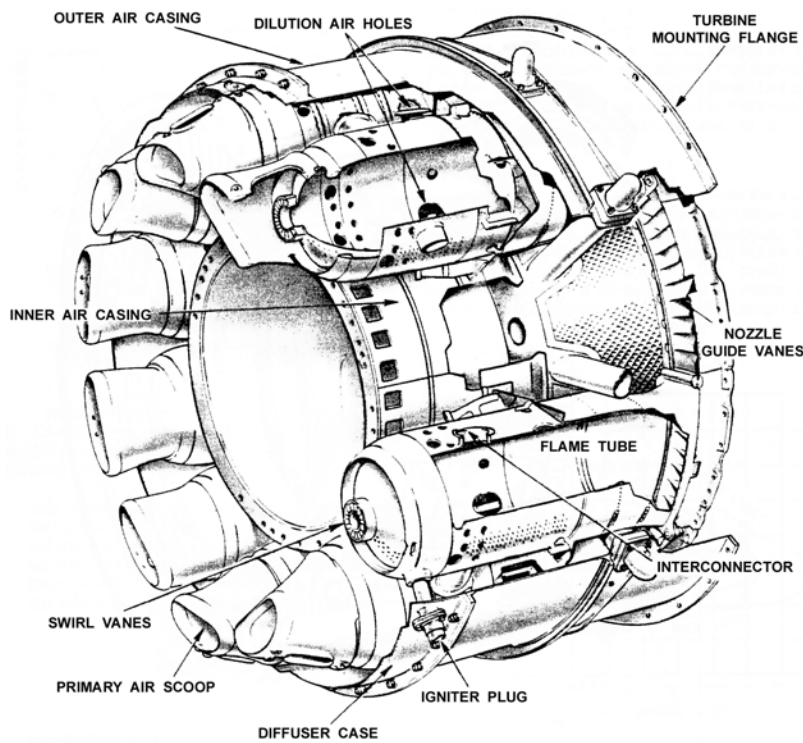

Fig. 1.28. Turbo-annular combustion chamber.

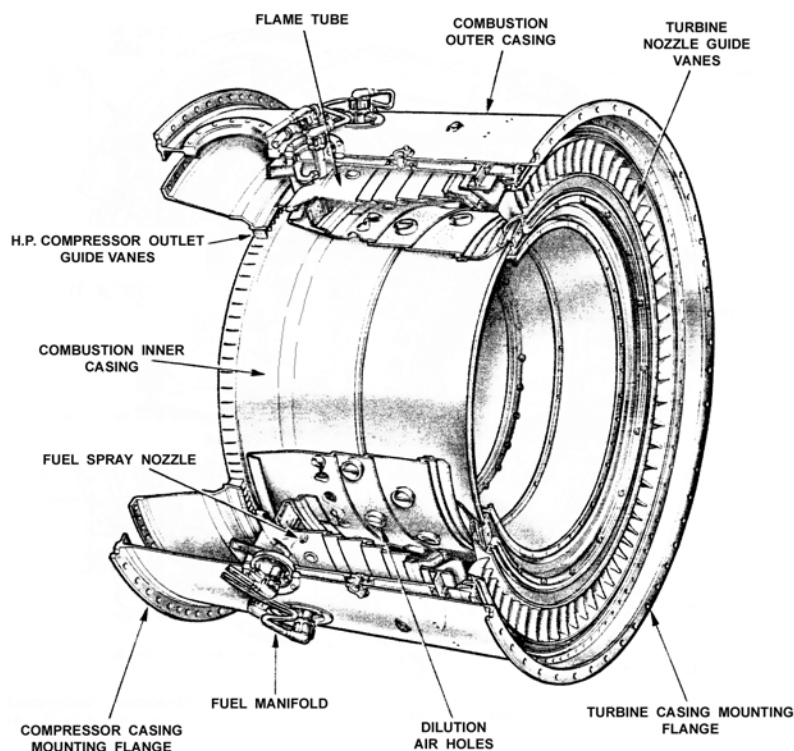

Fig. 1.29. Annular combustion chamber.

airflow is similar to that already described and this arrangement, embodies the case of overhaul and testing of the multiple system with the compactness of annular system. (fig. 1.28).

### Annular Combustion Chamber

This type of combustion chamber consists of a single flame tube, completely annular in form, which is contained in an inner and outer casing (fig. 1.29). The air flow through the flame tube is similar to that previously, described, the chamber being open at the front to the compressor and at the rear to the turbine nozzles.

The main advantage of annular chamber is that, for the same power output, the length of the chamber is only 75% of that of a turbo annular system for an engine of the same diameter, resulting in considerable saving of weight and production cost. Another advantage is that because inter connection are not required the propagation of combustion is improved.

In comparison with a turbo annular combustion system, the wall area of a comparable annular chamber is much less; consequently the amount of cooling air required to prevent the burning of the flame tube wall is less, by approx. 15%. This reduction in cooling air raises the combustion efficiently to virtually eliminate unburnt fuel, and oxidizes the carbon monoxides to non toxic carbon dioxide, thus reducing air pollution.

A high by pass ratio engine will also reduce air pollution since for a given thrust the engine burns less fuel.

### Turbine Nozzle And Nozzle Diaphragm

This diaphragm consists of a group of nozzle vanes welded, between two shroud rings. In the typical nozzle diaphragm, the inner and outer bands contains punched holes to receive the ends of nozzle vanes. The nozzle vanes are usually constructed of high temperature alloy, and they must be highly heat resistant.

In many engines the nozzle vanes are hollow and are formed from stainless steel sheet. They are then welded and ground smooth before being installed between the shroud rings. When there is more than one turbine wheel, additional nozzle diaphragms are installed to direct the hot gases from one wheel to the next. Second third and fourth stage nozzle vanes are often constructed of solid steel alloy. These may be either forged or precision cast.

### Purpose

The purpose of nozzle diaphragm is two fold : (i) it increases the velocity of the hot gases flowing past this point and (ii) it

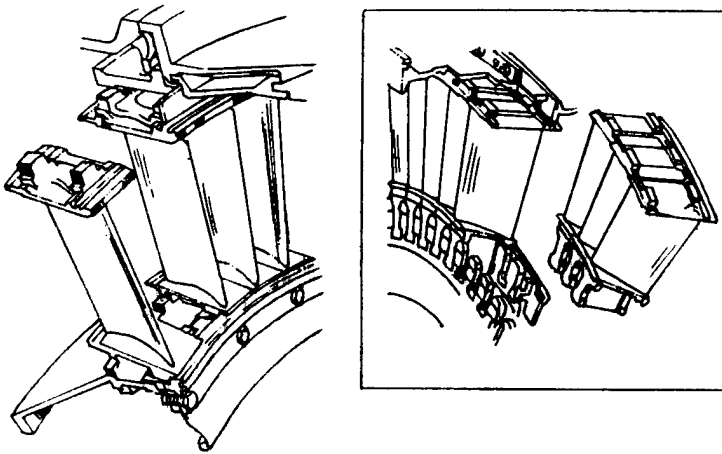

Fig. 1.30. Typical nozzle guide vanes showing their shape and location.

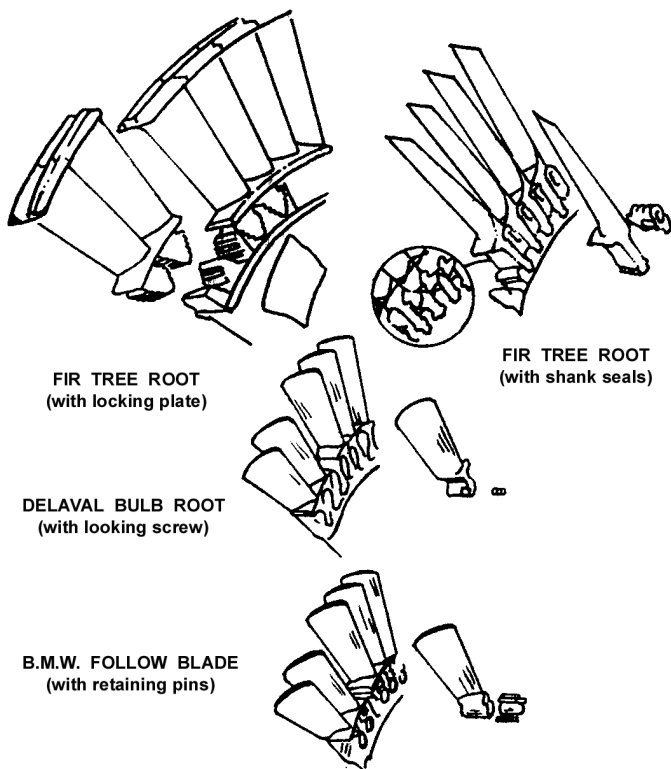

Fig.1.31. Methods of attaching blades to turbine discs.

directs the flow of gases to strike the turbine buckets at the desired angle. The gases flowing through the nozzle diaphragm attain their highest velocity at this point.

The blades or vanes in the nozzle diaphragm are of aerofoil design. In the pure reaction type design, the nozzle blades resemble turbine blades closely. This is particularly true of the nozzle or stator blades (vanes) between the turbines wheels in multi stage turbine assemblies.

## TURBINE Introduction

The turbine has the task of providing the power to drive the compressor and accessories and, in the case of engines which do not make use solely of jet for propulsion, of providing shaft power for a propeller or rotor. It does this by extracting energy from the hot gases released from the combustion system and expanding them to a lower pressure and temperature. High stresses are involved in this process, and for efficient operation, the turbine blade tip may rotate at speeds up to 1300 feet per second.

To produce the driving torque, the turbine may consist of several stages, each employing one row of stationary nozzle guide vanes and one row of moving blades. The no. of stages depends on whether the engine has one shaft or two and on the relation between the power required from the gas flow, the rotational speed at which it must be produced and the diameter of turbine permitted.

The number of shafts varies with the types of engine, high compression ratio engines usually have two shafts, driving high and low pressure compressors. On high bypass ratio fan engines that feature an intermediate pressure system, another turbine is interposed between the high and low pressure turbine thus forming a triple spool system. On some propeller or shaft engines, driving torque is derived from a free power turbine. The shaft driving the propeller or the output shaft to the rotor blade of a helicopter, through a reduction gear, may be mechanically independent of other turbine and compressor shafts.

The bypass engine enables a smaller turbine to be used than in a pure jet engine for a given thrust output and it operates at a higher gas inlet temperature, thereby obtaining important thermal efficiency and power/weight ratio.

The design of the nozzle guide vanes and turbine blade passages is based broadly on aerodynamic considerations, and to obtain optimum efficiency compatible with compressor and combustion design, the nozzle guide vanes and turbine blades are of a basic aerofoil shape. The relationship and juxtaposition of these shapes are such that the turbine functions partly under impulse and partly under reaction condition, that is to say, the turbine blades experience an impulse force caused by the initial impact of the gas on the blades and a reaction force resulting from the expansion

and acceleration of the gas through the blade passages. Normally gas turbine engines do not use either pure impulse or pure reaction turbine blades. With an impulse turbine, the total pressure drop across each stage occurs in the fixed nozzle guide vanes and the effect on the turbine blades is one of momentum only; whereas with a reaction turbine, the total pressure drop occurs through the turbine blade passages. The proportion of each principle incorporated in the design of a turbine is therefore largely dependant on the type of engine in which the turbine is to operate, but in general it is about 50% impulse and 50% reaction. Impulse type turbines are used for cartridges and air starters.

### Construction

The basic components of the turbine are the combustion discharge nozzles, the nozzle guide vanes, the turbine discs and turbine blades. The rotating assembly is carried on roller bearings mounted to a compressor shaft or connected to it by a self aligning coupling.

### Nozzle Guide Vanes

Are of aero foil shape, the passages between adjacent vanes forming a convergent duct. The vanes are located in the turbine casing in a manner that allows for expansion.

The nozzle guide vanes are usually of hollow form and be cooled by passing compressor delivery air through them to reduce the effects of high thermal stresses and gas load.

### Turbine Disc

The turbine disc is a machine forging with an integral shaft or with a flange on to which the shaft may be bolted. The disc also has around its perimeter provision for the attachment to the turbine blades.

To limit the effect of heat conduction from the turbine blades to the disc a flow of cooling air is passed across both sides of each disc.

### Turbine Blades

The turbine blades are of an aerofoil shape. The main air is to provide passages between adjacent blades that gives a steady acceleration of the flow up to the throat where the area is smallest and the velocity reaches that required at exit to produce the required degree of reaction.

High efficiency demands thin trailing edges to the sections but a compromise has to be made so as to prevent the blades cracking due to temperature changes during engine starting and stopping.

The method of attaching the blades to the turbine disc is of considerable importance, since the stress in the disc around the fixing or in the blade root has an important bearing on limiting rim speed. Various methods of blade attachment are

- (1) Fir tree Root (with locking plate)
- (2) Fir tree Root (with shank seals).
- (3) De laval By it Root (with locking screw).
- (4) B.M.W.hollow blade (with retaining pins).

Now a days majority of gas turbine use fir tree root type attaching method.

To reduce the loss of efficiency due to gas leakage, across the blade tips, a shroud is often fitted this is formed by forging small segment at the tip of each blade, so that when all the blades are fitted to the disc, the segment form a peripheral ring around the blade tips.

On a fan engine, where the fan is aft (rear) mounted the blade forming the fan present an additional thermal problem. This is because the outer portion of each blade operation is in a duct through which passes a cool air stream, while the inner portion operates in the normal gas stream to extract the energy for accelerating the fan airflow.

### THE EXHAUST CONE

The exhaust cone is located directly behind the turbine wheel and its main function is to collect discharge gases from the turbine wheel and expel them at the correct velocity. The exhaust cone consists of a stainless steel outer shell and central cone supported from the shell by four stream lined struts or fins is to straighten out the airflow from approx. 45° to an axial direction. Air flowing through this section decreases in velocity and increases in pressure.

The outer surface of the exhaust cone is insulated in most installations and many different types of insulation are used. A typical arrangement consists of four layers of Al foil, each separated from the next by a layer of bronze screening. The insulation reduces the heat losses that would normally escape through the exhaust cone. The insulation also protects adjacent aircraft structures and equipment from damage caused by heat.

When the gas-turbine engine is delivered by the manufacturer to the ultimate consumer, the exhaust cone is the terminating component of the basic engine. In order to operate the engine and obtain the required performance, however, it is necessary to use a tail pipe and exhaust nozzle. The length of the exhaust pipe or tail pipe varies with each airplane installation, and therefore, by necessity, the pipe must be manufactured by the air-frame manufacturer.

### THE THRUST REVERSER

Jet engines installed in jet airlines are equipped with thrust reversers to provide a braking action after the airplane has landed. The thrust reverser blocks gas flow to the rear and directs it forward to produce reverse thrust up to 5,000 lb. or more. The reverse thrust is produced when the air baffle doors or " clamshells " are moved into the gas stream by actuating cylinders controlled by the reverse thrust lever in the cockpit. Fig. 1.32. below is a drawing of a typical thrust reverser unit designed for use with the General Electric CJ805 jet engine.

## ACCESSORIES SECTION

### Locations

Early type of engines usually had the accessory drive sections located at the nose of the engine, where it had the effect of limiting the available area for air intake. This was particularly true on axial flow engines.

Present designs place the main accessory drive section at the bottom of the engine, and fitted closely against the case. The accessory drive is geared to the shaft of the high pressure compressor.

### Engine Driven Accessories

Includes the accessories needed for engine operation and also those required for the operation of a/c. The following is a list of accessories commonly driven by the engine and mounted on the accessory section.

- i. Engine starter (connected to the engine during starting).
- ii. Generator
- iii. Fuel Pump
- iv. Emergency fuel pump
- v. After burner fuel pump
- vi. Techo meter generator
- vii. Fuel control unit
- viii. Air bleed governor
- ix. Oil pump and scavenge pump
- x. Hydraulic pump.

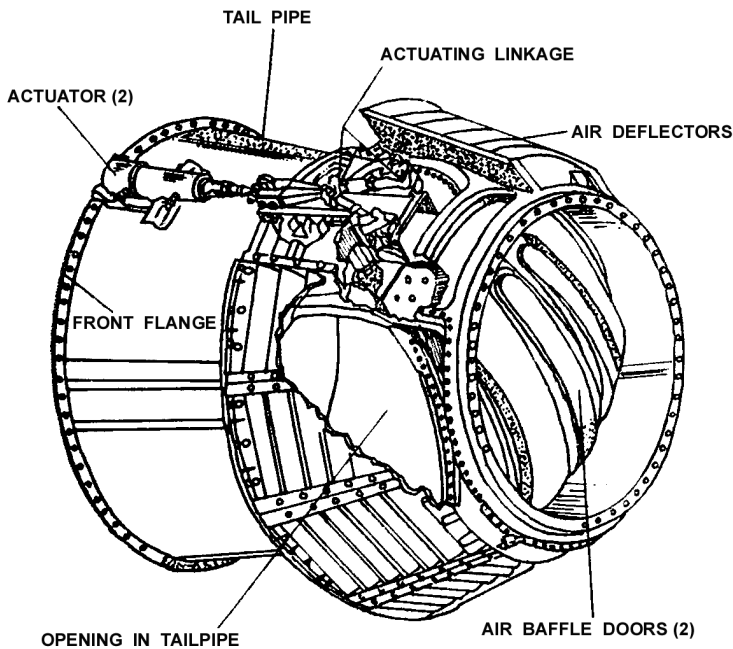

Fig. 1.32. Thrust reverser unit. (General Electric Company)

increased velocity of the jet leaving the propelling nozzle and therefore increases the engine thrust.

As the temperature of the after burning flame can be in excess of 1700 deg. C., the burners are usually arranged so that the flame is concentrated around the axis of the jet pipe. This allows a proportion of the turbine discharge gas to flow along the wall of the jet pipe and thus maintain the wall temperature at a safe value.

The area of the after burning jet pipe is large than a normal jet pipe would be for the same engine, to obtain a reduced velocity gas stream. To provide for operation under all conditions, an after burning jet pipe is fitted with either a two-position or a variable-area propelling nozzle. The nozzle is closed during non-after burning operation, but when after burning is selected the gas temperature increases and the nozzle opens to give an exit area suitable for the resultant increase in the volume of the gas stream. This prevents any increase in pressure occurring that would affect the functioning of the engine and enables after burning to be used over a wide range of engine speeds.

The thrust of an after burning engine, without after burning in operation, is slightly less than that of a similar engine not fitted with after burning equipment; this is due to the added restrictions in the jet pipe. The overall weight of the power plant is also increased because of the heavier jet pipe and after burning equipment.

After burning is achieved on bypass engines by mixing the bypass and turbine streams before the afterburner fuel injection and stabilizer system is reached so that the combustion takes place in the mixed exhaust stream. An alternative method is to inject the fuel and stabilize the flame in the individual bypass and turbine streams, burning the available gasses up to a common exit temperature at the final nozzle. In this method, the fuel injection is scheduled separately to the individual streams and it is normal to provide some form of interconnection between the flame stabilizers in the hot and cold streams to assist the combustion processes in the cold bypass air.

Some gas-turbine engines have one accessory power section, while others may have more. For example, one modern engine drives most of the accessories from a power takeoff at the bottom of the engine but also has an auxiliary accessory driven at the front of the engine. Two or three of the smaller accessories are driven from this front accessory section.

### AFTERBURNING

After burning (or reheat) is a method of augmenting the basic thrust of an engine to improve the aircraft-take off, climb and (for military aircraft) combat performance. The increased power could be obtained by the use of a larger engine, but as this would increase the weight, frontal area and specific fuel consumption, after burning provides the best method of thrust augmentation for short periods.

After burning consists of the introduction and burning of fuel between the engine turbine and the jet pipe propelling nozzle utilizing the unburned oxygen in the exhaust gas to support combustion. The resultant increase in the temperature of the exhaust gas gives an

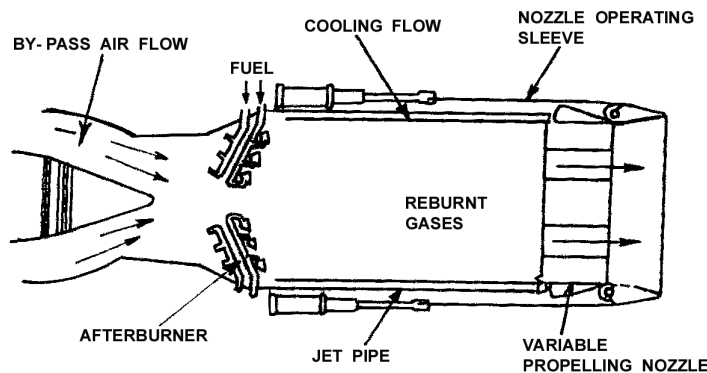

Fig. 1.33. Principle of after burning.

An atomized fuel spray is fed into the jet pipe through a number of burners, which are so arranged as to distribute the fuel evenly over the flame area. Combustion is then initiated by a catalytic igniter which creates a flame as a result of the chemical reaction of fuel/air mixture being sprayed on to a platinum-based element by an igniter plug adjacent to the burner, or by a hot streak of flame that originates in the engine combustion chamber; this latter method known as hot shot ignition. Once combustion is initiated the gas temperature increases and the expanding gases accelerated through the enlarged area propelling nozzle to provide the additional thrust.

In view of the high temperature of the gases entering the jet pipe from the turbine, it might be assumed that the mixture would ignite spontaneously. This is not so, for although cool flames form at temperatures up to 700 deg. C., combustion will not take place below 800 deg C. If, however, the conditions were such that spontaneous ignition could be effected at sea level, it is unlikely that it could be effected at altitude where the atmospheric pressure is low. The spark or flame that initiates combustion must be of such intensity that a light-up can be obtained at considerable altitudes.

For smooth functioning of the system, a stable flame that will burn steadily over a wide range of mixture strengths and gas flows is required. The mixture must also be easy to ignite under all conditions of flight, and combustion must be maintained with the minimum loss of pressure.

**Thrust Increase**

The increase in thrust due to after burning depends solely upon the ratio of the absolute jet pipe temperatures before and after extra fuel is burnt. For example, neglecting small losses due to the afterburner equipment and gas flow momentum changes, the thrust increase may be calculated as follows.

Assuming a gas temperature before after burning of 640 deg. C (913 deg K) and with after burning of 1269 deg. C (1542 deg. K) then the temperature ratio =  $(1542/913) = 1.69$

The velocity of the jet stream increases as the square root of the temperature ratio. Therefore, the jet velocity  $1.69 = 1.3$ . Thus, the jet stream velocity is increased by 30 percent and the increase in static thrust, in its instance, is also 30%.

Static thrust increases of up to 70% are obtainable from bypass engines fitted with after burning equipment, and at high forward speeds several times this amount of thrust boost can be obtained. High thrust boosts can be achieved on by pass engines because of the large amount of exhaust oxygen in the gas stream and the low initial temperature of the exhaust gases.

It is not possible, however, to go on increasing the amount of fuel that is burnt in the jet pipe so that all the available oxygen is used, because the jet pipe would not withstand the high temperatures that would be incurred.

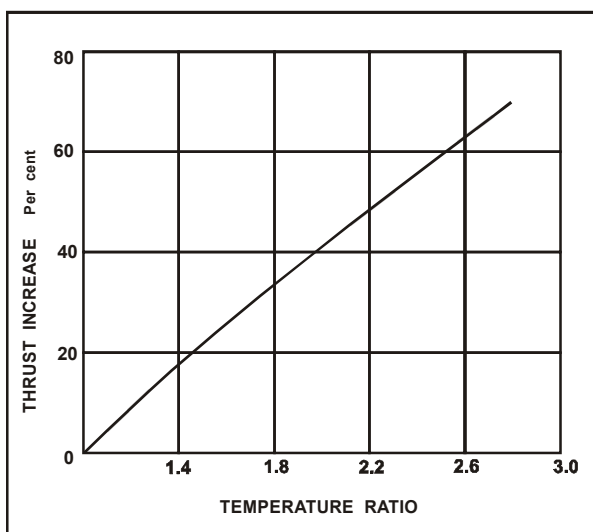

Fig. 1.34. Thrust increase and temperature ratio.

**MATERIAL FOR GAS TURBINE ENGINES**

**Chemical Elements**

The most commonly used elements in the manufacture of metals and alloys for gas turbine engines are listed here with their symbols : Carbon (C); Silicon (Si); Manganese (Mn); Chromium (Cr); Nickel (Ni); Cobalt (Co); Molybdenum



(M) Tungsten (W); Colombian (Cb); Titanium (Ti); Nitrogen (N); Copper (Cu); Iron (Fe); Aluminium (Al).

This list is not meant to include all possible elements used in high-temperature alloys, but it indicates the types of elements required.

The three characteristics that metallurgists search for in the metals for high-temperature applications are Oxidation resistance, high-temperature strength, and corrosion resistance. Probably the most vital of these three characteristics is the capacity to resist oxidation, because structural strength is useless if a metal rapidly burns away. At jet-engine operating temperature, ordinary steel burns like paper; and tungsten, molybdenum; and Colombian oxidize quickly, as do most high-melting-point metals.

For years manufacturers have worked closely with the steel mills in developing research data that would serve as a guide to the evolution of new alloys. Today, at least 20% high-temperature alloys are used in the fabrication of components for power plants. These metals may be classified into four groups;

- (1) Chrome-nickel steels,
- (2) Chrome steels,
- (3) Nickel-base alloys and
- (4) Cobalt-base alloys.

### **Chrome-Nickel Steels**

The chrome-nickel steels contain these elements in approximately 18:8 ratios and are commonly referred to as "austenitic steels". This description refers to their crystalline structure, in which the ingredients are said to be in solid solution so that each crystal is composed of an intimate mixture of the constituents.

This group of steels is most widely used for high-temperature applications because of its good characteristics of oxidation and corrosion resistance and of high strength at elevated temperatures. These steels have about six times the electrical resistance of ordinary steels and respond readily to welding techniques. However, since they expand 50 percent faster than plain steels and conduct heat only half as fast, they require special care during welding to prevent distortion. They do not need heat-treatment after welding to develop maximum physical strength.

These steels are nonmagnetic and cannot be hardened by heat-treatment. They may be hardened by cold-working, and then they become slightly magnetic. Cold-working enhances their structural strength at the cost of ductility. They are difficult to machine unless they contain added amounts of sulphur or selenium.

When subjected to temperatures above 800° F, they tend to precipitate carbides in their grain boundaries, thus lowering their resistance to corrosion. The corrosion resistance may be restored by heating them to 1850 to 1900° F and cooling them quickly, or they may be protected against the formation of harmful carbide precipitation by the addition of Colombian or titanium to their formulas.

Chrome Nickel steels are suitable for parts such as high-pressure compressor casings, combustion casings, turbine casings, and similar parts where extreme temperatures are not encountered. High-temperature stainless steels are also employed for compressor blading, compressor disks, turbine disks, exhaust cones, thrust reversals afterburner casings, and miscellaneous sheet metal parts. The principal disadvantage of chrome-nickel stainless steels is the weight. For this reason, titanium alloys are often used where the temperature is not excessive for the material.

### **Chromium Steels**

The straight alloys, containing no nickel, are either martensitic or ferritic in crystalline structure, depending upon their hardening characteristics. Those containing upto 14% chromium harden intensely if they are allowed to cool rapidly from high temperatures, forming a hard, relatively brittle substance called martensite. Because these alloys respond to heat-treatment, they are capable of being given a wide range of mechanical properties such as tensile strength and hardness.

Those chromium steels containing from 17 to 30 percent chromium do not respond to heat-treatment or cooling and remain essentially ferritic at all times. The intermediate types, containing between 14 and 17 percent chromium, behave in a manner that depends upon their exact chromium and carbon contents.

Chromium contents up to 4 percent do not increase corrosion resistance. Amounts from 4 to 10 percent improve resistance to corrosion appreciably. Chromium percentages from 10 to 30 percent are designated when oxidation resistance at high temperatures is required.

The steels with chromium contents of 5 to 30 percent are magnetic in all conditions. They exhibit distinctly inferior creep resistance compared with the chrome-nickel stainless steels. The 17 percent chromium steels have excellent oxidation and corrosion resistance and may be used at temperatures up to 1500° F. The 25% chromium content steel is designated for severe heat and corrosion applications and is good for applications where temperatures reach 2000° F.

All the straight chrome steels are more difficult to weld than the chrome-nickel types because the welding heat leaves them in a brittle condition. They have about the same coefficients of expansion as ordinary steel, with several times the electrical resistance and slightly lower melting points. They tend to become brittle from welding heat in two ways : by slow cooling from around the 1200° F range, and by grain growth produced by holding them over 1650° F. The first type of embrittlement may be eliminated by quick cooling from above 1200° F. The second type cannot be remedied but may be avoided by careful welding techniques.

From straight chrome steel, jet-engine case weldments and bearing-housing assemblies are built for Pratt & Whitney turbojet engine. These are fabricated from welded alloys of Type 410. Additional jet-engine detail fittings and components are built from Type-415 and used in applications where temperature is not a critical factor.

**Nickel Base Alloys**

The nickel-base alloy contain between 70 and 80 percent nickel and cannot properly be called “steels” because of their small quantities of iron. In this group of alloys, many of which are called “super alloys”, are the Nimonics, M-252, GMR-235, the Hastelloys, Nichrome, Rex 400, K42 B the Inconels, Waspalloy, Rene 41, Multi-alloy, Refract alloy 26, the Udimets, and Unitemp 1735. These alloys have been tailored for high-temperature and some offer excellent oxidation and corrosion resistance at temperatures of over 2100°F.

**Inconel**

These alloys can be cold-worked, hot-worked, or forged without difficulty and can also be welded and machined. Various types of the Inconel alloys are used for combustion chambers, transition liners, turbine nozzle parts, and turbine buckets.

**The Nimonic**

The nimonic alloys, numbered 75, 80, 80A and 90, are of British manufacture and contain a major percentage of nickel, with chromium as the next most important element. Nimonic 90 utilizes a large percentage of cobalt as an alloying element. The Nimonic alloys are largely used for the hot parts of gas-turbine engines, such as combustion chambers and turbine nozzles.

**GMR-235**

GMR-235 contains about 55 percent nickel, 15.5% chromium and 10 percent iron with smaller portions of molybdenum aluminium, and titanium. It is of low strategic-alloy content, that is, it contains neither cobalt nor Columbium; hence it can be manufactured even though these metals are not available. GMR-235 was developed by the General Motors Corporation primarily for gas turbine wheels, buckets, and nozzle vanes operating at temperatures in excess of 1400° F. An improvement of this alloy, GMR-235, contains increased amounts of aluminium and titanium, and less iron.

**The Hastelloys**

Designated A, B, C, R-235. W, and X, are nickel-base alloys developed and manufactured by the Haynes Stellite Company, a Division of the Union Carbide Company. These alloys contains large % of molybdenum. These alloys are used in various applications where high temperature and corrosion resistance are desirable.

**Waspalloy**

Waspalloy was originally developed by the Pratt & Whitney Aircraft Division of United Aircraft Corporation for use in the manufacture of turbine buckets. It is traditional super alloy suitable for use in the 1200 to 1600°F range although it retains good strength at higher temperatures. This alloy is also used for turbine disks and other heavy forging in jet engines.

**The Udimet**

Alloy, manufactured by special metals, Incorporated are super alloys of high strength, corrosion resistance, and high temperature resistance. Udimet 500 is used for turbine buckets and small integral gas turbines. Udimet 700 is suitable for the 1400 to 1800°F range and can be used for a short time upto 2000°F. It is used for turbine buckets and for turbine disks in advanced jet engines. Udimet N-115 is one of the strongest wrought super alloys and is used for turbine buckets in applications requiring extended service upto 1850°F.

**Cobalt Base Alloys**

Cobalt-base alloys, also called super alloys, are designated for use where high-temperature strength and corrosion resistance are important. These alloys usually contain substantial amounts of tungsten, nickel, chromium, and molybdenum in addition to cobalt. Some of the alloys contain either tungsten or molybdenum but not both.

Haynes Stellite No.25 (HS-25) is used to build the eyelid assemblies for afterburners and afterburner flame holders. It has excellent strength and resistance to oxidation at high temperatures. It also exhibits good ductility and can be worked both hot and cold. It has oxidation and carburization resistance for service upto 1900° F.

Haynes Stellite Alloy no.21 (HS-25) is resistant to oxidizing and reducing atmospheres upto 2100°F. It has excellent strength which is maintained through a wide range of temperatures and thermal shock conditions. Haynes Stellite No.31 (HS-31) is a casting alloy, and has good creep, endurance, and stress-rupture properties.

Another cobalt-base alloy manufactured by the Haynes Stellite Company is Alloy No.151. This alloy has excellent properties at high temperatures and is suitable for turbine blade applications upto 1800°F.

**Variations In Alloy Properties**

It must be emphasized that the properties of high-temperature alloys are not imparted merely by the mixing of various metallic elements. The elements are most important ; however, the type of heat treatment and working applied to the alloy is also essential.

Among some of the treatments employed for developing desired characteristics in the super alloys are solution heat treating, precipitation hardening, strain hardening, cold-working and hot-working. Some of these processes are time-consuming and complicated, hence they add to the cost of the material. It is important to note, however, that without the required treatment a particular alloy will not give the specified service.

**Sintered Mesh Porous Media**

A rather new material in its applications to jet engines is a sintered mesh sheet constructed of two or more layers of

mesh manufactured from high-temperature alloys N-155 or L-605 and sinter bonded. This material is used primarily for transpiration cooling in high temperature zones.

Transpiration cooling, as the name implies, is the cooling which results from passing a fluid, either liquid or gas, through a porous media to remove heat from the porous surface. The porous media must have a large internal surface area for heat transfer to permit an efficient heat removal with a minimum of coolant.

The major application in the aircraft field are found in turbojet engines. Afterburner liners as well as the liners of combustion chambers have been fabricated media.

Another important application in turbojet engines is the fabrication of transpiration-cooled turbine blades from porous media.

### **COMPARATIVE ADVANTAGES AND DISADVANTAGES OF GAS TURBINE ENGINES**

In its present forms, the gas turbine, either propeller-drive or pure jet, has numerous attractive features that have been mentioned frequently. These may be reviewed briefly as follows.

#### **Advantages**

##### *Freedom From Vibration*

This permits lighter propeller sections and mounting structure. Vibration is reduced by the elimination of reciprocating parts such as connecting rods and pistons.

##### *Simplicity Of Control*

Only one lever is required for controlling the speed and power of the unit.

##### *No Spark Plugs Required Except For Starting*

Such surfaces add weight and drag. Very small coolers for lubricating oil are used on large jet engines and turboprop engines.

##### *Negligible Cooling Air Required*

Conventional engines require from five to eight times as much air for cooling as is required for power production. The acceleration of this air to airplane speed represents an appreciable loss of power, particularly in climb, even though much of this may be recovered later by the use of carefully designed radiators.

##### *No Spark Plugs Required Except For Starting*

After combustion is once established, it is self supporting.

##### *No Carburetors*

Hence there is no carburetor icing and no mixture controls. There is some question as to this advantage, since large gas turbines do require very complex fuel-control units. The automatic features of these units compensate for their complexity, however.

##### *Available Supply Of Compressed Air*

This air is used for driving cabin superchargers and small turbines and for anti-icing purposes.

##### *Decreased Fire Hazard*

Fuels used for gas turbines are usually less volatile than the high-octain fuels used in reciprocating engines.

##### *Lower Specific Weight*

A gas turbine may develop several times as much power as a reciprocating engine of the same weight.

##### *Lower Oil Consumption*

#### **DISADVANTAGES**

##### *HIGH SPECIFIC FUEL CONSUMPTION AT LOW AIRSPEEDS*

This applies chiefly to pure jet engines. Turboprop engines have performance comparable to reciprocating engines in some instances, since they have attained specific fuel consumption as low as 0.40 lb per hp per hr.

##### *Inefficient Operation At Low Power Levels*

##### *Slow Acceleration From Minimum Speed*

This condition applies chiefly to turbojet engines. Turboprop and turboprop engines are able to accelerate quite rapidly.

##### *High Starting Power Requirements*

Starting large gas-turbine engines has been a problem in the past; however, starters have been developed within the past few years which make it relatively simple.

##### *High Cost Of Manufacture*

Although the gas turbine is much simpler in operation than the piston engine, the special materials and manufacturing processes needed make the cost of the gas turbine much higher.

##### *Susceptibility To Damage By Foreign Material*

Such material is rapidly drawn into the air inlet.

#### **BASIC DIFFERENCES-GAS TURBINE V/S RECIPROCATING ENGINE**

The basic differences between the gas-turbine engine and the reciprocating engine may be classified into five main groups.

##### **Aerodynamic (Advantages)**

Smaller nacelles possible; negligible cooling power required; high speed jet is a more efficient propulsive means than propeller at high flight speeds.

##### **Disadvantages**

A high speed jet is a less efficient propulsive means than a propeller at lower flight speeds and during takeoff. The

development of turboprop and turbofan engines has made it possible to combine the advantages of the turbine engines with the efficiency of the propeller for lower speeds and for takeoff.

#### **Weight (Advantages)**

Turbine engines are considerably lighter than reciprocating engines for the same power output. Turbojet engines have been developed with a weight/power ratio of less than 0.13 lb. per lb. of thrust. Turboprop engines have attained 0.39 lb. per equivalent shaft horsepower (eshp) in comparison with reciprocating engines which usually have a weight/power ratio of approximately 1.0 lb. per hp or more.

#### **Fuel Consumption (Neutral Characteristics)**

Best specific fuel consumption occurs near maximum output. (Best specific fuel consumption reciprocating engines occurs at about one-half maximum power.) At a given flight speed, specific fuel consumption of the turbojet engine tends to decrease with altitude. The specific fuel consumption for turboprop engines is comparable to that of the best reciprocating engines. It is likely that continued development will produce a turboprop engine with much better specific fuel consumption than any reciprocating engine. Turbojet engines have been developed to a point where specific fuel consumption is excellent, at operating speeds and altitudes, they are more efficient than of 1:2:1 and have brought about specific fuel-consumption figures of less than 0.70 lb. per pound of static thrust.

#### **Disadvantages**

Best fuel consumption is in general is poorer for the turbojet engine; however this disadvantage appears to be decreasing rapidly.

#### **Output**

Operation of the gas turbine engine at varying altitudes is somewhere between that of an unsupercharged and supercharged reciprocating engine. That is, the turbine engine is more adaptable to varying altitudes than the unsupercharged engine and perhaps a little less adaptable than the supercharged reciprocating engine.

#### **General (Advantages)**

Low power plant vibration, relatively constant speed over a wide range of output.

#### **Disadvantages**

High engine speed (advantageous for generator drive)

#### **PERFORMANCE COMPARISON**

A comparison of the performance of aircraft powered by reciprocating turboprop, and turbojet engines indicates that for a cruising altitude of 35,000 ft :

- 1) Aircraft with top speeds below 335 mph achieve their maximum range when powered by reciprocating engines.
- 2) Aircraft with top speeds above 610 mph achieve their maximum range when powered by turbojet engines.
- 3) Aircraft with speeds between those specified in the foregoing statements in general achieve their maximum range when powered by turboprop or turbofan engines.

#### **Axial Flow V/S Centrifugal Flow**

Within the classification of turbojet engines, some engines have advantages over other. At the present stage of development of these engines, the axial-flow type has the following advantages over the centrifugal-flow type:

#### **Lower Specific Fuel Consumption**

This advantage is quite important, since turbine powered aircraft are now designed to fly vast distances without refuelling. The lower fuel consumption is accomplished with the axial-flow engine because the axial compressor makes possible higher pressure ratio. This is particularly true of the turbofan engines.

#### **Smaller Diameter Or Frontal Area**

This characteristic makes the axial-flow engine more suitable for wing installation.

The following are some of the advantages of the centrifugal flow engine over the axial-flow type :

#### **Simple Manufacture And Fewer Parts**

This reduces initial cost and maintenance.

#### **Lower Specific Weight**

A centrifugal engine with an equivalent compression ratio may be lower in weight for the amount of thrust.

#### **Faster Installation And Removal**

No close fitting ducts to engine are necessary.

#### **More Effective Water Injection**

On this type of engine the water can be injected directly into the compressor, where as in an axial flow engine, water is injected into the C.C.

### Faster Acceleration Of The Rotor Section

The advantages of higher compressor ratios possible with the axial flow engines will make this type of engine more desirable, especially for high performance a/c.

Turbofan or by pass engines increase air mass flow by feeding additional air into the jet stream directly to the rear of the turbine. This results in thrust augmentation because a greater mass of air is accelerated than would be the case with the simple jet engine.

### PERFORMANCE OF GASTURBINE ENGINES

The performance of the turbojet engine is measured in thrust produced at the propelling nozzle or nozzles, and that of the turbo-propeller engine is measured in shaft horsepower (s.h.p.) produced at the propeller shaft. However, both types are in the main assessed on the amount of thrust or s.h.p. they develop for a given weight, fuel consumption, and frontal area.

Since the thrust or s.h.p. developed is dependent on the mass of air entering the engine and the acceleration imparted to it during the engine cycle, it is obviously influenced, as subsequently described, by such variables as the forward speed of the aircraft, altitude, and climatic conditions. These variables influence the efficiency of the air intake, the compressor, the turbine, and the jet pipe; consequently, the gas energy available for the production of thrust or s.h.p. also varies.

In the interest of fuel economy and aircraft range, the thrust or s.h.p. per unit weight should be at its maximum with the fuel consumption as low as possible. This factor, known as the specific fuel consumption (s.f.c.), is expressed in pounds of fuel per hour per pound of net thrust of s.h.p and is determined by the thermal and propulsive efficiency of the engine.

Whereas the thermal efficiency is often referred to as the internal efficiency of the engine, the propulsion efficiency is referred to as the external efficiency.

The thermal and propulsive efficiency also influence, to a large extent, the size of the compressor and turbine thus determining the weight and diameter of the engine for a given output.

### ENGINE THRUST ON THE TEST BENCH

The thrust of the turbojet engine on the test bench differs somewhat from that during flight. On the test bench the thrust is mainly the product of the mass of air passing through the engine and the jet velocity at the propelling nozzle; whereas in flight it is mainly the product of the mass of air passing through the engine, and the jet velocity less the forward speed of the aircraft. Algebraically, the thrust of the stationary engine is expressed as  $Wv_j/g$

where

$W$  = mass of air (lb.per.sec.)

$v_j$  = jet velocity at propelling nozzle (ft.per.sec.)

$g$  = gravitational constant 32.2.

Engine running under choked nozzle condition drive additional thrust from the excess pressure acting over the propelling nozzle and this is expressed as  $(p - P_o) A$ , where

$p$  = static pressure at propelling nozzle (lb.per.sq.in)

$P_o$  = atmospheric pressure (lb.per.sq.in.)

$A$  = area of propelling nozzle (sq.in.)

Thus, the total thrust  $F = (p - P_o) A + Wv_j/g$

From the formula it will be seen that the thrust of the engine can be increased either by increasing the mass of air passing through the engine or by increasing the jet velocity. Increase in mass airflow may be obtained by using water injection and increase in jet velocity by using after burning.

As the air density changes, mass of air entering the engine for a given engine speed changes. Thus, when comparing the performance of similar engines, a correction to the observed readings is required for any variation from the I.S.A. conditions.

The correction for a turbojet engine is :

$$\text{Thrust (lb.) (corrected)} = \text{thrust (lb.) (observed)} \times \frac{29.99}{P_o}$$

where  $P_o$  = atmospheric pressure in Hg (observed).

The observed performance of the turbo-propeller engine is also corrected to I.S.A. conditions, but due to the rating being different. For example, s.h.p. (corrected) = s.h.p. (observed)  $\times \frac{29.99}{P_o} \times \frac{273+15}{273+T_o}$

where  $P_o$  = atmospheric pressure in Hg (observed).

$T_o$  = atmospheric temperature deg C. (observed).

In practice there is always a certain amount of jet thrust in the total output of the turbo-propeller engine and this must be added to the s.h.p.

The total equivalent horsepower is denoted by t.e.h.p. and is the s.h.p. plus the s.h.p equivalent to the net jet thrust.

$$\text{t.e.h.p.} = \text{s.h.p.} + \frac{\text{jet thrust lb.}}{2.6}$$

### COMPARISON BETWEEN THRUST AND HORSEPOWER

Because the turbojet engine is rated in thrust and the turbo-propeller engine in s.h.p. no direct comparison between

the two can be made without a power conversion factor. However, since the turbo-propeller engine receives its thrust mainly from the propeller, a comparison can be made by converting the horsepower developed by the engine to thrust or the thrust developed by the turbojet engine to t.h.p., that is, by converting work to force or force to work. For this purpose, it is necessary to take into account the speed of the aircraft.

The t.h.p. is expressed as  $FV/550$  ft.per.sec.  
 where  $F$  = lb.of thrust.  
 $V$  = aircraft speed (ft.per.sec.)

Since one horsepower is equal to 550 ft.lb.per.sec. and 550 ft.per.sec. is equivalent to 375 miles per hour, it can be seen from the above formula that one lb.of thrust equals one t.h.p. at 375 m.p.h. It is also common to quote the speed in knots (nautical miles); one knot is equal to 1.1515 m.h.p. or one pound of thrust is equal to one t.h.p. at 325 knots.

Thus if a turbojet engine produces 5,000 lb. of net thrust at an aircraft speed of 600 m.p.h. the t.h.p. would be

$$\frac{5,000 \times 600}{375} = 8,000$$

However, if the same thrust was being produced by a turbo-propeller engine with a propeller efficiency of 55 per cent at the same flight speed of 600 m.p.h., then the t.h.p. would be

$$\frac{8,000 \times 100}{55} = 14,545$$

### ENGINE THRUST IN FLIGHT

Since reference will be made to gross thrust, momentum drag, and net thrust it may be helpful at this stage to define these terms.

The gross or total thrust is the reaction to the momentum of the jet velocity, expressed as  $(p - P_0) A + Wv_j$ . The momentum or intake drag is the drag due to the momentum of the air passing into the engine relative to aircraft velocity, expressed as  $WV/g$ .

The net thrust or resultant force acting on the aircraft in flight is the difference between the gross thrust and the momentum drag.

It was stated that the thrust of a stationary engine is mainly the product of the mass of air passing through the engine and the jet velocity at the propelling nozzle. This is expressed algebraically as  $(p - P_0) A + Wv_j/g$  i.e. gross or total thrust. Under flight conditions, momentum drag must be taken into account and subtracted from gross thrust. Therefore, simplifying, net thrust can be expressed as  $(p - P_0) A + W(v_j - V)/g$ .

### EFFECT OF AFTER BURNING ON ENGINE THRUST

At take-off conditions, the momentum drag of the air flowing through the engine is negligible, so that the gross thrust can be considered to be equal to the net thrust. If after burning is selected, an increase in takeoff thrust in the order of 30 per cent is possible with the pure jet engine and considerably more with the bypass engine. This augmentation of basic thrust is of greater advantage for certain specific operating requirements.

Under flight conditions, however, this advantage is even greater, since the momentum drag is the same with or without after burning and, due to the ram effect, better utilization is done of every pound of air pumped through the engine.

Assuming an aircraft speed of 600 m.p.h. (880 ft.per sec.), then,  
 momentum drag  $\frac{880}{32.2} = 27.5$  lb. (approximately).

This means that every pound of air per second pumped through the engine and accelerated up to the speed of the aircraft caused a drag of about 27.5 lb.

Suppose each pound of air pumped through the engine gives a gross thrust of 77.5 lb. Then the net thrust given by the engine per lb. of air per second is  $77.5 - 27.5 = 50$  lb.

When after burning is selected, the gross thrust will be  $1.3 \times 77.5 = 107.5$  lb. Thus, under this condition, the net thrust per pound of air per second will be  $107.5 - 27.5 = 80$  lb. Therefore the ratio of net thrust due to after burning is  $80 = 1.60$ . In other words, a 30 per cent increase in thrust under static conditions becomes a 60 per cent increase in thrust at 600 m.p.h.

This larger increase in thrust is invaluable for obtaining higher speeds and higher altitude performance. The total and specific fuel consumption are high, but not unduly so for such an increase in performance.

The limit to the obtainable thrust is determined by the after burning temperature and the oxygen in the exhaust gas stream. Because no previous combustion heating takes place in the duct of a bypass engine, these engines with their large residual oxygen surplus are particularly suited to after burning and static thrust increases, of up to 70 per cent are obtainable. At high forward speeds several times this amount is achieved.

### EFFECT OF FORWARD SPEED

#### Ram Ratio

Ram ratio is the ratio of the total air pressure at the engine compressor entry to the static air pressure at the air intake entry.

### Mach Number

Mach number is an additional means of measuring speed and is defined as the ratio of the speed of a body to the local speed of sound. Mach 1.0 therefore represents a speed equal to the local speed of sound.

From the thrust equation

$$T = (p - P_0) A + W (v_j - V)$$

It is apparent that if the jet velocity remains constant, independent of aircraft speed, then as the aircraft speed increases the thrust would decrease in direct proportion. However, due to the 'ram ratio' effect from the aircraft forward speed, extra air is taken into the engine so that the mass airflow and also the jet velocity increase with aircraft speed. The effect of this tends to offset the extra intake momentum drag due to the forward speed so that the resultant net thrust is partially recovered as the aircraft speed increases. A typical trend curve illustrating this point is shown in fig.27. Obviously, the 'ram ratio' effect, or the return obtained in terms of pressure rise at entry to the compressor in exchange for the unavoidable intake drag, is of considerable importance to the turbojet engine, especially at high speeds. Above speeds of Mach 1.0 and as a result of the formation of shock waves at the air intake, this rate of pressure rise will rapidly decrease unless a suitably designed air intake is provided with an efficient air intake, ram ratio effect at supersonic speeds can be significantly increased.

As aircraft speed increases into the supersonic region, the ram air temperature rapidly rises consistent with the basic gas laws. This temperature rise effects the compressor delivery air temperature proportionately and, in consequence, to maintain the required thrust, the engine must be subjected to higher turbine entry temperature. Since the maximum permissible turbine entry temperature is determined by the temperature limitations of the turbine materials and the cooling techniques of blades and stators are increasingly involved.

With an increase in forward speed, the increased mass airflow due to the 'ram ratio' effect must be matched by the fuel flow and the result is an increase in fuel consumption. Because the net thrust tends to decrease with forward speed the end result is an increase in specific fuel consumption, as shown by the trend curves for a typical turbojet engine.

At forward speeds at low altitudes the 'ram ratio' effect causes very high stresses on the engine and, to prevent over stressing, the fuel flow is automatically reduced to limit the engine speed and airflow.

In the case of turboprop engine, the net jet thrust decreases, s.h.p. increases due to the 'ram ratio' effect of increased mass flow and matching fuel flow. Because it is standard practice to express the s.f.c. of a turbo-propeller engine relative to s.h.p. an improved s.f.c. is exhibited. However, this does not provide a true comparison with the curves, for a typically turbojet engine, as s.h.p. is absorbed by the propeller and converted into thrust and, irrespective of an increase in s.h.p., propeller efficiency and therefore, net thrust deteriorates at high subsonic forward speeds. In consequence, the turbo-propeller engine s.f.c. relative to net thrust would, in general comparison with the turbojet engine, show an improvement at low forward speeds but a rapid deterioration at high speeds.

### EFFECT OF ALTITUDE

With increasing altitude the ambient air pressure and temperature are reduced. This affects the engine in two interrelated ways :

The fall in pressure reduces the air density and hence the mass airflow into the engine for a given engine speed. This causes the thrust or s.h.p to fall. The fuel control system adjusts the pump output to match the reduced mass airflow, so maintaining a constant engine speed.

The fall in air temperature increases the density of the air, so that the mass of air entering the compressor for a given engine speed is greater. This causes the mass airflow to reduce at a lower rate and so compensates to some extent for the loss of thrust due to the fall in atmospheric pressure.

### EFFECT OF CLIMATE

On a cold day the density of the air increases so that the mass of air entering the compressor for a given engine speed is greater, hence the thrust or s.h.p is higher. The denser air does, however, increase the power required to drive the compressor or compressors; thus the engine will require more fuel to maintain the same engine speed or will run at a reduced engine speed if no increase in fuel is available.

On a hot day the density of the air decreases, thus reducing the mass of air entering the compressor and, consequently, the thrust of the engine for a given r.p.m. Because less power will be required to drive the compressor,

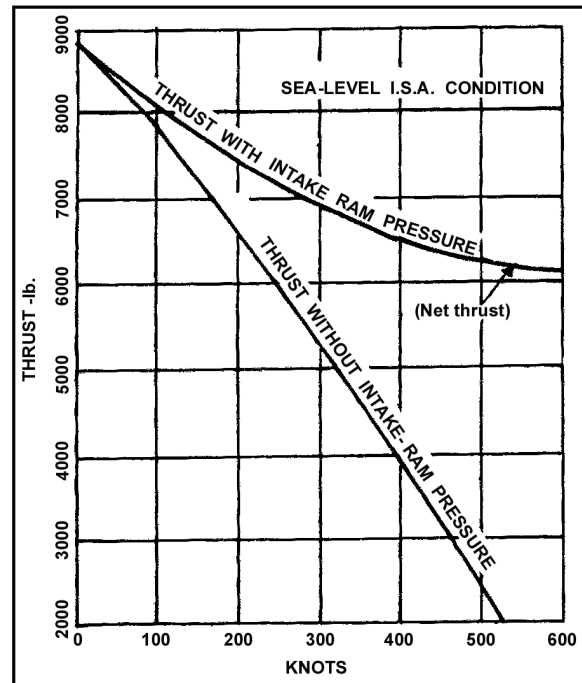

Fig. 1.35.

the fuel control system reduces temperature, as appropriate; however, because of the decrease in air density, the thrust will be lower. Some sort of thrust augmentation, such as water injection are sometimes used.

### PROPULSIVE EFFICIENCY

Performance of the jet engine is not only concerned with the thrust produced, but also with the efficient conversion of the heat energy of the fuel into kinetic energy, as represented by the jet velocity, and the best use of this velocity to propel the aircraft forward, i.e. the efficiency of the propulsive system. A turbo-propeller engine gives a small acceleration to a large mass of air, whereas a pure turbojet gives a large acceleration to a small mass of air.

The efficiency of conversion of fuel energy to kinetic energy is termed the thermal or internal efficiency and, like all heat engines, is controlled by the cycle pressure ratio and combustion temperature.

The efficiency of conversion of kinetic energy to propulsive work is termed the propulsive or external efficiency and this is affected by the amount of kinetic energy wasted by the propelling mechanism. Waste energy displaced in the jet wake, which represents a loss, can be expressed as  $(\frac{1}{2} m v^2)/g$  where  $V$  is the waste velocity ( $v_j - V$ ). It is therefore, apparent that at the aircraft lower speed range the pure jet stream wastes considerably more energy than a propeller system and consequently is less efficient over this range. However, this factor changes as aircraft speed increases, because although the jet stream continues to issue at a high velocity from the engine its velocity relative to the surrounding atmosphere is reduced and, in consequence, the waste energy loss is reduced.

Briefly, propulsive efficiency may be expressed as:

$$\eta_{\text{Propulsive}} = \frac{\text{work done on the aircraft}}{\text{Energy imparted to engine airflow}} \quad \text{or simply}$$

$$\eta_{\text{Propulsive}} = \frac{\text{work done}}{\text{Work done} + \text{work wasted in exhaust}}$$

Work done is the net thrust multiplied by the aircraft speed.

Propulsive efficiency =

$$\frac{[v \{ (p-p_0) A + w (v_j - v)/g \}]}{[v \{ (p-p_0) A + w (v_j - v)/g \} + \{ \frac{1}{2} w (v_j - v)^2 /g \}]}$$

In the instance of an engine operating with a non choked nozzle the equation become :

$$\frac{[WV (v_j - v)]}{[WV (v_j - v) + \frac{1}{2} (v_j - v)^2]} \quad \text{Simplified to: } \frac{2v}{V + v_j}$$

e.g. assuming an aircraft speed ( $V$ ) of 375 m.p.h. and a jet velocity ( $v_j$ ) of 1,230 m.p.h. the efficiency of a turbojet is:

$$\eta = \frac{2 \times 375}{375 + 1,250} = \text{approx 47 per cent}$$

On the other hand, at an aircraft speed of 600 m.p.h. the efficiency is :

$$\eta = \frac{2 \times 600}{600 + 1230} = \text{approx 66 per cent.}$$

propeller efficiency at these values of  $V$  is approximately 82 and 55 percent.

The disadvantage of the propeller at the higher aircraft speeds is its rapid fall off in efficiency, due to shock waves created around the propeller as the blade tip speed approaches Mach 1.0.

To obtain good propulsive efficiency without the use of a complex propeller system, the bypass principle is now used in various forms. With this principle, some part of the total output is provided by a jet stream other than that which passes through the engine cycle and this is energized by a fan or a varying number of L.P. compressor stages. This bypass air is used to lower the main jet temperature and velocity either by exhausting through a separate propelling nozzle, or by mixing with the turbine stream to exhaust through a common nozzle.

The propulsive efficiency equation for a high bypass ratio engine exhausting through separate nozzles is given below, where  $W_1$  and  $v_{j1}$  relate to the bypass function and  $W_2$  and  $v_{j2}$  to the engine main function.

$$\text{Propulsive efficiency} = \frac{[W_1 V (v_{j1} - v) + W_2 V (v_{j2} - v)]}{[W_1 V (v_{j1} - v) + W_2 V (v_{j2} - v) + \frac{1}{2} W_1 (v_{j1} - V)^2 + \frac{1}{2} W_2 (v_{j2} - v)^2]}$$

A graph illustrating the various propulsive efficiency with aircraft speed is shown in fig. 28.

### FUEL CONSUMPTION AND POWER-TO-WEIGHT RELATIONSHIP

Primary engine design considerations, particularly for commercial transport duty, are those of low specific fuel consumption and weight. Considerable improvement has been achieved by use of the bypass principle, and by advanced mechanical and aerodynamic features, and the use of improved materials. With the trend towards higher bypass ratios, in the range of 5:1, the triple-spool engine enables the pressure and bypass ratios to be achieved with short rotors, using fewer compressor stages, resulting in a lighter and more compact engine.

S.f.c. is directly related to the thermal and propulsive efficiency; that is, the overall of the engine. Theoretically, to provide a high thermal efficiency only a high pressure ratio is required, although in practice normal inefficiencies in the compression and expansion processes also necessitate a high turbine entry temperatures. In a pure turbojet engine this increase in temperature would increase the jet velocity and consequently lower the propulsive efficiency. However, by using the bypass principle, high thermal and propulsive efficiency can be effectively combined by bypassing a proportion of the L.P. compressor or fan delivery air to lower the mean jet temperature and velocity. With advanced technology engines of high bypass and overall pressure ratios, a further pronounced improvement in s.f.c. is obtained.

The turbines of the pure jet engine are heavy because they deal with the total airflow, whereas the turbines of the bypass engine deal only with part of the flow; thus the H.P. compressor, combustion chambers and turbines, can be



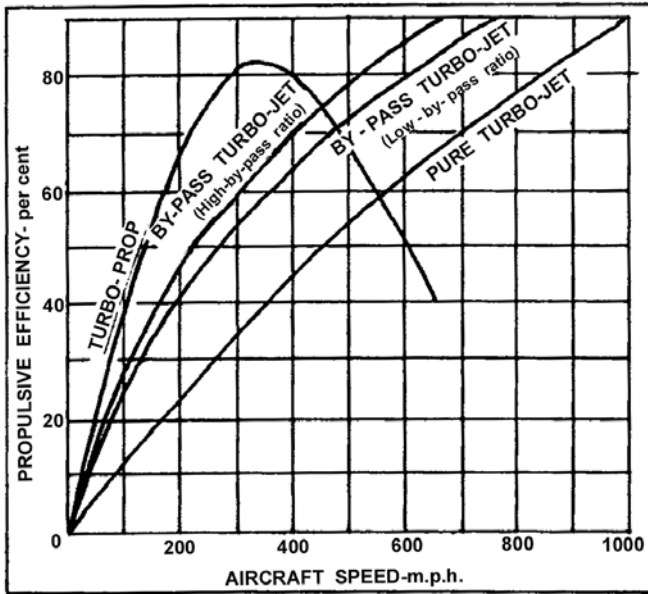

Fig. 1.36. Propulsive efficiencies and aircraft speeds.

reduced size of the H.P. section of the engine. There, in addition to the reduced specific fuel consumption, an improvement in the power-to-weight ratio is obtained.

### BRAYTON CYCLE

A simple gas turbine power plant is shown in fig.29. Air is first compressed adiabatically in process a-b, it then enters the combustion chamber where fuel is injected and burned essentially at constant pressure in process b-c, and then the products of combustion expand in the turbine to the ambient pressure in process c-d and are thrown out to the surroundings. The cycle is open. The state diagram on the p-v coordinates is shown in fig.

The Brayton cycle is the air standard cycle for the gas turbine power plant. Here air is first compressed reversibly and adiabatically, heat is added to it reversibly at constant pressure, air expands in the turbine reversibly and adiabatically and heat is then rejected from the air reversibly at constant pressure to bring it to the initial state. The Brayton cycle, therefore, consists of

Two reversible isobars and two reversible adiabatics.

The flow, p-v, and T-s diagrams are shown in fig below for m kg of air.

$$Q_1 = \text{heat supplied} = mc_p(T_3 - T_2)$$

$$Q_2 = \text{heat rejected} = mc_p(T_4 - T_1)$$

$$\text{Therefore Cycle efficiency} = 1 - Q_2/Q_1 = [1 - \{(T_4 - T_1)/(T_3 - T_2)\}]$$

$$\text{Now } T_2/T_1 = (p_2/p_1)^{(\gamma-1)/\gamma} = T_3/T_4 \quad (\text{Since } p_2 = p_3 \text{ and } p_4 = p_1)$$

$$[(T_4/T_1) - 1] = [(T_3/T_2) - 1]$$

$$\text{or } [(T_4 - T_1)/(T_3 - T_2)] = [T_1/T_2] = (p_1/p_2)^{\gamma-1/\gamma} = (v_2/v_1)^{\gamma-1}$$

if  $r_k$  = compression ratio =  $v_1/v_2$ , the efficiency becomes

$$\eta = 1 - (v_2/v_1)^{\gamma-1}$$

$$\text{or } \eta_{\text{brayton}} = 1 - 1/r_k^{\gamma-1}$$

if  $r_p$  = pressure ratio =  $p_2/p_1$  the efficiency may be expressed in the following form also

$$\eta = 1 - (p_1/p_2)^{(\gamma-1)/\gamma}$$

$$\text{or } \eta_{\text{brayton}} = 1 - 1/(r_p)^{(\gamma-1)/\gamma}$$

The efficiency of the Brayton cycle, therefore, depends upon either the compression ratio or the pressure ratio. For the same compression ratio, the Brayton cycle efficiency is equal to the Otto cycle efficiency.

### COMPARISON BETWEEN BRAYTON CYCLE AND OTTO CYCLE

Brayton and Otto cycles are shown superimposed on the p-v and T-s diagrams. For the same  $r_k$  and work capacity, the Brayton cycle (1-2-5-6) handles a larger range of volume and a similar range of pressure and temperature than does the Otto cycle (1-2-3-4).

scaled down. The increased power per lb. of air at the turbines, to take advantage of their full capacity, is obtained by the increase in pressure ratio and turbine entry temperature. It is clear that the bypass engine is lighter, because not only has the diameter of the pressure rotating assemblies been reduced but the engine is shorter for a given power output. With a low bypass ratio engine, the weight reduction compared with a pure jet engine is in the order of 20 per cent for the same air mass flow.

With a high bypass ratio engine of the triple spool configuration, a further significant improvement in specific weight is obtained. This is derived mainly from advanced mechanical and aerodynamic design, which, in addition to permitting a significant reduction in the total number of parts, enables rotating assemblies to be more effectively matched and to work closer to optimum conditions, thus minimizing the number of compressor and turbine stages for a given duty. The use of higher strength lightweight materials is also a contributory factor.

For a given mass flow, however, less thrust is produced by the bypass engine due to the lower exit velocity. Thus, to obtain the same thrust, the bypass engine must be scaled to pass a larger total mass airflow than the pure turbojet engine. The weight of the engine, however, is still less because of the

In the reciprocating engine field, the Brayton cycle is not suitable. A reciprocating engine cannot efficiently handle a large volume flow of low pressure gas, for which the engine size  $\pi/4 D^2L$  becomes large, and the friction losses also become more. So the Otto cycle is more suitable in the reciprocating engine field.

In turbine plants, however, the Brayton cycle is more suitable than the Otto cycle. An internal combustion engine is expressed to the highest temperature (after the combustion of fuel) only for a short while, and it gets time to become cool in the other processes of the cycle. On the other hand, a gas turbine plant, a steady flow device, is always exposed to the highest temperature used. So to protect material, the maximum temperature of gas that can be used in a gas turbine plant cannot be as high as in an internal combustion engine. Also, in the steady flow machinery, it is more difficult to carry out heat transfer at constant volume than at constant pressure. Moreover, a gas turbine can handle a large volume flow of gas quite efficiently. So we find that the Brayton cycle is the basic air standard cycle for all modern gas turbine plants.

**ROCKET ENGINES**

A rocket is a reaction engine used for thrust buildup, energy source and working medium source installed on the vehicle to be propelled.

The main advantage of the rocket engine over the air-breathing jet engine is its ability to work and develop thrust at any speed and at any flight altitude. Rocket engine thrust remains constant during a change in flight velocity and is little affected by the altitude of the flight.

The rocket engine is usually used in aviation as an auxiliary engine for different types of aircraft. It is widely used in rocket technology and is the basic type of engine in modern cosmonautics.

At the present time heat rocket engines are used in aviation, rocket technology and cosmonautics, using the chemical energy of a liquid or solid propellant. In the first case the engine is called liquid-propellant rocket engine, in the second a solid-propellant rocket engine.

**LIQUID-PROPELLANT ROCKET ENGINE & SOLID-PROPELLANT ROCKET ENGINE**

The main element of the liquid-propellant rocket engine is the chamber, consisting of head, combustion chamber, nozzle, cooling jacket and flame igniter (device for ignition).

In the chamber there takes place combustion of the propellant being fed into it (with the aid of a pump or pressure feed system) from tanks and considerable part of the enthalpy of the combustion products is converted into kinetic energy.

During the expansion of the combustion products in the nozzle the pressure is lowered and the speed substantially increases. With gas velocity increase at the nozzle exit and economy of the engine improves. The greater the velocity and the mass of gas exiting from the nozzle per unit of time the higher the thrust of the liquid-propellant rocket engine.

To obtain a high velocity of combustion products at the nozzle exit a propellant is required to possess large calorific value and a considerable effective pressure ratio in the nozzle. Therefore, in the combustion chamber a fairly high pressure is maintained. The engine operates on a propellant consisting of liquid oxygen (oxidizer) and hydrocarbon fuel.

In liquid-propellant rocket engines we frequently use a hydrocarbon fuel as kerosene. More effective is hydrogen, which in burning liberates almost three times the heat from the same quantity of kerosene by weight.

For engines that operate on a propellant consisting of liquid oxygen and liquid hydrogen the gas velocity at the nozzle exit in flight at a great distance from the earth reaches approximately 4.2 to 4.4 km/sec.

As for the aircraft gas turbine engine, or a liquid-propellant rocket engine, during operation a flame igniter is not required. The flame in the combustion chamber created when starting the engine is maintained by a continuous feed of propellant components into the chamber. To light a flame for starting we use a pyrotechnic or electric flame igniter and other means.

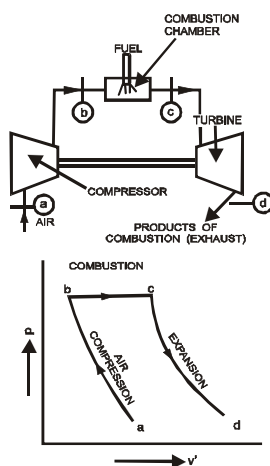

Fig. 1.37.

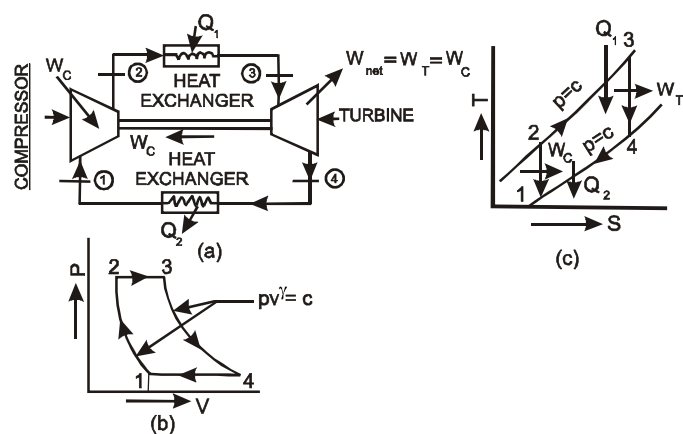

Fig. 1.38.

Some liquid-propellant rocket engine, including some space engines, operate on a hypergolic propellant, i.e. on a propellant that ignites on contact between oxidizer and fuel is a result of the chemical reaction developed by their interaction. In this case a flame igniter is not required.

Cooling of the engine chamber, necessary because of the high temperature of the combustion products (3,000°C and above), is usually achieved with the aid of one of the propellant components. It first cools the chamber walls from the outside and then enters the combustion chamber through the head. Frequently the chamber walls cool not only from the outside but also from the inside. For this we lower the temperature of the layer of combustion products near the wall by same means or other. Some other methods of cooling the engine chamber are also used.

The main elements of solid-propellant rocket engine are combustion chambers, the propellant charge 3 placed in it, nozzle 2 and igniter 4.

The construction of a solid-propellant rocket engine and its maintenance during operation and storage are simpler than for liquid-propellant rocket engines. Its special advantage is constant readiness for operation and simplicity of starting. By Comparison with the liquid-propellant rocket engine the solid-propellant rocket engine makes possible a big reduction in the time needed to prepare the rocket for starting. It allows storage of rockets charged with propellant and ready for launching for a long time and at the same time considerably lowers the cost.

The main disadvantages of the solid-propellant rocket engine are a lower specific thrust by comparison with the liquid-propellant rocket engine and also severe difficulties in control of the engine thrust value. The specific thrust (or specific impulse) of a rocket engine using chemical propellant is consumption per second.

Of great interest is the sectional solid-propellant rocket engine. It consists of parts (sections) separately manufactured, controlled and transported to the launching pad.

The front (nose) section is the front part of the combustion chamber of the engine, the rear (tail) section terminates with a jet nozzle, and the intermediate standard sections are interchangeable.

The engine can be assembled for the front, rear and a variable number of intermediate sections, which makes it possible in a simple way to change the total (sum) impulse of the engine and parameters of the flight vehicle within wide limits, for example the range or payload.

The total impulse of a solid-propellant rocket engine is the product of the average thrust (during the engine's operating time) it develops and the time of operation of the engine, corresponding to complete burn-up of the propellant charge.

Liquid-propellant rocket engines and solid-propellant rocket engines are able to develop very high thrust force with low weight and small overall size. Under terrestrial static conditions and especially in flight at altitudes over 10 to 20 km the specific weight of these engine is many times less than for a turbojet engine.

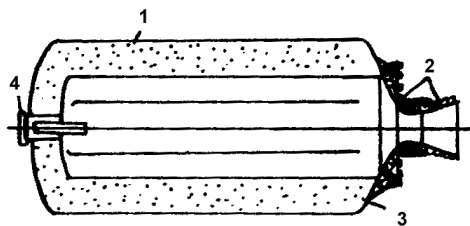

Fig. 1.41. Solid Propellant Rocket.

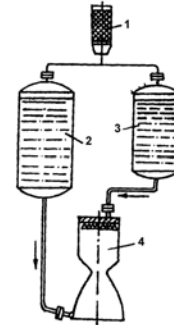

Fig. 1.39.

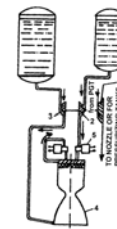

Fig. 1.40.

They have great advantages over the turbojet engine with respect of the thrust being developed in one unit, its invariability with change in flight speed, small change during climb and lightness and small size. However, their service life is such shorter and the fuel economy at the speeds and altitudes of contemporary aviation is much worse than for turbojet engine.



# CHAPTER - 2

## STARTING AND IGNITION SYSTEMS

### (TURBINE ENGINES)

#### INTRODUCTION

Two separate systems are required to start a turbine engine, a means to rotate the compressor turbine assembly and a method of igniting the air/fuel mixture in combustion chamber. Ideally the process is automatic after the fuel supply is turned on and the starting circuit brought into operation.

#### METHODS OF STARTING

The starting procedure for all jet engines is basically the same, but can be achieved by various methods. The type and power source for the starter varies in accordance with engine and aircraft requirements. Some use electrical power, others use gas, air, or hydraulic pressure, and each has its own merits. For example, a military aircraft requires the engine to be started in the minimum time and, when possible to be completely independent of external equipment. A commercial aircraft, however, requires the engine to be started with the minimum disturbance to the passengers and by the most economical means.

The starter motor must produce a high torque and transmit it to the engine rotating assembly in a manner that provides smooth acceleration from rest upto a speed at which the gas flow through the engine provides sufficient power for the engine turbine to take over.

#### Electric

Electric starting is used on some turboprop and turbojet engines. The starter is usually a direct current (D.C.) electric motor coupled to the engine through a reduction gear and ratchet mechanism or clutch, which automatically disengages after the engine has reached a self-sustaining speed.

The electrical supply may be of a low or high voltage, and it is passed through a system of relays and resistance to allow the full voltage to be progressively built up as the starter gains speed. It also provides the power for operation of the ignition system. The electrical supply is automatically cancelled when the starter load is reduced after the engine has satisfactorily started or when the time cycle is completed.

#### Cartridge

Cartridge starting is sometimes used on military engines and provides a quick independent method of starting. The starter motor is basically a small impulse-type turbine that is driven by high velocity gases from a burning cartridge. The power output of the turbine is passed through a reduction gear, and an automatic disconnect mechanism to rotate the engine. An electrically fired detonator initiates the burning of the cartridge charge. As a cartridge charge provides the power supply for this type of starter, the size of the charge required may well limit the use of cartridge starters.

#### Iso-Propyl Nitrate

Iso-propyl-nitrate starting provides a high power output and gives rapid starting characteristics, but is dependent upon supplies of iso-propyl-nitrate.

This starter motor also has a turbine that transmits power through a reduction gear to the engine. In this instance, the turbine is rotated by high pressure gasses resulting from the combustion of iso-propyl-nitrate. This fuel is mono-fuel i.e., it requires no air to sustain combustion. The fuel is sprayed into a combustion chamber which forms part of the starter, where it is electrically ignited by a high-energy ignition system. A pump supplies the fuel to the combustion chamber from a storage tank, and an air pump scavenges the combustion chamber of fumes before each start. Operation of the fuel and air pumps, ignition systems, and cycle cancellation, is electrically controlled by relays and time switches.

#### Air Starter

Air starting is used on most modern commercial and some military jet engines. It has many advantages over other starting systems, as it is comparatively light, simple and economical to operate.

An air starter motor has a turbine rotor that transmits power through a reduction gear and clutch to the starter output shaft that is connected to the engine.

The starter turbine is rotated by air pressure taken from an external ground supply, from an auxiliary power unit (A.P.U.) carried in the aircraft, or from an engine that is running. The air supply to the starter is controlled by an electrically operated control and pressure reducing valve that is opened when an engine start is selected and is automatically closed at a predetermined starter speed. The clutch also automatically disengages as the engine accelerates upto idling r.p.m. and the rotation of the starter ceases.

A combustion starter is sometimes fitted to an engine incorporating an air starter, and is used to supply power to the starter when an external supply of air is not available. The starter unit has a small combustion chamber into which high pressure air, from an aircraft-mounted storage bottle, and fuel, from the engine fuel system, are introduced. Control valves regulate the air supply, which pressurizes a fuel accumulator, to give sufficient fuel pressure for atomization, and also activates the continuous ignition system. The fuel/air mixture is ignited in the combustion chamber, and the resultant gas is directed on to the turbine of the air starter. An electrical circuit is provided to shut off the air supply, which in turn terminates the fuel and ignition systems on completion of the starting cycle.

Some turbojet engines are not fitted with starter motors, but use air impingement onto the turbine blades as a means of rotating the engine. The high pressure air is obtained from an external source or from an engine that is running, and is directed, through non-return valves and nozzles, onto the turbine blades.

### **Gas Turbine**

A gas turbine starter is used for some jet engines and is completely self-contained. It has its own fuel and ignition system, starting system (usually electric or hydraulic) and self-contained oil system. This type of starter is economical to operate and provides a high power output for a comparatively low weight.

The starter consists of a small, compact gas turbine engine, usually featuring a turbine-driven centrifugal compressor, a reverse flow combustion system, and a mechanically independent free-power turbine. The free-power turbine is connected to the main engine via a two-stage epicyclic reduction gear, automatic clutch and output shaft.

On initiation of the starting cycle, the gas turbine starter is rotated by its own starter motor unit it reaches self-sustaining speed, when the starting and ignition systems are automatically switched off. Acceleration then continues up to a controlled speed of approximately 60,000 r.p.m. At the same time as the gas turbine starter engine is accelerating, the exhaust gas is being directed, via nozzle guide vanes, onto the free turbine to provide the drive to the main engine. Once the main engine reaches self-sustaining speed, a cutout switch operates and shuts down the gas turbine starter. As the starter runs down, the clutch automatically disengages from the output shaft, and the main engine accelerates up to idling r.p.m. under its own power.

### **Hydraulic**

Hydraulic starting is used for starting some small jet engines. In most applications, one of the engine-mounted hydraulic pumps is utilized and is known as a pump/starter, although other applications may use a separate hydraulic motor. Methods of transmitting the torque to the engine may vary, but a typical system would be a reduction gear and clutch assembly. Power to rotate the pump/starter is provided by hydraulic pressure from a ground supply unit, and is transmitted to the engine through the reduction gear and clutch. The starting system is controlled by an electrical circuit that also operates hydraulic valves so that on completion of the starting cycle the pump/starter functions as a normal hydraulic pump.

### **IGNITION OF THE JET ENGINES**

The ignition system of a turbine engine must provide the electrical discharge necessary to ignite the air/fuel mixture in the combustion chamber during starting and must also be capable of operating independently from the starter system in the event of flame extinction through adverse flight conditions. (fig 2.1)

The electrical energy required to ensure ignition of the mixture varies with atmospheric and flight conditions, more power being required as altitude increases. However, under certain flight conditions, such as icing or take off in heavy rain or snow, it may be necessary to have the ignition system continuously operating to give an automatic relight should flame extinction occur. For this conditions, a low volt output (e.g. 3 to 6) is favourable because it results in longer life of the ignition plug and ignition unit. Two independent 12 joule systems are normally fitted to each engine to provide a positive light up during starting but some engines have now 12 joule and 3 joule system. The 3 joule system is kept in continuous operation to provide automatic relighting.

Where continuous operation of one system is not desirable, a glow plug is sometimes fitted in the combustion chamber where it is heated by the combustion process and remains incandescent for a sufficient period of time to ensure automatic re-ignition.

### **HIGH ENERGY IGNITION UNIT**

A 12 joule unit receives electrical power from the aircraft d.c. supply either in conjunction with starter operation or independently through the "relight" circuit. An induction coil or transistorized H.T. generator repeatedly charges a capacitor in the unit until the capacitor voltage is sufficient to break down a sealed discharge gap. The discharge is conducted through a choke and H.T. lead to the igniter plug where the energy is released in a flashover on the semi-conducting face of the plug. The capacitor is then recharged and the cycle repeated approximately twice every second. A resistor connected from the output to earth ensures that the energy stored in the capacitor is discharged when the d.c. supply is disconnected.

NOTE: A 3 joule unit is usually supplied with LT alternating current but its function is similar to that described above.

The electrical energy stores in the high energy ignition unit is potentially lethal and even though the capacitor is discharged when the d.c. supply is disconnected, certain precautions are necessary before handling the components. The associated circuit breaker should be tripped, or fuse removed as appropriate, and at least one minute allowed to elapse before touching the ignition unit, high tension lead or igniter plug.

Ignition units are attached to the aircraft structure by anti-vibration mounting and the rubber bushes should be checked for perishing at frequent intervals. It is also important that the bonding cable is securely attached, making good electrical contact and of sufficient length to allow for movement of the unit on its mounting.

At the intervals specified in the appropriate Maintenance Schedule the unit should be inspected for signs of damage, cracks or corrosion. Bonding leads securely attached and locked.

### **IGNITER PLUG**

The igniter plug consists of a central electrode and outer body, the space between them being filled with an insulating material and terminating at the firing end in a semi-conducting pellet. A spring-loaded contact button is fitted at the outer end of the electrode. During operation a small electrical leakage from the ignition unit is fed through the electrode

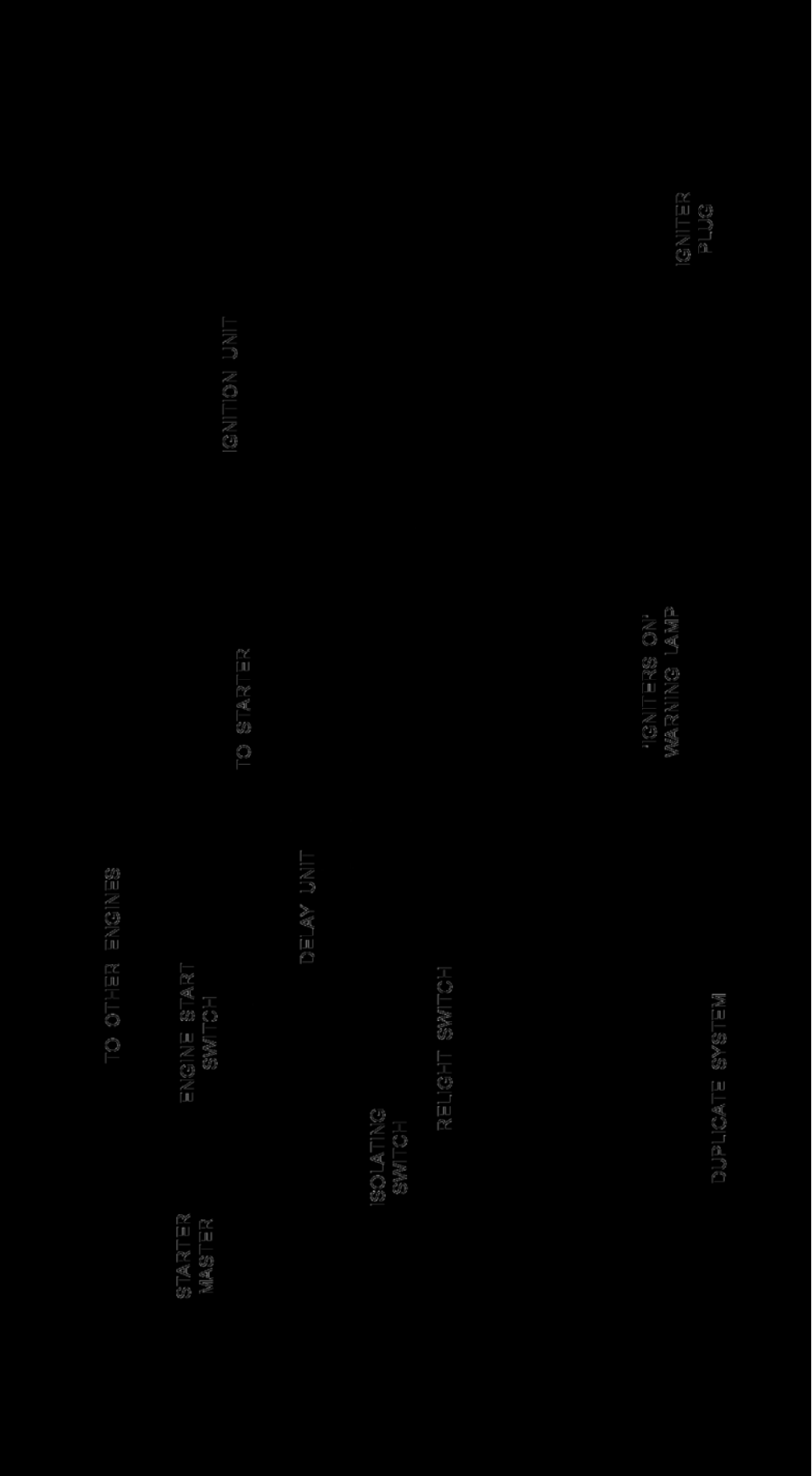

Fig. 2.1. Typical ignition system.

to the plug body and produces an ionized path across the surface of the pellet. The high intensity discharge takes place across this low-resistance path.

### IGNITION LEAD

The high energy ignition lead is used to carry the intermittent high voltage outputs from the ignition unit to the associated igniter plug. A single insulated core is encased in a flexible metal sheath and terminates in a spring-loaded contact button at each end. The end fittings usually incorporate a self locking attachment nut.

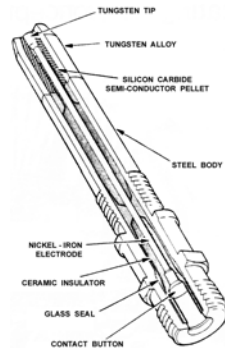

Fig. 2.2. Igniter Plug.

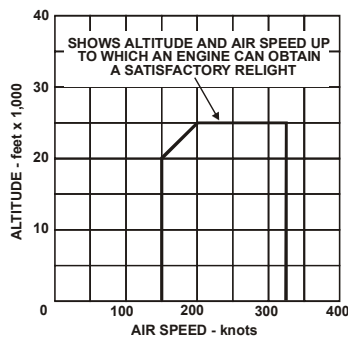

Fig. 2.3. A typical flight relight envelope.

### SEQUENCE OF STARTING OF A GAS TURBINE ENGINE

#### GROUND RUNNING

The life of a turbine engine is affected both by the number of temperature cycles to which it is subjected and by operation in a dusty or polluted atmosphere. Engine running on the ground should therefore be confined to the following occasions:

- After engine installation.
- To confirm a reported engine fault.
- To check an aircraft system.
- To prove an adjustment or component change.
- To prove the engine installation after a period of idleness.

#### Safety Precautions

Turbine engines ingest large quantities of air and eject gases at high temperature and high velocity, creating danger zones both in front of and behind the aircraft. The extent of these danger zones varies considerably with engine size and location and this information is given in the appropriate aircraft Maintenance Manual. The danger zones should be kept clear of personnel, loose debris and equipment whenever the engines are run. The aircraft should be positioned facing into wind so that the engine intakes and exhausts are over firm concrete with the jet efflux directed away from other aircraft and buildings. Silencers or blast fences should be used whenever possible for runs above idling power. Additional precautions, such as protective steel plates or deflectors, may be required when testing thrust reversers or jet lift engines, in order to prevent ground erosion.

Air intakes and jet pipes should be inspected for loose articles and debris before starting the engine and the aircraft main wheels chocked fore and aft. It may be necessary to tether vertical lift aircraft if a high power check is to be carried out.

Usually on large aircraft one member of the ground crew is stationed outside the aircraft and provided with a radio headset connected to the aircraft intercom system. This crew member is in direct communication with the flight deck and able to provide information and if necessary warnings on situations not visible from inside the aircraft. Due to the high noise level of turbine engines running at maximum power, it is advisable for other ground crew members to wear ear muffs.

### RELIGHTING

The jet engine requires facilities for relighting should the flame in the combustion system be extinguished during flight. However, the ability of the engine to relight will vary according to the altitude and forward speed of the aircraft. A typical relight envelope, showing the flight conditions under which an engine will obtain a satisfactory relight, is shown in Fig. 2.3. Within the limits of the envelope, the airflow through the engine will rotate the compressor at a speed satisfactory for relighting; all that is required therefore, provided that a fuel supply is available, is the operation of the ignition system. This is provided for by a separate switch that operates only the ignition system.

A suitable CO<sub>2</sub> or foam fire extinguisher must be located adjacent to the engine during all ground runs. The aircraft fire extinguishing system should only be used in the event of a fire in an engine which is fully cowled.

### Starting

There are many different types of turbine engine starters and starting systems, therefore it is not possible to give a sequence of operations exactly suited to all aircraft. The main requirements for starting are detailed in the following paragraphs.

An external electrical power supply is often required and should be connected before starting. Where a ground/flight switch is provided this must be set to 'ground' and all warning lights checked for correct operation.

Where an air supply is required for starting this should be connected and the pressure checked as being sufficient to ensure a start.

NOTE: If the electrical and air supplies are not adequate for starting purposes it is possible for a light-up to occur at insufficient speed for the engine to accelerate under its own power. This could result in excessive turbine temperatures and damage to the engine.

The controls and switches should be set for engine starting, a check made to ensure that the area both in front of and behind the engine is clear and the starter engaged. When turbine rotation becomes apparent the HP cock should be opened and the engine instruments monitored to ensure that the starting cycle is normal. When light-up occurs and the engine begins to accelerate under its own power, switch off the starter. If it appears from the rate of increase in exhaust or turbine gas temperature that starting limits will be exceeded the HP cock should be closed immediately and the cause investigated (see under 'Trouble Shooting' in the appropriate Maintenance Manual).

Once engine speed has stabilised at idling, a check should be made that all warning lights are out, the external power supplies disconnected and the ground/flight switch moved to 'flight'.

### Testing

When a new engine has been installed a full ground test is necessary, but on other occasions only those parts of the test necessary to satisfy the purpose of the run need be carried out. The test should be as brief as possible and for this reason the aircraft Maintenance Manual specifies a sequence of operations which should always be observed. Records of the instrument readings obtained during each test should be kept to provide a basis for comparison when future engine runs become necessary.

Each aircraft system associated with engine operation should be operated and any warning devices or indicators in the cockpit checked against physical functioning. It may be necessary in certain atmospheric conditions to select engine anti-icing throughout the run and this should be ascertained from the minimum conditions quoted in the Maintenance Manual.

The particular tests related to engine operation are idling speed, maximum speed, acceleration, and function of any compressor airflow controls which may be fitted. Adjustments to correct slight errors in engine operation are provided on the engine fuel pump, flow control unit, and airflow control units. Observed results of the tests must be corrected for ambient pressure and temperature, tables or graphs being provided for this purpose in the aircraft Maintenance Manual. Adjustments may usually be carried out with the engine idling unless it is necessary to disconnect a control. In this case the engine must be stopped and a duplicate inspection of the control carried out before starting it again. An entry must be made in the engine log book quoting any adjustments made and the ambient conditions at the time.

### Stopping

After completion of the engine run the engine should be idled until temperatures stabilise and then the HP cock closed. The time taken for the engine to stop should be noted and compared with previous times, due allowance being made for wind velocity (e.g. a strong head wind will appreciably increase the run-down time). During the run-down fuel should be discharged from certain fuel component drains and this should be confirmed. A blocked drain pipe must be rectified. When the engine has stopped, all controls and switches used for the run must be turned off and the engine inspected for fuel, oil, fluid and gas leaks.

After a new engine has been tested the oil filters should be removed and inspected and after refitting these items the system should be replenished as necessary.





# CHAPTER - 3

## LUBRICATION SYSTEM : GAS TURBINE ENGINE

### INTRODUCTION

The lubrication requirements of an aircraft gas turbine engine are generally not too difficult to meet, because the oil does not lubricate any parts of the engine that are directly heated by combustion. Because of this, the loss of oil from the system is small compared with that from a piston engine.

The requirements of a turbo-propeller engine are a little more-severe than those of a turbojet engine, because of the heavily loaded propeller reduction gears and the need for a high pressure oil supply to operate the propeller pitch control mechanism.

Most gas turbine engines use a self-contained recirculatory oil system, in which the oil is distributed and returned to the oil tank by pumps. Some turbojet engines, however, use another system known as the total loss or expendable system in which the oil is spilled overboard after the engine has been lubricated. Recirculatory are divided into two types they are (i) Pressure Relief Valve (ii) Full flow systems, the major difference between them being in the control of the oil flow to the bearings.

### LUBRICATION SYSTEMS

#### Recirculatory system

##### Pressure relief valve system

In pressure relief valve system the oil flow to the bearings of the rotating assemblies is controlled by limiting the maximum pressure in the feed line. This is achieved by a system relief valve in which feed oil pressure is opposed by a spring pressure plus atmospheric pressure via the oil tank. On some installations bearing housing pressure or an equivalent of this is used in place of atmospheric pressure. Above a specific engine speed, feed oil pressure overcomes the opposing pressure and the excess oil spills back to the tank, thus maintaining the pressure and flow to the bearings constant at higher engine speeds.

##### Operation

The pressure pump draws the oil from the tank through strainer which protects the pump gears from any debris which may have entered the tank. Oil is then delivered through a pressure filter to a relief valve (system relief valve) that controls the maximum pressure of the oil flow to the rotating assemblies. On some engines an additional relief valve (pump relief valve) is fitted at the pressure pump out let. This valve is set to open at a much higher pressure than the system relief valve and opens only to return the oil to the inlet side of the pump should the system become blocked. To prevent oil starvation when the oil is very cold or the pressure filter is partially blocked, a bypass valve that operates at a preset pressure difference is fitted across the inlet and outlet of the pressure filter.

On the turbojet system the pressure oil from the relief valve is delivered, through transfer tubes and passages, to lubricate the bearings and gears. Twin-spool engines are provided with a separate metering pump that supplies a controlled amount of oil to the front bearing of the low pressure compressor. This prevents flooding during the initial stage of the starting cycle when only the high pressure compressor is rotating. As the low pressure compressor starts to rotate, oil is supplied to the front bearing, the flow being centred in relationship to compressor speed.

On the turbo-propeller system, the pressure oil is divided after leaving the relief valve, to feed the rotating assembly bearings, propeller pitch control supply system, reduction gear and torque-meter system.

The rotating assembly bearings and some of the heavier loaded gears in the gearboxes are lubricated by oil jets and these are often protected by thread-type filters. The remaining bearings and gears are splash lubricated. Bearings at 'hot' end of the engine receive the maximum oil flow because, in addition to lubricating the bearings, the oil assists in heat dissipation.

On some engines, to minimize the effect of the dynamic loads transmitted from the rotating assemblies to the bearing housing, 'squeeze film' type bearings are used. These have a small clearance between the outer track of the bearing and the housing, the space being filled with feed oil. The film modifies the radial motion of the rotating assembly and the dynamic loads transmitted to the bearing housing, thus reducing the vibration level of the engine and the possibility of damage by fatigue.

To prevent the flooding of the bearing housing, it is necessary to use more than one pump to return or scavenge it to the oil tank. This is achieved by using a pack of pumps, each of which returns the oil from a particular section of the engine. To protect the pump gears, each return pipe is provided with a strainer that, during inspection, can reveal the failure or impending failure of a component.

##### Centrifugal breather

To separate the air from the oil returning to the tank, a de-aerating device and a centrifugal breather are incorporated. The return air/oil mixture is fed on to the de-aerator where partial separation occurs, the remaining air/oil mist then passes into the centrifugal breather for final separation. The rotating vanes of the breather centrifuge the oil from the mist and the air is vented overboard through the hollow drive shaft.

### Oil coolers

On all engines using the recirculatory type of oil system, heat is transferred to the oil from the engine and it is, therefore, common practice to fit an oil cooler. The cooling medium may be fuel or air and, in some instances, both fuel-cooled and air-cooled coolers are used.

If fuel is used as a cooling medium, either low pressure or high pressure fuel may be used, for in both instances the fuel temperature is much lower than the oil temperature. Whether the cooler is located in the feed side or the return side of a lubrication system depends upon the operating temperature of the bearings.

A turbo-propeller engine may be fitted with an oil cooler that utilizes the external airflow as a cooling medium. This type of cooler, however, incurs a large drag factor and, as kinetic heating of the air occurs at high forward speeds, it is unsuitable for turbojet engines.

### Magnetic plugs

Magnetic plugs or chip detectors be fitted in the return oil side of a system to provide a warning of impending failure without having to remove and inspect the scavenge strainers. Some of these detectors are designed so that they can be removed for inspection without oil loss occurring; others may be checked externally by a lamp and battery or even connected to a crew compartment warning system to give an in-flight indication.

### FULL FLOW SYSTEM

The full flow system is different from a pressure relief valve system, in that the flow of oil to the bearings is determined by the speed of the pressure pump, the size of the oil jets and the pressure in each bearing housing. The system also

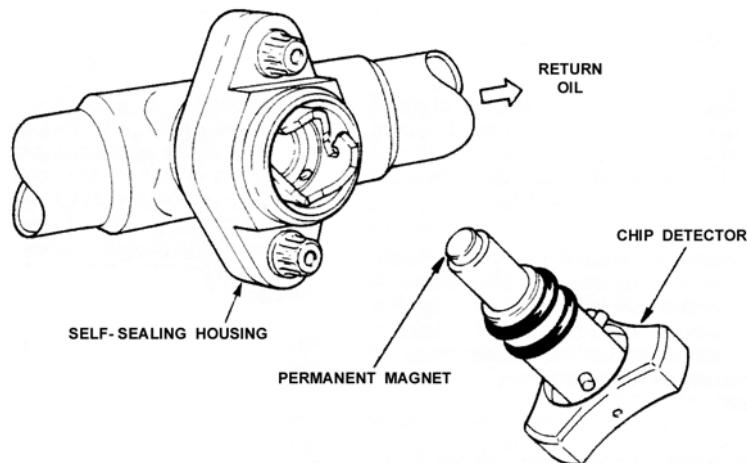

Fig. 3.1. A magnetic chip detector.

Magnetic chip detectors are also fitted in the return oil lines, and squeeze film bearings are used to reduce engine vibration; indications of pressure and temperature are also displayed in the crew compartment. On some engines an anti-syphon jet is provided to prevent oil in the feed line draining through the pressure pump into the gearbox when the engine is stationary, the oil being diverted into the oil tank.

### TOTAL LOSS (EXPENDABLE) SYSTEM

The total loss oil system is generally used only on engines that run for periods of short duration, such as vertical lift and booster engines. The system is simple and incurs low weight penalties, because it requires no oil cooler, scavenge pump or filters. On some engines oil is delivered in a continuous flow to the bearings by a plunger type pump, indirectly driven from the compressor shaft; on others it is delivered by a piston-type pump operated by fuel pressure. On the latter, the oil supply is automatically selected by the high pressure shut-off valve (cock) during engine starting and is delivered as a single shot to the front and rear bearings. On some engines provision is made for a second shot to be delivered to the rear bearing only, after a predetermined period.

After lubricating the fuel unit and front bearings, the oil from the front bearing drains into a collector tray and is then ejected into the main gas stream through an ejector nozzle. The oil that has passed through the rear bearing drains into a reservoir at the rear of the bearing where it is retained by centrifugal force until the engine is shut down. This oil then drains overboard through a central tube in the exhaust unit inner cone.

### TYPICAL LUBRICATION SYSTEM OF A TURBO FAN ENGINE: P & W JT 8D ENGINE

The JT8D gas turbine engine has a 'hot tank' system. The term refers to the technique of returning hot scavenged oil directly from bearing compartments to the de-aerator located in the oil tank.

In a cold tank system, the scavenged oil is passed through the oil cooler before being returns to oil tank. The advantage of 'hot tank' system is more efficient removal of entrapped air.

incorporates a metered spill of feed oil back to the tank and this spill, together with the oil jets, is calibrated to match the pump output. This arrangement ensures that the oil flow requirements of the bearings are met at all engine speeds. The function of the relief valve in the relief valve system to the open only to prevent excessive oil pressure occurring in the feed side of the system.

A pressure filter bypass valve is not normally fitted, but the pressure drop across either the filter or the system is sensed by a differential pressure switch. An increase in the pressure difference is shown on the indicating system, thus giving advance warning of a blocked filter.

The full flow system, like the pressure relief valve system, draws oil from a tank and delivers it in a similar way, via a pressure filter, to various parts of the engine from where it is returned by scavenge pumps, via oil coolers, to the tank. Likewise, air is separated from the oil by a de-aerator and centrifugal breather.

**Pressure system**

The oil is gravity fed from the tank to the main oil pump by a transfer tube and cored passage in the accessories gear box. Pump discharge pressure is then directed to main oil filter. A by pass valve provided in filter provides oil if main filter becomes obstructed.

External pressure taps are provided to sense before and after filter. This permits in-flight monitoring of main oil filter via a differential pressure switch and annunciator light on flight deck.

Oil from filter, regulated to provide operating pressure after the fuel oil cooler, directed to oil cooler and further delivered to engine bearings, components and accessories gear box at desired pressure and temperature.

Pressure regulated valve is located in a cored passage and regulate oil pressure. The surface area of oil cooler is adequate to provide sufficient cooling when flow is the mid to high range, thus, the thermostat control is eliminated. The higher oil temperature at prolonged idling can be controlled by moving the power lever to higher speed periodically.

**Secavange System**

After the oil has lubricated the engine and accessories box bearings, it is returned to oil tank by the secavange system.

The main collection points for secavanging oil located in the Numbers. 1,4,5,and 6 bearings compartment and accessories gear box. A gear type of pump is located in each compartment. Secavange oil from No.1 bearing is returned directly to gear box, number 2 and 3 secavange to gear box by gravity and breather flow throw tower shaft housing. Gear box lube oil along with the oil secavanged from 1,2 and 3 supports is returned to oil tank by gear box secavange pump.

Secavange oil from No.6 bearing area is pumped to no 4(1/2) bearing area through transfer tubes located in low pressure turbine shaft. Centrifugal force causes the oil to be ejected from the no 4(1/2) bearing out through the high pressure turbine shaft secavanging holes to No 4 and 5 bearing compartments. The secavange pump located in No.4 and 5 bearing compartment directly return the oil to the oil tank.

**Breather System**

To ensure proper oil flow and to maintain satisfactory secavange pump performance, the pressure in the bearing cavities is controlled by the breather system. The breather air from all the main bearings is vented to the accessory gear box as follows:-

- a. The No.1 bearing breather air is vented to the accessories box via external tubing.
- b. The No.2 and 3 bearings are vented internally to the accessory gear box through tower shaft housing.
- c. The No. 4(1/2) and 6 bearing breath through the secavange system into No. 4 and 5 collection point.
- d. The combined breather air from No. 4, 4(1/2), 5 and 6 bearings is vented to the accessory gear box through an external line. A de-oiler located in the accessory gear box serves to remove oil particles from in the breathing air before it is discharged into airframe waste tube.

Magnetic plugs and chip detectors are located in oil system to indicate the presence of metallic chips in lubricating oil in subsequence of any internal failure of bearings.

**TYPICAL LUBRICATION SYSTEM OF A TURBO PROPELLER ENGINE: ALLISON 501-D13**

For this engine, oil storage and cooling provisions are made in aircraft and provides independent oil supply for power section and reduction gear assembly.

**Power Section Lubrication System**

It contain an independent lubrication system with the exception of airframe furnished parts common to power section and reduction gear.

**Main Oil Pump**

It includes the pressure pump, a secavange pump and the pressure regulating valve

**Oil Filter**

It houses a check valve, filter element and the by pass valve for the filter is located in gear box housing.

**Three Secavange Pumps**

Located in diffuser, turbine inlet casing and turbine rear bearing support

**Secavange Relief Valve**

Located in the accessory drive housing assembly

**Breather**

Located on top of the air inlet housing.

Oil is supplied from the aircraft tank to the inlet of the pressure pump, after pressurisation flows through the filter, the system pressure is regulated to 50 to 70 psi by the pressure regulating valve. A by pass valve provide oil supply in the event of blockage of filter and a check valve prevents oil flow when engine is stoped.

The secavange pump which is incorporated in the main oil pump and the three independent secavange pumps are so located that they will secavange oil from the power section in any normal attitude of aircraft flight.

The secavange pump located in the main oil pump, secavange oil from the accessory gear box, the other three secavanges oil from diffuser and front and rear side of turbine. The out put of diffuser and front turbine secavange pump join that of the main secavange pump.

The out put of the rear turbine secavange pump is delivered to the interior of the turbine to compressor tie bolts and compressor rotor tie bolt. This oil is directed to the splines of turbine coupling shaft assembly and to the splines for extension shaft of compressor. Thus the out put of rear turbine secavange pump must be resecavanged by the other three secavange pumps.

A secavange relief valve is located, so that it will prevent excessive pressure build up in the power section secavange system. The combined flows of secavanged oil from the power section and reduction gear secavange system must be cooled and returned to supply tank.

A magnetic plug is located on the bottom of accessory gear box and another on scavange line on the forward side of gear box.

### Reduction Gear Lubricating System

The reduction gear lubricating system includes the following:

#### Pressure Pump

Located on left rear side of reduction gear.

#### Filter

Located in pump body assembly alongwith by - pass valve and check valve.

#### Two Scavange Pumps

One located in the bottom of the rear case, the other in the front case below the propeller shaft.

#### Two Pressure Relief Valves

One for the pressure system and other for scavange system.

Oil flows from the pressure pump through a filter and to all parts with in the reduction gear that requires lubrication. In addition the oil pressure is also used as hydraulic pressure in propeller brake assembly. By pass valve ensures continuous oil supply in the event of filter get contaminated and check valve stops oil flow to reduction gear when engine is stoped. Relief valve limits pressure to 250 psi.

The out put of scavange pumps returns the oil to oil tank by common outlet to the aircraft system. A relief valve limits the scavange pressure, as system pressure, and limits to 250 psi.

A magnetic plug located on the bottom rear of the reduction gear assembly provides a means of draining it.

### LUBRICATION OILS

Gas turbine engines use a low viscosity (thin) synthetic lubricating oil that does not originate from crude oil. The choice of a lubricating oil is initially decided by the loads and operating temperatures of the bearings and the effect that the temperature will have on the viscosity of the oil. Special laboratory and engine tests are then done to prove the suitability of a particular oil for a specific engine and assess the extent to which it deteriorates and the corrosive effects it may have on the engine.

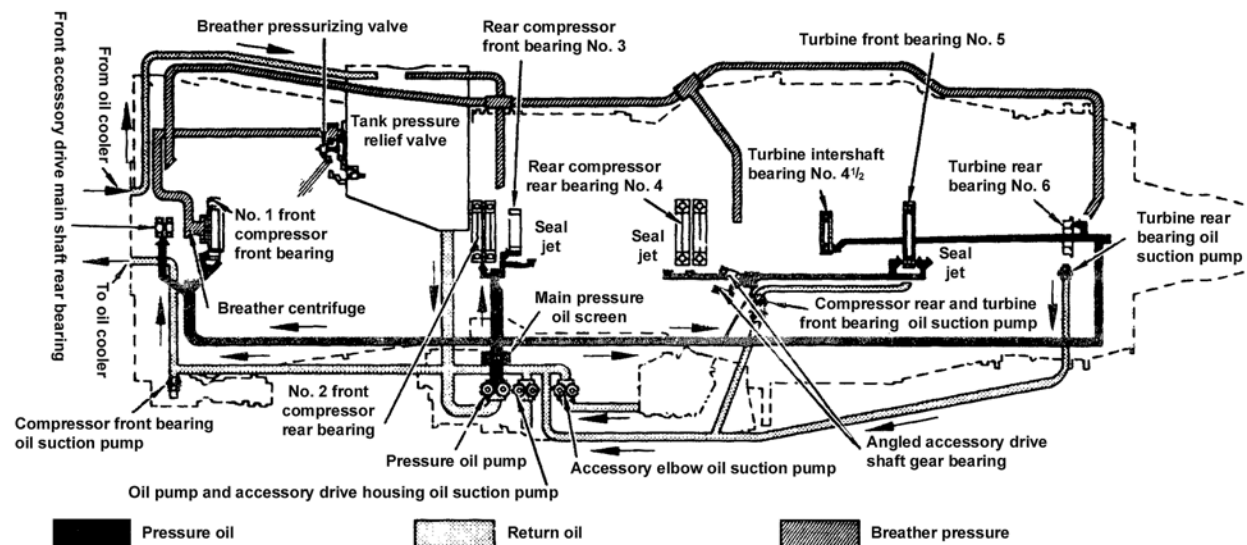

Fig. 3.2. Turbo Jet Lubrication.

The viscosity of a fluid is its resistance to flow and is measured in stokes, a hundredth part of which is a centistoke. This measurement gives a relationship between the specific gravity of the fluid and the force required to move a plane surface of one square centimetre area over another plane surface at the rate of one centimetre per second, when the two surface are separated by a layer of the test fluid one centimetre thick.

The turbojet engine is able to use a low viscosity oil due to the absence of reciprocating parts and heavy duty gearing. This reduces the power requirement for testing, particularly at low temperatures.

Turbo-propeller engines, however, require a slightly higher viscosity oil due to the reduction gear and propeller pitch change mechanism.

All gas turbine oils must retain their lubricating properties and be resistant to oxidation at high temperatures. There are many types of synthetic gas turbine oil and these are manufactured to rigid specifications, but only those specified by the engine manufacturer must be used .

# CHAPTER - 4

## VENTILATION AND COOLING SYSTEM

### PISTON ENGINE

Aircraft engines may be cooled either by air or by liquid, Excessive heat is undesirable in any internal-combustion engine for three principal reasons: (1) It adversely affects the behaviour of the combustion of the fuel-air charge, (2) it weakens and shortens the life of the engine parts, (3) it impairs lubrication.

If the temperature inside the engine cylinder is too great, the fuel mixture will be preheated and combustion will occur before the proper time. Premature combustion causes detonation "knocking," and other undesirable conditions. It will also aggravate the overheated condition and is likely to result in failure of pistons and valves.

The strength of many of the engine parts depends on their heat treatment. Excessive heat weakens such parts and shortens their life. Also, the parts may become elongated, warped, or expanded to the extent that they seize or lock together and stop the operation of the engine.

Excessive heat "cracks" the lubricating oil, lowers its viscosity, and destroys its lubricating properties.

### COOLING

Approximately one third of the energy produced by burning fuel in the engine cylinders manifests itself as heat which is not converted to power. If this heat were not dissipated failure of some of the engine components in direct contact with the combustion process would take place, and the engine would fail. Some of the heat is rejected with the exhaust gases but the remainder must be dissipated so as to maintain the working parts of the engine at a temperature which will ensure that the materials are not adversely affected. However a minimum temperature must be maintained to assist proper lubrication and to provide good fuel evaporation. There are two main methods of cooling, by liquid or by air, but some internal parts are also cooled by heat transfer through the medium of the lubricating oil.

#### Liquid cooling

In liquid cooled engines the cylinders are surrounded by a water jacket, through which liquid (normally a mixture of ethylene glycol and water) is passed to absorb and remove excess heat. The jackets are parts of a closed system, which also includes an engine driven pump and a radiator which projects into the airstream. Some systems are provided with thermostatically controlled radiator shutter, by means of which a suitable coolant temperature is maintained during flight. Liquid cooling has been used mainly on military aircraft engines, but a few examples may still be found on civil aircraft.

#### Air cooling

With air cooled engines, all those parts of the engine which need to be cooled (mainly the cylinders) are provided with fins, the purpose of which is to present a larger cooling surface to the air flowing round them. The size of the fins is related directly to the quantity of heat to be dissipated, thus the fins on the cylinder head give a greater area than those on the cylinder barrel. Baffles and deflectors are fitted round the cylinders to ensure that all surfaces are adequately cooled and the whole engine is cowled to direct airflow past the cylinder to reduce drag. The exit path from the cowling is generally provided with gills or flaps, by means of which the mass air flow may be adjusted to control cylinder temperature. Because air cooling is simple and little maintenance is required, air cooled engines are used in the majority of piston engine aircraft.

### AIR-COOLING OF TURBINE ENGINES

#### Introduction

An important feature in the design of a gas turbine engine is the need to ensure that certain parts of the engine, and in some instances certain accessories, do not absorb heat from the gas stream to an extent that is detrimental to their safe operation. This is achieved by allowing a controlled amount of air from the compressors to flow around these components. The internal cooling airflow is also used to cool the oil, and to pressurize the main bearing housing and various drive shaft seals to maintain the efficiency of the lubrication system by preventing oil leakage. External cooling of the engine power plant is also essential to prevent the transfer of heat to the aircraft structure.

#### Internal cooling

The heat transferred by the turbine blades from the main gas stream to the turbine discs, the bearings of the rotating assemblies, and the engine main casings, is absorbed and dispersed by directing a flow of comparatively cool air over these components. High and low pressure airflows are provided by taking air from both compressors; on completion of its function, the air is either vented overboard or joins the exhaust gas flow.

On the type of engine shown in figure, low pressure (L.P.) air is directed forward to cool the L.P. compressor shaft, and rearward to cool the high pressure (H.P.) compressor shaft. L.P. air is also taken from the by-pass duct and fed to

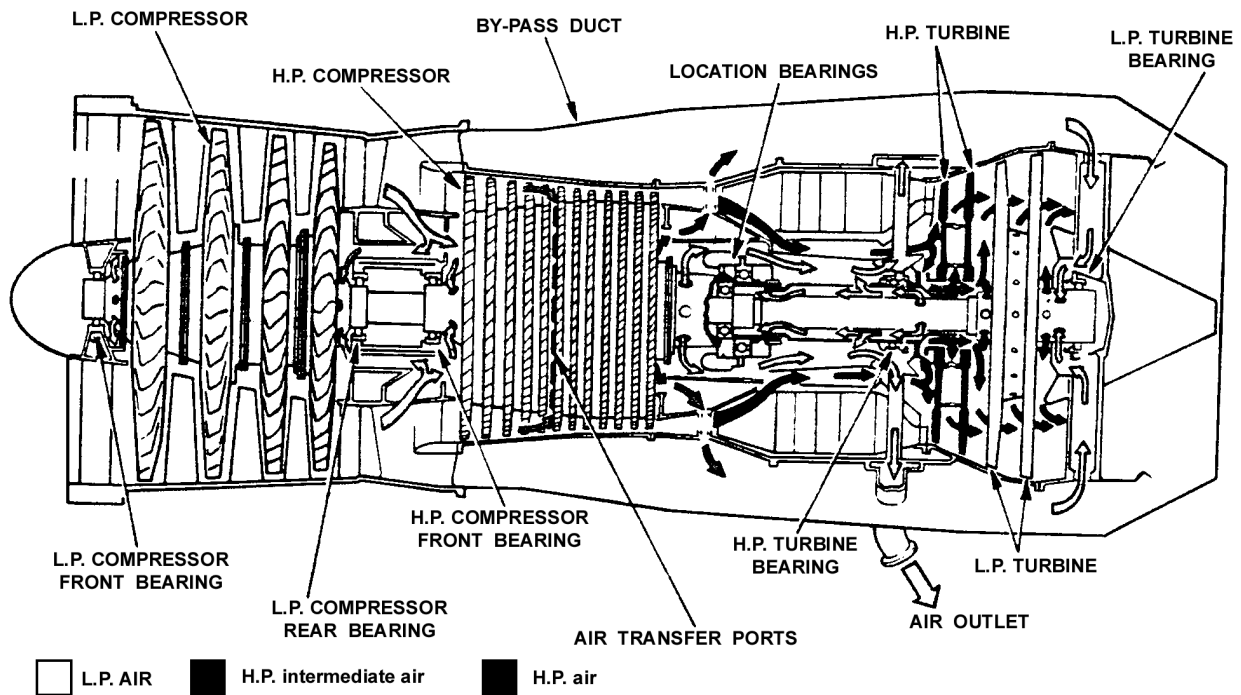

Fig. 4.1. General internal airflow pattern.

the rear of the engine to cool the turbine shafts; the separate L.P. airflows then mix and are ducted overboard after cooling the outer surface of the H.P. turbine shaft. An intermediate H.P. compressor flow is used to cool the rear half of the H.P. compressor shaft and the rear face of the final compressor disc before passing through tubes into the bypass duct.

The H.P. compressor outlet air is directed rearwards onto the turbine discs and, because the flow moves outwards across the discs into the exhaust gas flow, the hot exhaust gases, being of a lower pressure, are prevented from flowing inwards. The outward flow of cooling air is controlled by inter stage air seals of multi-groove construction that provide the faces of the turbine discs with an adequate cooling airflow. The inter stage air seals are formed in two sections; the front section forms the least restriction, the pressure difference across it being less than that across the rear section. This prevents any inward flow of exhaust gases across the seals.

Due to the high temperature of the gas stream at the turbine inlet, it is often necessary to provide internal air cooling of the nozzle guide vanes and, some instances, the turbine blades. Turbine blade life will depend not only on the form of the cooled blade, but also the method of cooling; therefore, the flow design of the blade internal passages is important. Recent development of turbine blade cooling is to provide an efficient axial flow of cooling air directly into the blade instead of a pressure feed through the inter stage; this is known as pre-swirl feed.

A variation in temperature of the cooling air will give some indication of engine distress, either by a thermal switch operating a warning indicator at a predetermined temperature or through a thermocouple system to a temperature gauge.

### Accessory cooling

A considerable amount of heat is produced by some of the engine accessories, of which electrical generator is an example, and these may often require their own cooling circuit. Air is sometimes ducted from intake louvres in the engine cowlings or it may be taken from a stage of the compressor.

When an accessory is cooled during flight by atmospheric air passing through louvres, it is usually necessary to provide an induced circuit for use during static ground running, when there would be no external air flow. This is achieved by allowing compressor delivery air to pass through nozzles situated in the cooling air outlet duct of the accessory. The air velocity through the nozzles creates a low pressure area which forms an ejector, so inducing a flow of atmospheric air through the intake louvres. To ensure that the ejector system operates only during ground running, the flow of air from the compressor is controlled by a pressure control valve. This valve is electrically opened by a switch that is operated when the weight of the aircraft is supported by the undercarriage.

### External cooling and ventilation

The engine bay or pod is usually cooled by atmospheric air being passed around the engine and then vented over board. Conventional cooling during ground running may be provided by using an internal cooling outlet vent as an ejector

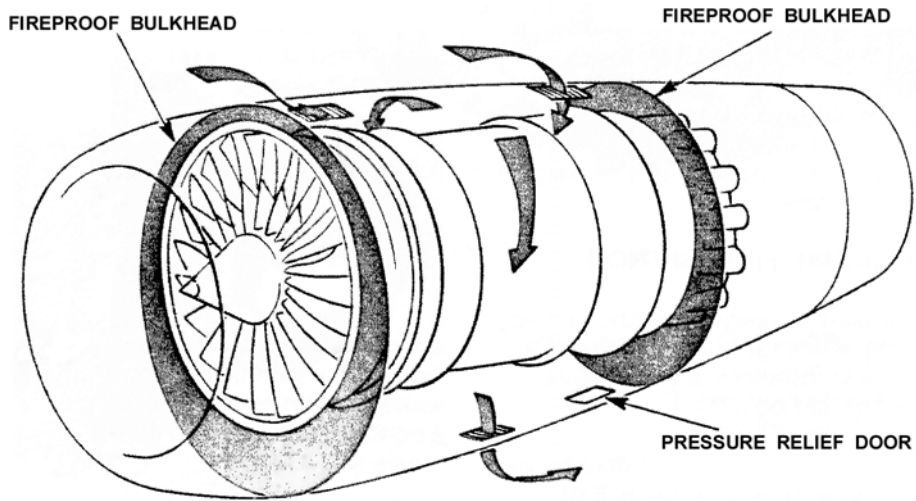

Fig. 4.2. A typical cooling and ventilation system.

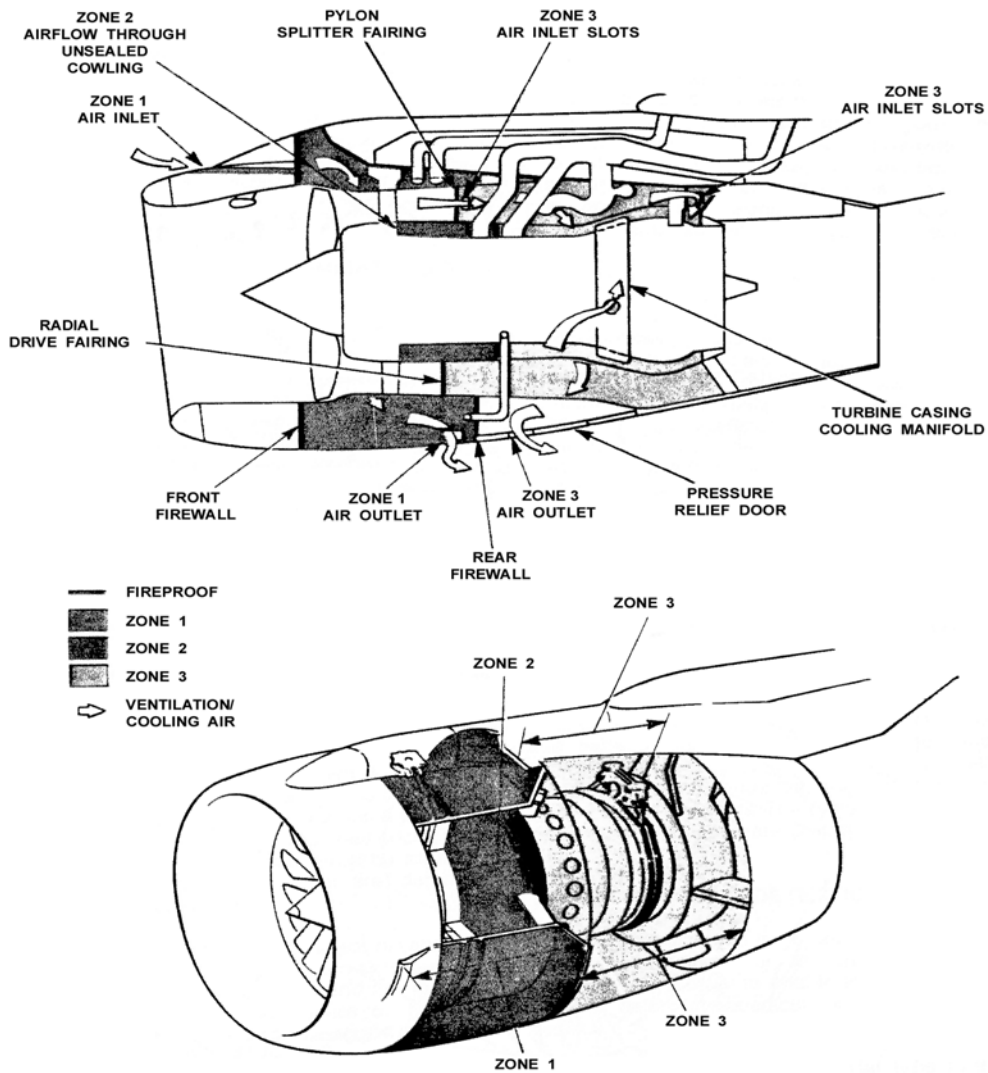

Fig. 4.3. Cooling and ventilation-fan engine.

system. An important function of the cooling air flow is to purge any inflammable vapours from the engine compartment.

By keeping the airflow minimal, the power plant drag is minimized and, as the required quantity of fire extinguishant is in proportion to the zonal airflow . Any fire outbreak would be of low intensity.

A fireproof bulkhead is also provided to separate the 'cool' area or zone of the engine, which contains the fuel, oil, hydraulic and electrical systems, from the 'hot' area surrounding, the combustion, turbine and exhaust sections of the engine. Differential pressures can be created in the two zones by calibration of the inlet and outlet apertures to prevent the spread of fire from the hot zone.





# CHAPTER - 5

## THE THRUST REVERSER

### INTRODUCTION

Jet engines installed in jet airlines are equipped with thrust reversers to provide a braking action after the airplane has landed. The thrust reverser blocks gas flow to the rear and directs it forward to produce reverse thrust up to 5,000 lb. or more. The reverse thrust is produced when the air baffle doors or "clamshells" are moved into the gas stream by actuating cylinders controlled by the reverse thrust lever in the cockpit. Fig. 5.1 below is a drawing of a typical thrust reverser unit designed for use with the General Electric CJ805 jet engine.

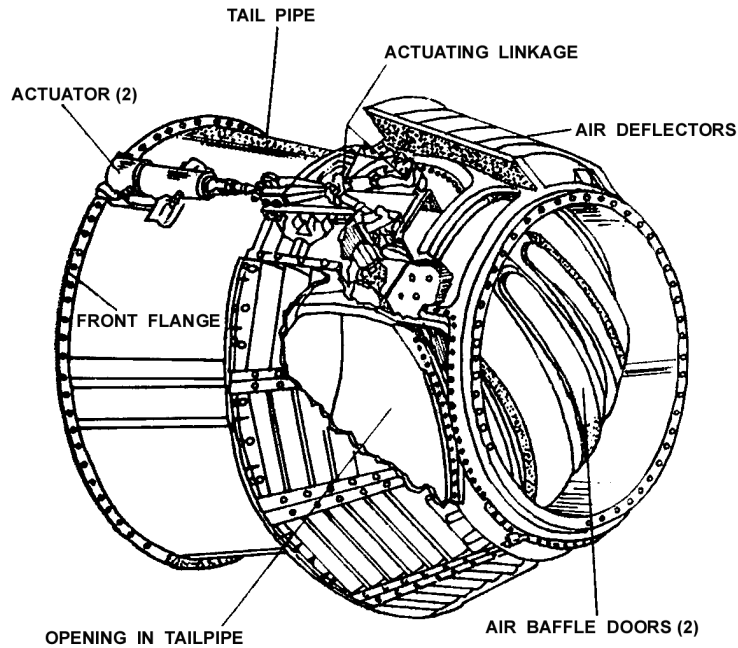

Fig. 5.1. Thrust reverser unit.

### PRINCIPLES OF OPERATION

There are several methods of obtaining reverse thrust on turbo-jet engines; three of these are shown in fig. 5.2 and explained in the following paragraphs.

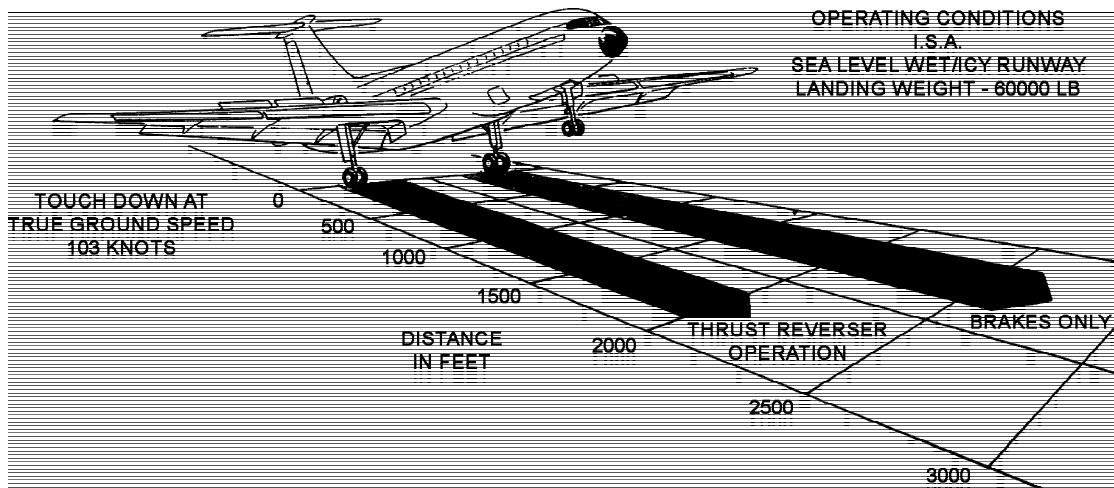

Fig. 5.2. Comparative landing runs with and without thrust reversal.

One method uses clamshell-type deflector doors to reverse the exhaust gas stream and second uses a target system with external type to do the same thing. The third method used on fan engines utilizes blocker doors to reverse the cold stream airflow.

Methods of reverse thrust selection and the safety features incorporated in each system described are basically the same. A reverse thrust lever in the crew compartment is used to select reverse thrust; the lever cannot be moved to the reverse thrust position unless the engine is running at a low power setting, and the engine cannot be opened up to a high power setting if the reverser fails to move into the full reverse thrust position. Should the operating pressure fall or fail, a mechanical lock holds the reverser in the forward thrust position; this lock cannot be removed until the pressure is restored. Operation of the thrust reverser system is indicated in the crew compartment by a series of lights.

**Clamshell Door System**

The clamshell door system is a pneumatically operated system, as shown in detail in fig. 5.3. Normal engine operation is not affected by the system, because the ducts through which the exhaust gases are deflected remain closed by the doors until reverse thrust is selected by the pilot.

On the selection of reverse thrust, the doors rotate to uncover the ducts and close the normal gas stream exit. Cascade vanes then direct the gas stream in a forward direction so that the jet thrust opposes the aircraft motion.

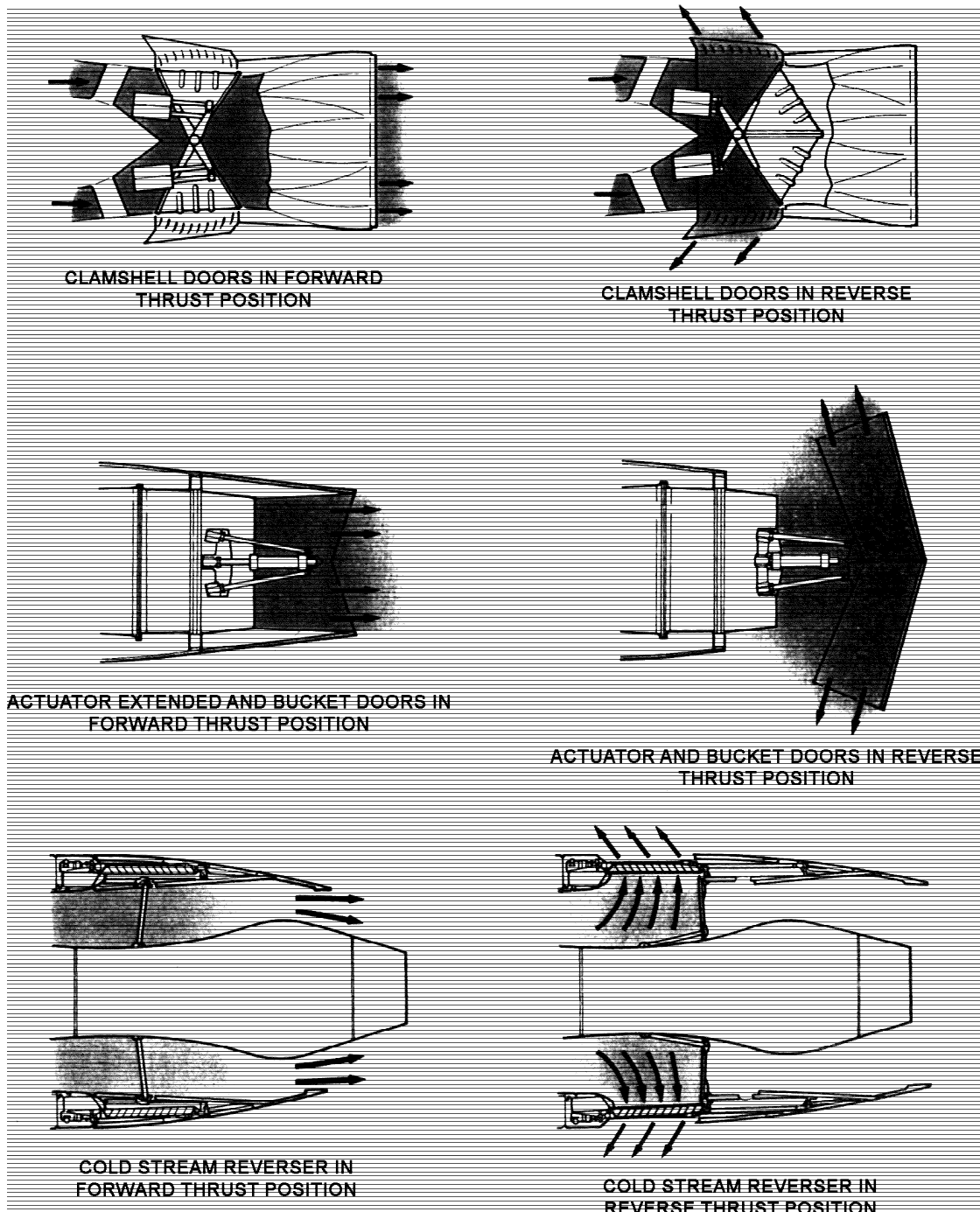

Fig. 5.3. Methods of thrust reversal.

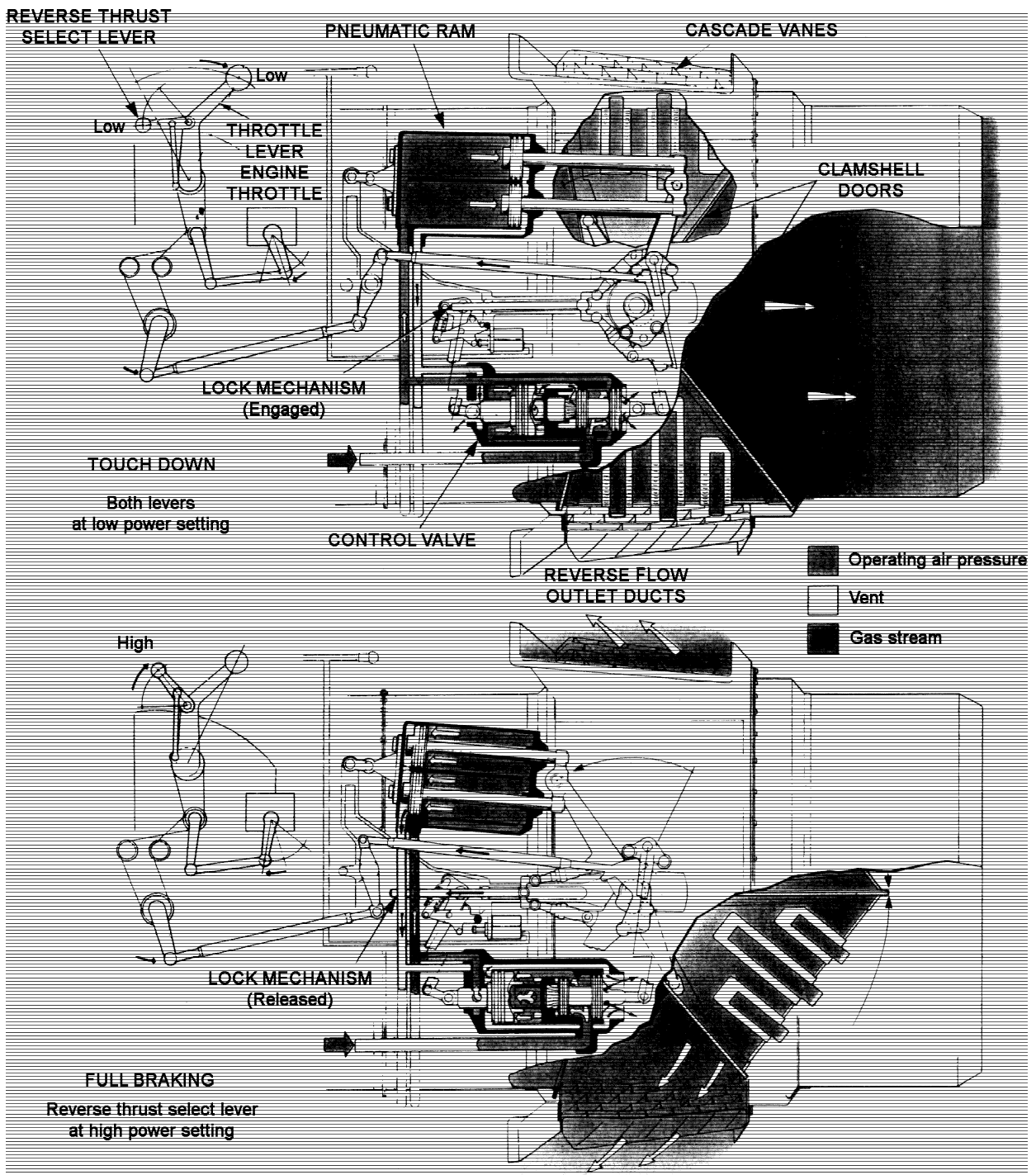

Fig. 5.4. A typical thrust reverser system using clamshell doors.

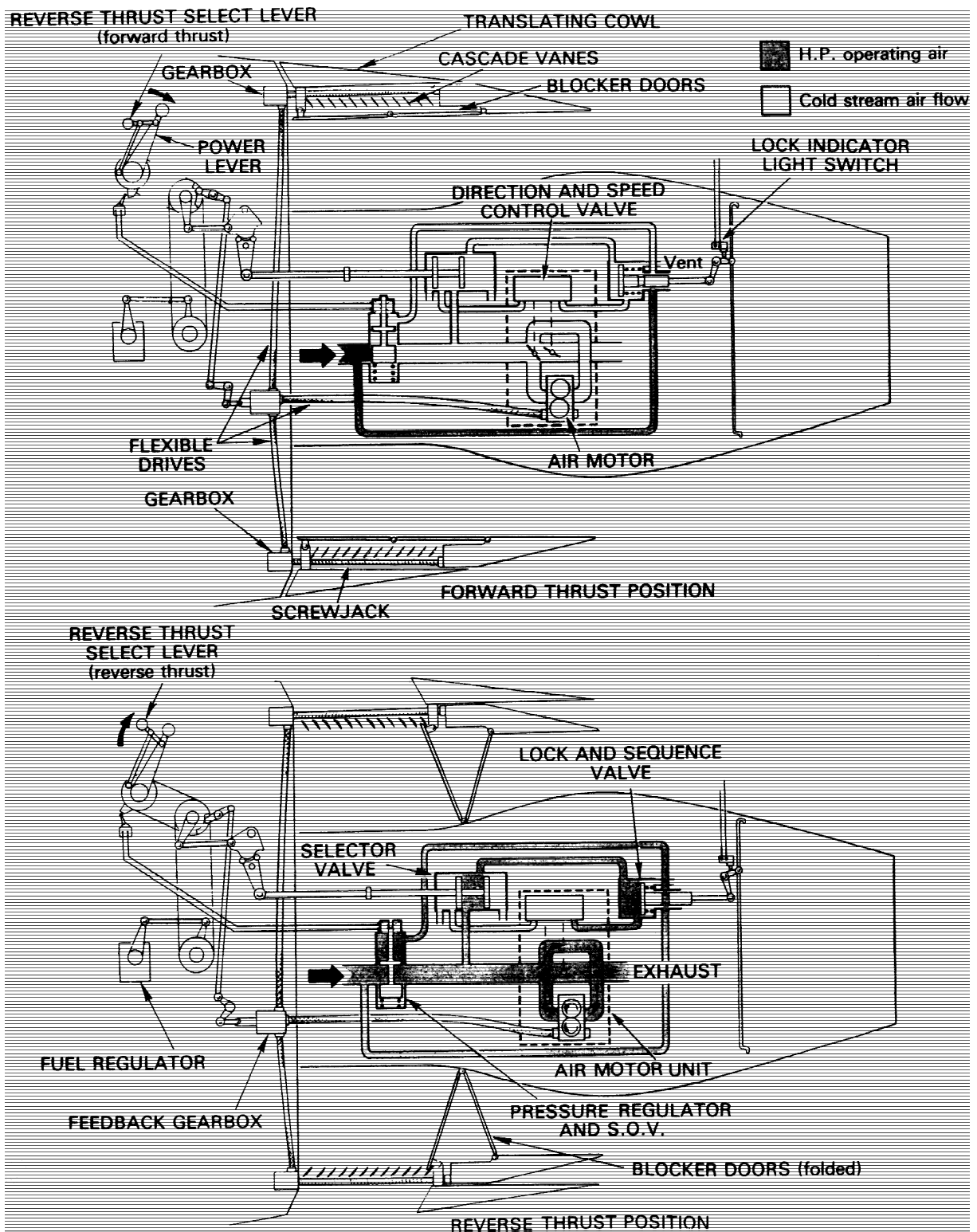

Fig. 5.5. A typical fan cowl stream thrust reversal system.

The clamshell doors are operated by pneumatic rams through levers that give the maximum load to the doors in the forward thrust position; this ensures effective sealing at the door edges, so preventing gas leakage. The door bearings and operating linkage operate without lubricant at temperatures of up to 600 deg. C.

### Bucket Target System

The bucket target system is hydraulically actuated and uses bucket-type doors to reverse doors are actuated by means of a conventional pushrod system. A single hydraulic powered actuator is connected to a drive idler, actuating the doors through a pair of pushrods (one for each door).

The reverser doors are kept in synchronization through the drive idler. The hydraulic actuator incorporates a mechanical lock in the stowed (actuator extended) position.

In the forward thrust mode (stowed) the thrust reverser doors form the convergent-divergent final nozzle for the engine.

### Cold Stream Reverser System

The cold stream reverser system (fig. 5.4) can be actuated by an air motor, the output of which is converted to mechanical movement by a series of flexible drives, gearboxes and screwjacks, or by a system incorporating hydraulic rams.

When the engine is operating in forward thrust, the cold stream final nozzle is 'open' because the cascade vanes are internally covered by the blocker doors (flaps) and externally by the movable (translating) cowl; the latter item also serves to reduce drag.

On selection of reverse thrust, the actuation system moves the translating cowl rearwards and at the same time folds the blocker doors to blank off the cold stream final nozzle, thus diverting the airflow through the cascade vanes.

### Turbo-Propeller Reverse Pitch System

Reverse thrust action is affected on turbo-propeller powered aircraft by changing the pitch of the propeller blades through a hydro-mechanical pitch control system (fig 5.5). Movement of the throttle or power control lever directs oil

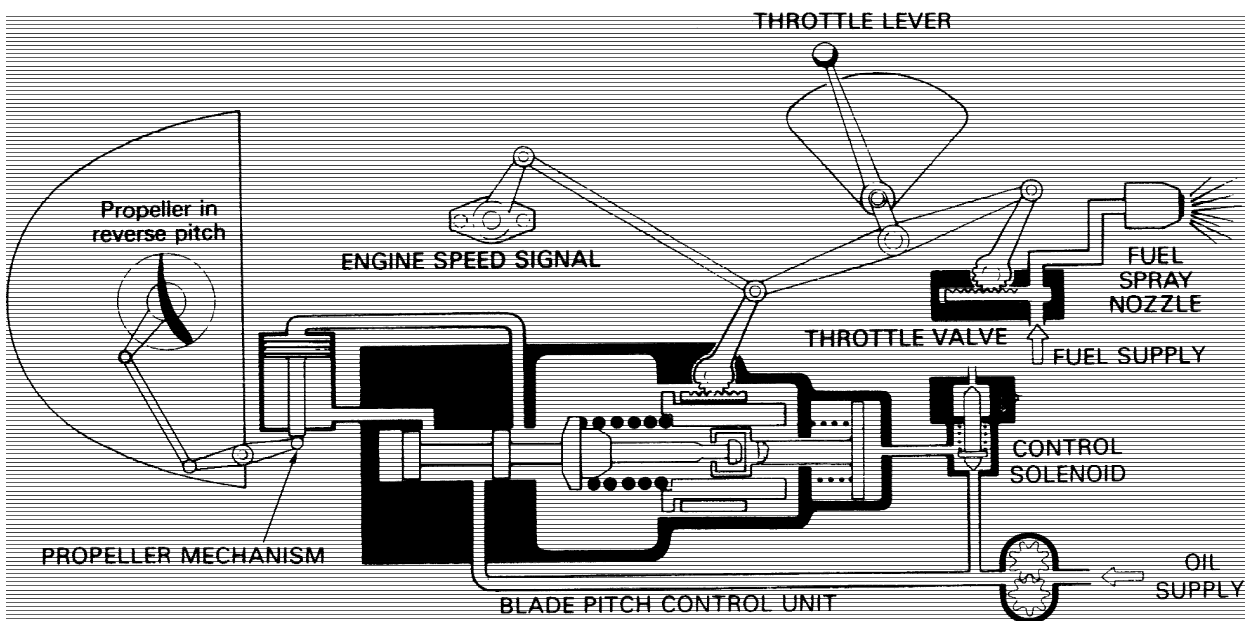

Fig. 5.6. A propeller pitch control system.

from the control system to the propeller mechanism to reduce the blade angle to zero, and then through to negative (reverse) pitch. During throttle lever movement, the fuel to the engine is trimmed by the throttle valve, which is interconnected to the pitch control unit, so that engine power and blade angle are co-ordinated to obtain the desired amount of reverse thrust. Reverse thrust action may also be used to manoeuvre a turbo-propeller aircraft backwards after it has been brought to rest.

Several safety factors are incorporated in the propeller control system for use in the event of propeller malfunction, and these devices are usually hydro-mechanical pitch locking devices or stops.



# CHAPTER - 6

## FUEL SYSTEM TURBINE ENGINES

### INTRODUCTION

The functions of the fuel system are to provide the engine with fuel in a form suitable for combustion and to control the flow to the required quantity necessary for easy starting acceleration and stable running, at all engine operating conditions, to do this, one or more fuel pumps are used to deliver the fuel to the fuel spray nozzles, which inject it into the combustion system in the form of an atomized spray because the flow rate must vary according to the amount of air passing through the engine to maintain a constant selected engine speed or pressure ratio, the controlling devices are fully automatic with the exception of engine power selection, which is achieved by a manual throttle or power lever. A fuel shut-off valve (cock) control lever is also used to stop engine, although in some instances these two manual controls are combined for single-lever operation.

It is also necessary to have automatic safety controls that prevent the engine gas temperature, compressor delivery pressure, and the rotating assembly speed, from exceeding their maximum limitations.

With the turbo-propeller engine, changes in propeller speed and pitch have to be taken into account due to their effect on the power output of the engine. Thus, it is usual to interconnect the throttle lever and propeller controller unit, for by so doing the correct relationship between fuel flow and airflow is maintained at all engine speeds and the pilot is given single-lever control of the engine. Although the maximum speed of the engine is normally determined by the propeller speed controller, over speeding is ultimately prevented by a governor in the fuel system.

Fuel system also provides oil cooling for lubricating system of various engine parts.

There are two types of fuel control i.e. Automatic and Manual. Automatic control system is divided into 3 parts they are : (i) Pressure Control System (ii) Flow control system (iii) Acceleration and speed control.

Some engines are fitted with an electronic system of control and this generally involves the use of electronic circuits to measure and translate changing engine condition to automatically adjust the fuel pump output. On helicopters powered by gas turbine engines using the free power turbine principle, additional manual and automatic controls on the engine govern the free power turbine and consequently aircraft rotor speed.

### FUEL CONTROL SYSTEMS

Typical high pressure (H.P.) fuel control systems for a turbo-propeller engine and a turbojet engine are shown in simplified form in figure 1, each basically consisting of an H.P. pump, a throttle control and a number of fuel spray nozzles. In addition, certain sensing devices are incorporated to provide automatic control of the fuel flow in response to engine requirements. On the turbo-propeller engine, the fuel and propeller systems are coordinated to produce the appropriate fuel/r.p.m. combination.

The usual method of varying the fuel flow to the spray nozzles is by adjusting the output of the H.P. fuel pump. This is effected through a servo system in response to some or all of the following :

1. Throttle Movement.
2. Air, temperature and pressure.
3. Rapid acceleration and deceleration.
4. Signals of engine speed, engine gas temperature and compressor delivery pressure.

### FUEL PUMP

On some early turbine engines a constant displacement pump was used, the design of which ensured that pump delivery was always in excess of engine requirements. Excess fuel was bled back to the fuel tanks by means of unit called a Barostat which was sensitive to changes in air intake pressure. Most modern British systems employ a pump of the variable stroke (swash-plate) type, a dual pump often being fitted on large engines to obtain high delivery rates.

The variable stroke pump is driven directly from the engine and consists of rotating cylinder block in which a number of cylinders are arranged around the rotational axis. A spring-loaded piston in each cylinder is held against a non-rotating cam plate so that rotation of the cylinder block results in the pistons moving up and down in their respective cylinders. Conveniently placed ports in the pump body allow fuel to be drawn into the cylinders and discharged to the engine. The angle of the cam plate determines the length of stroke of the piston and, by connecting it to a servo mechanism, delivery may be varied from the nil to maximum pump capacity for a given pump speed.

The servo piston operates in a cylinder and is subjected to pump delivery pressure on one side and the combined forces of reduced delivery (servo) pressure and a spring on the other. A calibrated restrictor supplies pump delivery fuel to the spring side of the piston and this is bled off by the control system to adjust the piston position and hence the angle of the cam plate.

### FUEL PUMP CONTROL SYSTEMS

Some engines are fitted with a control system which uses electronic circuits to sense changing fuel requirements and adjust pump stroke. Most engines however, use hydro-mechanical systems, with an electromechanical element to control maximum gas temperature and these are discussed in the following paragraphs.

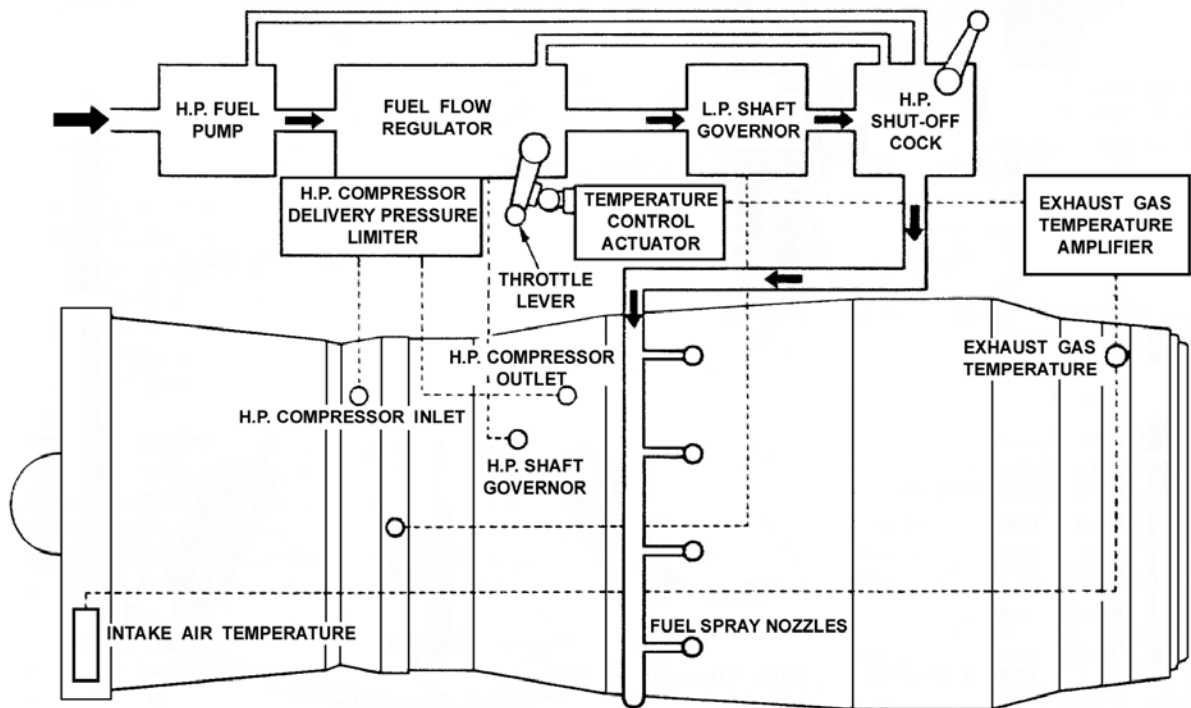
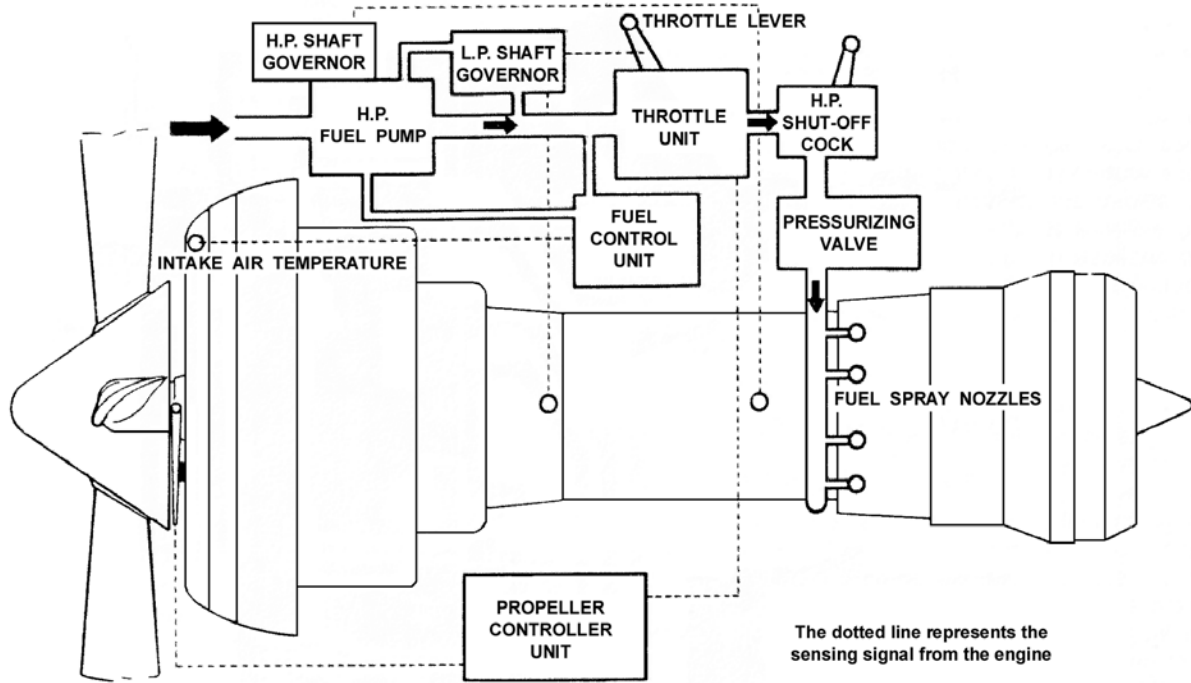

Fig. 6.1. Simplified fuel system for turbo propeller and turbo jet engines.

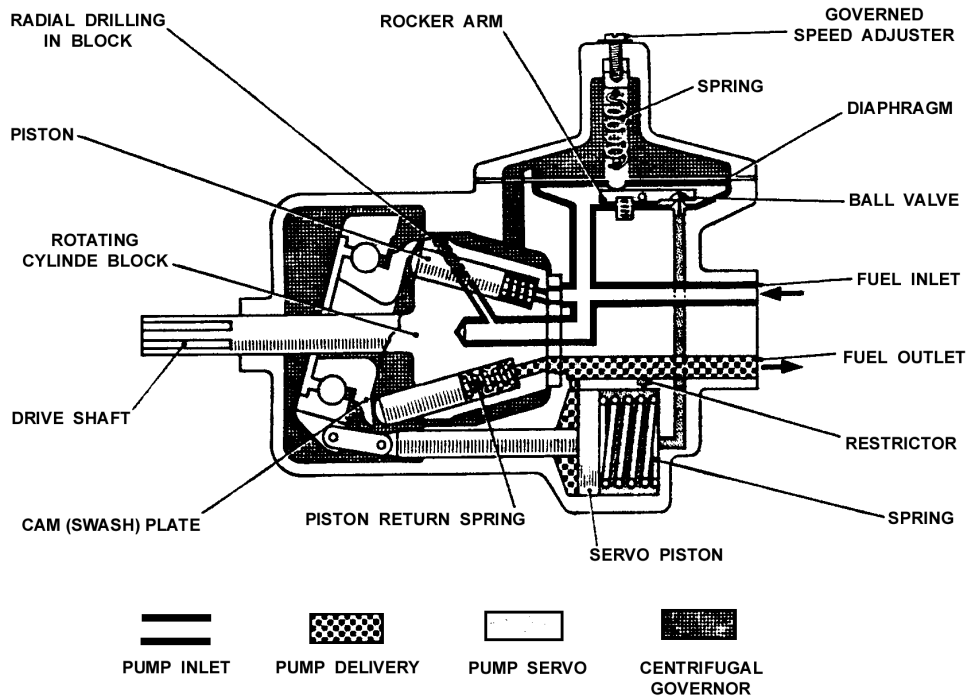

Fig. 6.2. Fuel pump.

**Pressure controller**

The quantity of fuel passing through a restrictor (the throttle valve may be varied by increasing or decreasing the fuel pressure. In the pressure control system (fig. 6.3.) fuel pressure is varied in relation to air intake pressure, decreasing with decreased mass air flow through the engine, Spill valves in the Barometric Pressure Control (B.P.C), Acceleration Control Unit (A.C.U.) and pump governor, bleed off servo pressure to control pump stroke.

Under steady running conditions below maximum governed speed only the B.P.C. spill valve is open. A capsule subject to air intake pressure, contained in the B.P.C., controls the extent to which the spill valve is open. The bleed is arranged to increase as intake pressure decreases thus reducing servo pressure, pump stroke and fuel delivery pressure as altitude increases.

When the throttle is opened slowly, reduced throttle inlet pressure is transmitted to the B.P.C. and the spill valve

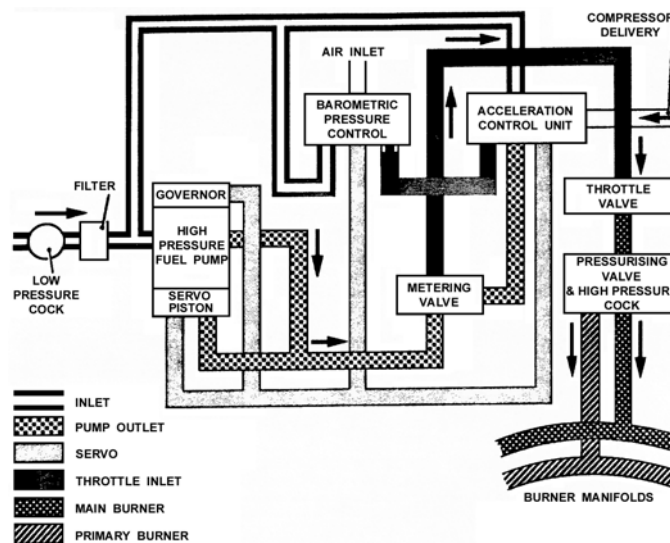

Fig. 6.3. Pressure control system.



closes to increase servo pressure and pump stroke. As pressure to the throttle is restored the B.P.C. spill valve again takes up its controlling position, and pump stroke, combined with increased pump speed, stabilises to give the output for the new throttle position. If the aircraft is in level flight the increasing speed will increase intake pressure and act on the B.P.C. capsule to further increase fuel flow to match the increasing mass air flow.

During rapid throttle opening, the action of the B.P.C. spill valve closes, increased fuel flow creates an increased pressure drop across the Metering Valve which is sensed by the A.C.U. fuel diaphragm. Movement of this diaphragm opens the A.C.U. spill valve to reduce servo pressure and limit over fuelling to the maximum amount which can be tolerated by the engine. As the engine accelerates, increasing compressor delivery pressure acting on the A.C.U. air diaphragm gradually closes the spill valve to permit greater acceleration at higher engine speeds.

Radial drilling in the fuel pump rotor direct fuel under centrifugal force to one side of a spring loaded diaphragm in the governor unit. When centrifugal force reaches a predetermined value the diaphragm flexes sufficiently to open its spill valve and reduce servo pressure, thus limiting the amount of fuel delivered to the engine and so controlling engine speed.

**Flow control**

In this system fuel pump delivery is controlled to maintain a constant pressure drop across the throttle valve regardless of engine speed. A common variation of the system is one in which a small controlling flow (proportional flow) is created with the same characteristics as the main flow and is used to adjust the main flow. A different type of spill valve known as a “kinetic” valve is used which consists of opposing jets of fuel at pump delivery pressure and servo pressure; a blade moving between the jets alters the effect of the high pressure on the low pressure. When the blade is clear of the jets, servo pressure is at maximum and moves the fuel pump to maximum stroke but as the blade comes between the jets servo pressure reduces to shorten pump stroke. The control elements which are housed in a single unit called the Fuel Control Unit (F.C.U.) and throttle, which sometimes also functions as a shut-off (H.P.) cock. the system is illustrated in figure. 6.4.

Under steady running conditions below governed speed, flow through two P.V.U. restrictors is proportional to flow through the throttle valve and the P.V.U. diaphragm is held open by spring pressure, allowing fuel to flow through the A.S.U. back to the pump inlet. The A.S.U. adjusts servo pressure in relation to this proportional flow by means of a kinetic spill valve.

When the throttle is opened slowly the pressure drop across and throttle valve and P.V.U. restrictors decreases and the P.V.U. diaphragm adjusts its position to reduce proportional flow through the A.S.U. This results in the A.S.U. spill valve closing slightly to increase servo pressure and therefore pump stroke, thus restoring the pressure difference across the throttle and P.V.U. restrictors.

Variation in air intake pressure are sensed by a capsule in the A.S.U. which adjusts its spill valve to decrease or increase servo pressure as required. The resulting change in proportional flow returns the A.S.U. spill valve to its controlling position.

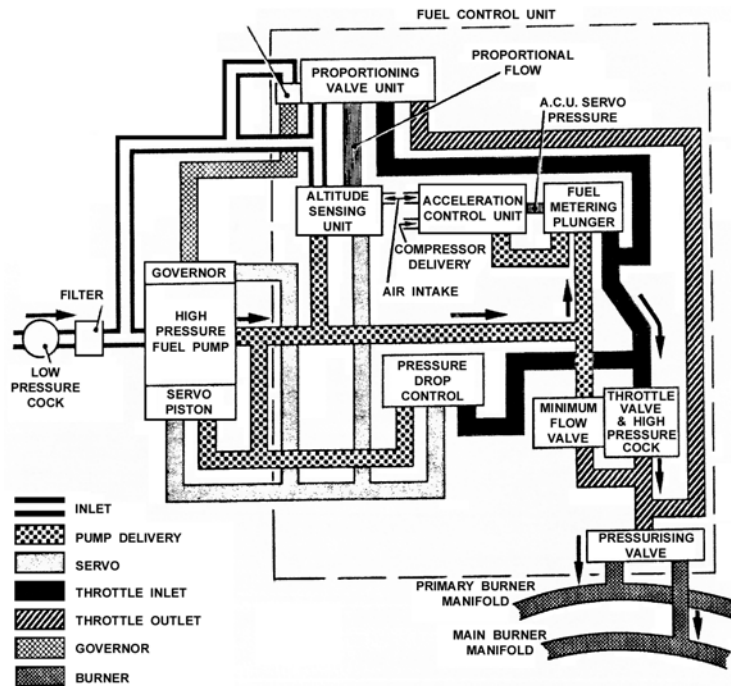

Fig. 6.4. Flow control system.

During rapid throttle opening the sudden decrease in pressure drop across the throttle is sensed by the A.S.U. which closes its spill valve to increase pump stroke. The rapid increase in fuel flow, which would cause over fuelling, is restricted by means of a pressure drop diaphragm and metering plunger. This diaphragm is sensitive to the pressure drop across the metering plunger, the latter being located in the main fuel line to the throttle valve. Rapid throttle opening increases the pressure drop across the plunger and at a fixed rate of over fuelling the pressure drop diaphragm flexes sufficiently to open its spill valve and override the A.S.U., maintaining a fixed pressure drop across the metering plunger. The metering plunger is, in effect, a variable area orifice and by means of a capsule in the A.C.U. sensitive to compressor delivery pressure, its position is controlled, over fuelling and engine speed increase, the pressure drop across the throttle valve is gradually restored until the proportional flow reaches a controlling value once more and the A.S.U. spill valve controls pump stroke.

Fuel under centrifugal force from the fuel pump also acts on a diaphragm in the P.V.U. to adjust the position of one of the restrictions and maintain proportional flow at a value suitable for idling.

**Combined acceleration and speed control**

This fuel pump control system is contained within a single unit called a Fuel Flow Regulator, the fuel pump servo piston being operated by fuel pump delivery pressure opposed by main burner pressure and a spring. The system is illustrated in figure 6.5.

Two rotating assemblies, each with a hollow valve and centrifugal governor, are driven from the engine by a gear train in the regulator and are known as the Speed Control Unit and the Pressure Drop Unit. The speed control valve is given axial movement by a capsule assembly under compressor delivery pressure and has a triangular hole known as the Variable Metering Orifice (V.M.O.). A non rotating governor sleeve round this valve is given axial movement by the governor unit and restricts fuel flow through the V.M.O. Fuel from the pump outlet flows from the regulator body through the V.M.O. to the inside of the speed control valve and passes through the hollow valve to the pressure drop unit. The pressure drop valve is in the form of a hollow piston, moving axially under the force of fuel from the V.M.O. and governor flyweights, has an unrestricted outlet through the regulator body for primary burner fuel and a triangular outlet known as the Pressure Drop Control Orifice (P.D.C.O.) through which fuel flow to the main burners is restricted by the axial movement of the pressure drop valve.

Under steady running conditions the position of the speed control valve is fixed by the capsule assembly and the governor sleeve is held in a fixed axial position, the drop valve which adjusts its position and the exposed area of the P.D.C.O. to supply the correct quantity of fuel in relation to engine speed.

When the throttle is opened slowly, spring loading on the speed control governor increases to move the governor sleeve and increase the V.M.O. area. Pressure drop across the V.M.O. decreases and this is sensed by the pressure drop valve which moves to increase the size of the P.D.C.O. the reduced system pressure difference acting on the pump servo piston

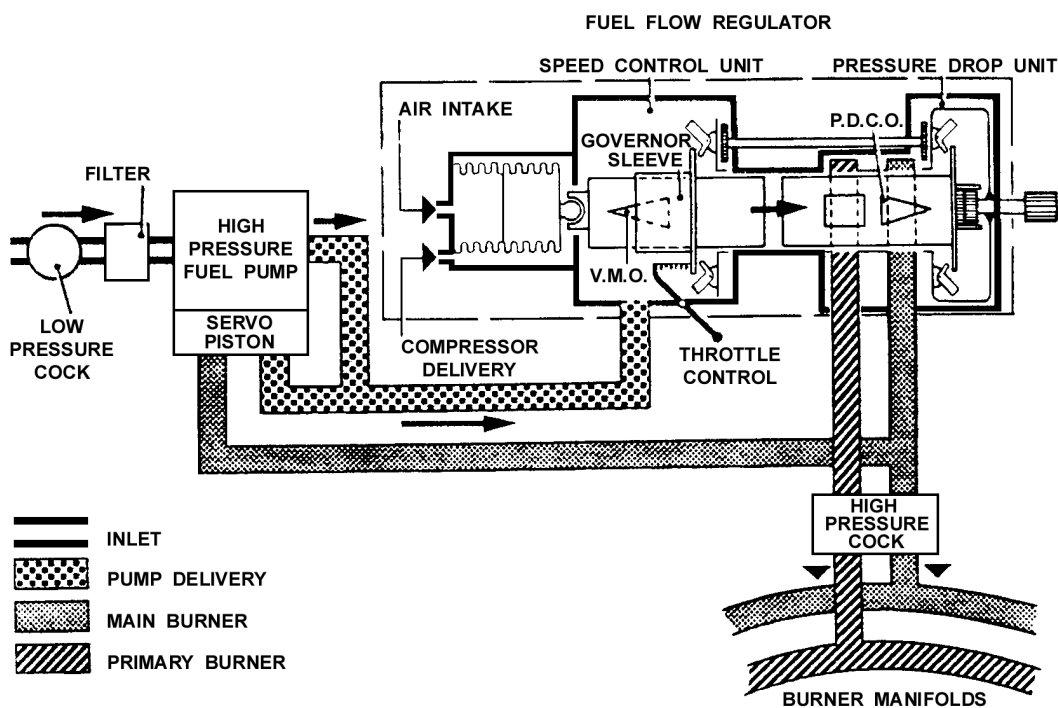

Fig. 6.5. Combined acceleration and speed control.

to increase fuel flow to the engine. As the engine accelerates, the capsule in the speed control unit is compressed due to compressor delivery pressure and moves the speed control valve to further increase the size of the V.M.O. Balance is restored when centrifugal force acting on the speed control governor moves the governor sleeve to restore the system pressure difference.

The effect to rapid throttle movements is restricted by mechanical stops acting on the governor sleeve. Changes in altitude or forward speed affect the capsule of the speed control unit which adjusts the position of the speed control valve to correct fuel flow.

### **BURNERS**

The purpose of the burners is to provide fuel to the engine in a suitable form for combustion. A burner with a single spray nozzle, although used on some early engines, is not suitable for large modern engines due to the widely varying fuel flow requirements for different flight conditions.

If the orifice were of the size suitable for atomising fuel at low rates of flow the pressure required at take-off would be tremendously high, flow through an orifice being proportional to the square of the pressure drop across it.

One of the methods used to overcome this problem is the provision of a dual spray burner. The central orifice provides the fuel for low flow rates and a second annular orifice is used in addition for high flow rates. Distribution between the primary (low flow) manifold and the main (high flow) manifold is normally controlled by a pressure operated valve. In the case of the Fuel flow Regulator, fuel flowing through the rectangular outlet from the pressure drop valve is always at a higher pressure than fuel flowing through the outlet from the P.D.C.O. and is used to supply the primary burner manifold.

Another method used on some engines is known as the Vaporising Burner. Fuel is injected at low pressure into one end of a hollow "U" shaped tube located in the combustion chamber. It mixes with the primary air flow, is vaporised by the heat in the chamber and ejected upstream into the combustion zone. In this system a separate burner is necessary for engine starting.

### **ADDITIONAL CONTROLS**

In addition to, the system usually is provided to prevent the engine from exceeding operating limitations.

#### **Turbine gas temperature control**

Control of the maximum permitted turbine gas temperature is often exercised electrically. Signals from the T.G.T. thermocouples are amplified to either actuate a solenoid operated valve in the fuel system or reset the throttle linkage to reduce fuel flow to the burners. On engines which have different T.G.T. limitations for climb and take-off, a switch on the flight deck pre-sets the T.G.T. signal reference datum.

#### **Compressor control**

In certain circumstances such as high forward speed and low ambient temperature it is possible to produce maximum power/thrust at less than maximum engine speed. Under these conditions the engine could sustain damage due to high compressor delivery pressures and fuel flow is restricted by providing a bleed from the A.C.U. capsule, chamber to atmosphere when compressor delivery pressure exceeds a predetermined value.

To prevent the low pressure compressor from exceeding its design speed a centrifugal governor driven from the low pressure shaft is often included in the fuel system. If design speed is exceeded the low pressure governor restricts the fuel flow in the main burner line and reduces both high and low pressure compressor speeds.



# CHAPTER - 7

## ELECTRONIC ENGINE CONTROL AND FUEL METERING SYSTEM

### ELECTRONIC ENGINE CONTROL

#### Introduction

Some engine utilize a system of electronic control to monitor engine performance and make necessary control inputs to maintain certain engine parameters within predetermined limits. The main areas of control are engine shaft speeds and exhaust gas temperature (E.G.T.) which are continuously monitored during function as a limiter only, that is, should engine shaft speed or E.G.T. approach the limits of safe operation, then an input is made to the fuel flow regulator (F.F.R.) to reduce the fuel flow thus maintaining shaft speed or E.G.T. at a safe level. Supervisory control systems may contain a limiter function but, basically, by using aircraft generated data, the system enables a more appropriate thrust setting to be selected quickly and accurately by the pilot. The control system then makes small control adjustments to maintain engine thrust consistent with that pre-set by the pilot, regardless of changing atmospheric conditions. Full authority digital engine control (F.A.D.E.C.) takes over virtually all of the steady state and transient control intelligence and replaces most of the fuel system. The fuel system is thus reduced to a pump and control valve, an independent shut-off cock and a minimum of additional features necessary to keep the engine safe in the event of extensive electronic failure.

Full authority fuel control (F.A.F.C.) provides full electronic control of the engine fuel system in the same way as F.A.D.E.C., but has none of the transient control intelligence capability used to control the compressor airflow system as the existing engine control system is used for these.

The engine supervisory control (E.S.C.) system performs a supervisory function by trimming the fuel flow scheduled by the fuel flow governor (F.F.G.) to match the actual engine power with a calculated engine power for a given throttle angle. The E.S.C. provides supervisory and limiting functions by means of a single control output signal to a torque motor in the F.F.G. In order to perform its supervisory function the E.S.C. monitors inputs of throttle angle, engine bleed state, engine pressure ratio (E.P.R.) and air data computer information (altitude, Mach number and temperatures). From this data the supervisory channel predicts the value of  $N_1$  required to achieve the command E.P.R. calculated for the throttle angle set by the pilot. Simultaneously a comparison is made between the command E.P.R. and the actual E.P.R. and the difference is compared with a programmed datum.

During acceleration the comparator connects the predicted value of  $N_1$  to the limiter channel until the difference between the command and actual E.P.R. is approximately 0.03 E.P.R. At this point the predicted L.P. shaft speed is disconnected and the E.P.R. difference signal is connected to the limiter channel.

The final output from the supervisory channel, in the form of an error signal, is supplied to a 'lowest wins' circuit along with the error signals from the limiter channel. While the three error signals from the limiter channel. While the three error signals remain positive ( $N_1$  and E.G.T. below datum level and actual E.P.R. below command E.P.R.) no output is signalled to the torque motor. If, however, the output stage of the E.S.C. predicts that E.G.T. will exceed datum or that  $N_1$  will either exceed its datum or the predicted level for the command E.P.R., then a signal is passed to the torque motor to trim the fuel flow.

### ELECTRONIC ENGINE CONTROL

Because of the need to control precisely the many factors involved in the operation of modern high-bypass turbofan engines, airlines and manufacturers have worked together to develop electronic engine control (EEC) systems that prolong engine life, save fuel, improve reliability, reduce flight crew workload, and reduce maintenance costs. The cooperative efforts have resulted in two types of EECs, one being the supervisory engine control system and the other the full-authority engine control system. The supervisory control system was developed and put into service first, and is used with the JT9D-7R4 engines installed in the Boeing 767.

Essentially, the supervisory EEC includes a computer that receives information regarding various engine operating parameters and adjust a standard hydromechanical FCU to obtain the most effective engine operation. The hydromechanical unit responds to the EEC commands and actually performs the functions necessary for engine operation and protection.

The full-authority EEC is a system that receives all the necessary data for engine operation and develops the commands to various actuators to control the engine parameters within the limits required for the most efficient and safe engine operation. This type of system is employed on advanced-technology engines such as the Pratt & Whitney series 2000 and 4000.

#### Supervisory EEC System

The digital supervisory EEC system employed with the JT9D-7R4 turbofan engine includes a hydromechanical FCU such as the Hamilton Standard JFC68 described earlier, a Hamilton Standard EEC-103 unit, a hydromechanical air bleed and vane control, a permanent-magnet alternator to provide electric power for the EEC separate from the aircraft electric system, and an engine inlet pressure and temperature probe to sense  $P_{12}$  and  $T_{12}$ . The hydromechanical units of the system control such basic engine functions as automatic starting, acceleration, deceleration, high-pressure rotor speed ( $N_2$ ) governing, VSV compressor position, modulated and starting air-bleed control, and burner pressure ( $P_b$ ) limiting. The EEC provides precision thrust management,  $N_1$  and EGT limiting, and cockpit display information on engine pressure ratio (EPR). It also provides control of modulated turbine-case cooling and turbine-cooling air valves and transmits information regarding parametric and control system condition for possible recording. Such recorded data are utilized by maintenance technicians in eliminating faults in the system.

The supervisory EEC, by measuring EPR and integrating thrust lever (throttle) angle, altitude data, Mach number, inlet air pressure  $P_{12}$ , inlet air temperature  $T_{12}$ , and total air temperature in the computation, is able to maintain constant thrust from the engine regardless of changes in air pressure, air temperature, and flight environment. Thrust changes occur only when the thrust lever angle is changed, and the thrust remains consistent for any particular position of the thrust lever. Takeoff thrust is produced in the full forward position of the thrust level. Thrust settings for climb and cruise are made by the pilot as the thrust lever is moved to a position that provides the correct EPR for the thrust desired. The EEC is designed so that the engine will quickly and precisely adjust to a new thrust setting without the danger of overshoot in  $N_2$  or temperature. It adjusts the hydromechanical FCU through a torque motor electrohydraulic servo system.

In a supervisory EEC system, any fault in the EEC that adversely affect engine operation cause an immediate reversion to control by the hydromechanical FCU. At the same time, the system sends an annunciator light signal to the cockpit to inform the crew of the change in operating mode. A switch in the cockpit enables the crew to change from EEC control to hydromechanical control if it is deemed advisable.

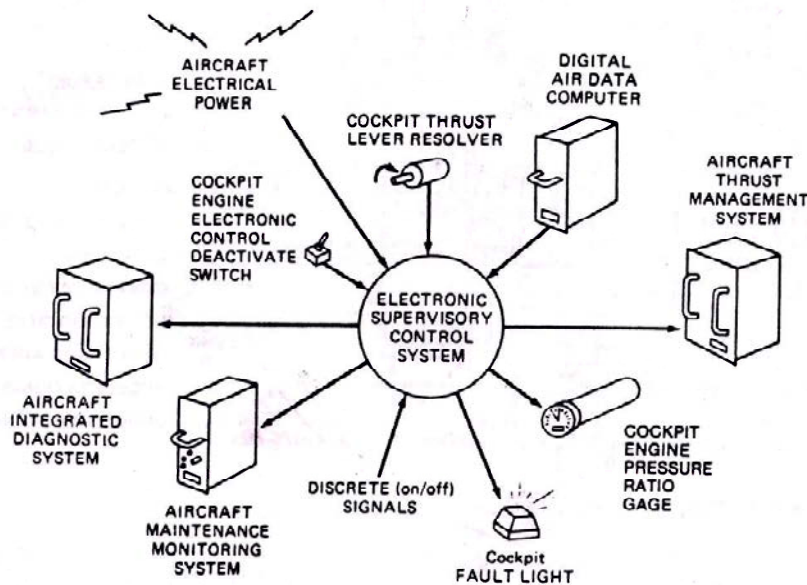

Fig. 7.1. Integration of a supervisory EEC with aircraft systems.

The supervisory EEC is integrated with the aircraft systems as indicated in Fig. 7.1. The input and output signals are shown by the directional arrows. Although the EEC utilizes aircraft electric power for some of its functions, the electric power for the basic operation of the EEC is supplied by the separate engine-driven permanent-magnet alternator mentioned earlier.

The output signals of the supervisory EEC that effect engine operation are the adjustment of the hydromechanical FCU and commands to solenoid-actuated valves for control of modulated turbine-case cooling and turbine-cooling air.

### Full-Authority EEC

A full-authority EEC performs all functions necessary to operate a turbofan engine efficiently and safely in all modes, such as starting, accelerating, decelerating, takeoff, climb, cruise, and idle. It receives data from the aircraft and engine systems, provides data for the aircraft systems, and issues commands to engine control actuators.

The information provided in this section is based on the Hamilton Standard EEC-104, an EEC designed for use with the Pratt & Whitney 2037 engine. The unit is shown in Fig. 7.2. This is a dual-channel unit having a "crosstalk" capability, so that either channel can utilize data from the other channel. This provision greatly increases reliability to the extent that the system will continue to operate effectively even though a number of faults may exist. Channel A is the primary channel, and channel B is the secondary, or backup, channel.

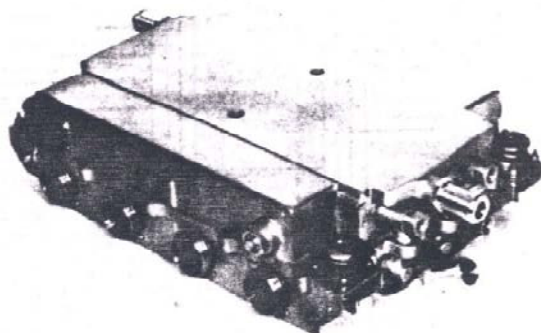

Fig. 7.2. Hamilton Standard EEC-104 electronic engine control.

The following abbreviations and symbols are used in this section to identify functions, systems, and components:

|           |  |
|-----------|--|
| ACC       | Active clearance control                 |
| BCE       | Breather compartment ejector             |
| EEC       | Electronic engine control                |
| EGT       | Exit (exhaust) gas temperature           |
| EPR       | Engine pressure ratio                    |
| FCU       | Fuel control unit                        |
| LVDT      | Linear variable differential transformer |
| $N_1$     | Low-pressure spool rpm                   |
| $N_2$     | High-pressure spool rpm                  |
| $P_{amb}$ | Ambient air pressure                     |
| $P_b$     | Burner pressure                          |
| PMA       | Permanent-magnet alternator              |
| $P_{s3}$  | Static compressor air pressure           |
| $P_{4.9}$ | Exhaust-gas pressure                     |
| TCA       | Turbine-cooling air                      |
| TLA       | Throttle lever angle                     |
| TRA       | Throttle resolver angle                  |
| $T_{12}$  | Engine inlet total air temperature       |
| $T_{4.9}$ | Exhaust-gas temperature                  |
| $w_f$     | Fuel flow                                |

Figure 7.3 is a block diagram showing the relationship among the various components of the EEC system. Input signals from the aircraft to the EEC-104 include throttle resolver angle (which tells the EEC the position of the throttle), service air-bleed status, aircraft altitude, total air pressure, and total air temperature. Information regarding altitude, pressure, and temperature is obtained from the air data computer as well as the  $P_{12}/T_{12}$  probe in the engine inlet.

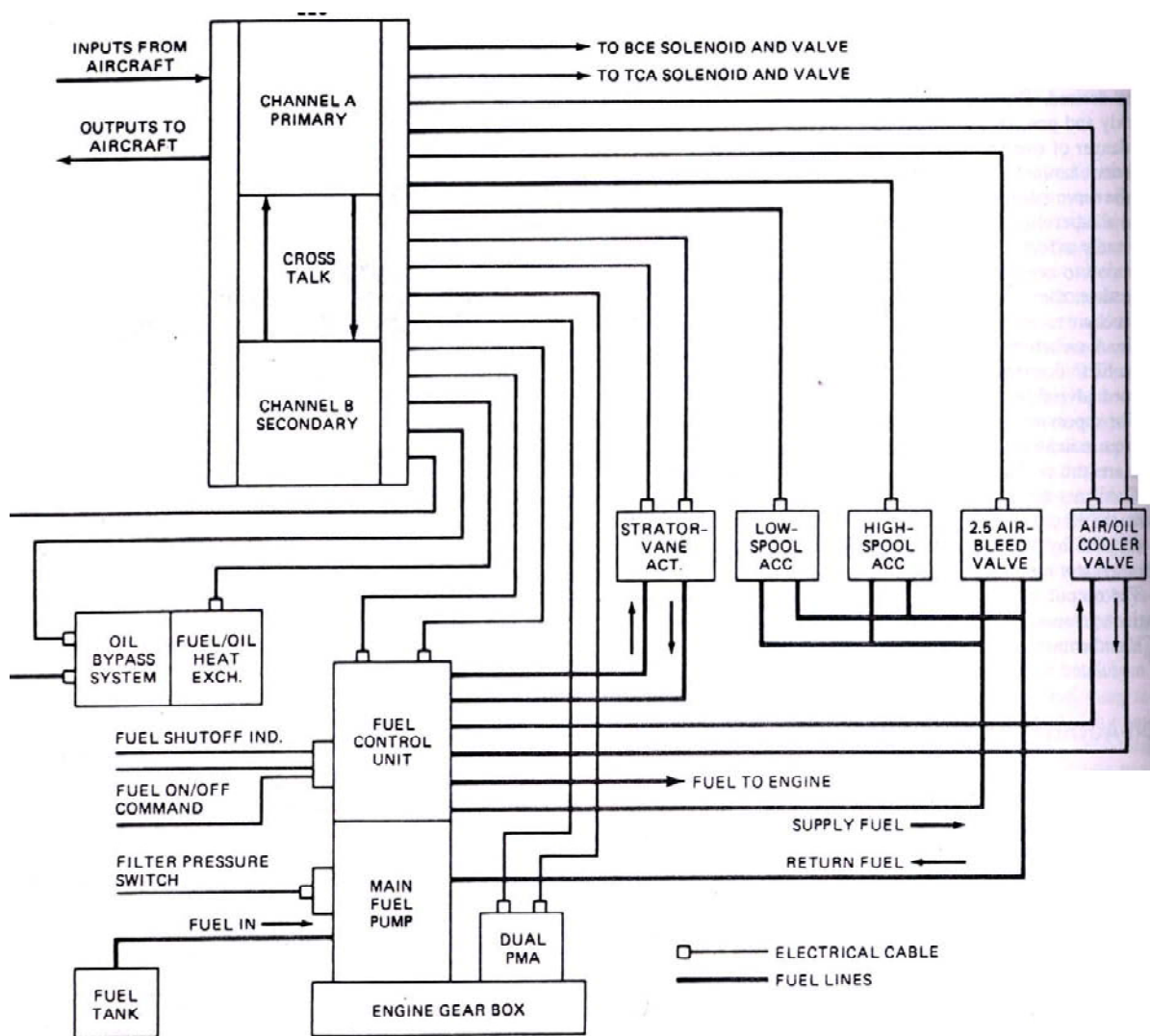

Fig. 7.3. Simplified block diagram of the EEC system with the Hamilton Standard EEC=104

Output from the engine to the EEC include overspeed warning, fuel flow rate, electric power for the EEC, high pressure rotor speed  $N_2$ , stator vane angle feedback, position of the 2.5 air-bleed proximity switch, air/oil cooler feedback, fuel temperature, oil temperature, automatic tailpipe pressure  $P_{4.9}$ , burner pressure  $P_b$ , engine inlet total pressure  $P_{12}$ , low-pressure  $P_{12}$ , low-pressure rotor speed  $N_1$ , engine inlet total temperature  $T_{12}$ , and exhaust-gas temperature (EGT or T4.9). Sensors installed on the engine provide the EEC with measurements of temperatures, pressures and speeds. These data are used to provide automatic thrust rating control, engine limit protection (overspeed, overheat and overpressure), transient control, and engine starting.

Outputs from the EEC to the engine include fuel flow torque motor command, stator vane angle torque motor command, air/oil cooler valve command, 2.5 air-bleed torque motor command, ACC torque motor command, oil bypass solenoid command, ACC torque motor command, oil bypass solenoid command, breather compartment ejector solenoid command, and TCA solenoid command. The actuators that must provide feedback to the EEC are equipped with linear variable differential transformer (LVDTs) to produce the required signals.

During operation of the engine control system, fuel flows from the aircraft fuel tank to the centrifugal stage of the dual-stage fuel pump. The fuel is then directed from the pump through a dual-core oil/fuel heat exchanger which provides deicing for the fuel filter as the fuel is warmed and the oil is cooled. The filter protects the pump main-gear stage and the fuel system from fuel-borne contaminants.

High-pressure fuel from the main-gear stage of the fuel pump is supplied to the FCU, which, through electrohydraulic servo valves, responds to commands from the EEC to position the fuel metering valve, stator vane actuator, and air/oil cooler actuator. Compressor air-bleed and ACC actuators are positioned by electrohydraulic servo valves that are controlled directed by the EEC, using redundant torque motor drivers and feedback elements. The word “redundant” means that units or mechanisms are designed with backup features so that a failure in one part will not disable the unit, and operation will continue normally. Actuator position feedback is provided to the EEC by redundant LVDTs for the actuators and redundant resolvers for the fuel metering valve. Fuel-pump discharge pressure is used to power the stator vane, 2.5 air-bleed, air/oil cooler, and ACC actuators. The EED activates TCA, engine breather ejector, and the aircraft-provided thrust reverser through electrically controlled dual-solenoid valves.

The EEC and its interconnected components are shown in Fig. 7.4. Note that the EEC is mounted on the top left side of the engine fan case. The mounting is accomplished with vibration isolators (shock mountings) to protect the unit.

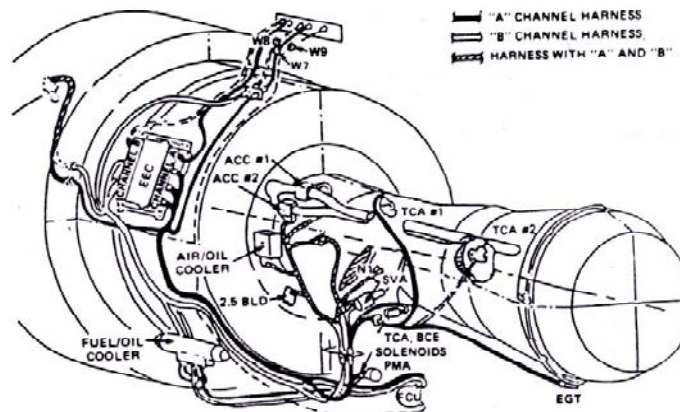

Fig. 7.4. Drawing showing EEC units on an engine.

The benefits of employing a full-authority EEC result in substantial savings for the aircraft operator. Among these benefits are reduced crew workload, reduced fuel consumption, increased reliability, and improved maintainability.

Flight crew workload is decreased because the pilot utilizes the EPR gage to set engine thrust correctly. An EPR gage is shown in Fig. 7.5. To set the thrust, the pilot only has to set the throttle lever angle to a position that results in alignment of the EPR command from the EEC with the reference indicator that is positioned by the thrust management computer. The EEC will automatically accelerate or decelerate the engine to that EPR level without the pilot having to monitor the EPR gage.

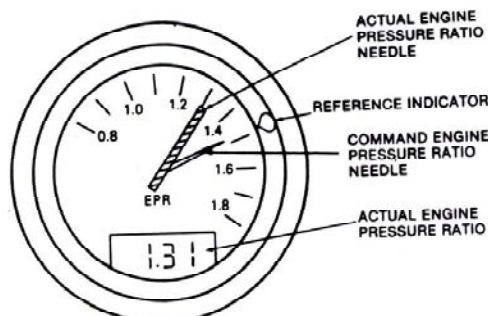

Fig. 7.5. Drawing of an engine pressure ratio gage.

Reduce fuel consumption is attained because the EEC controls the engine operating parameters so that maximum thrust is obtained for the amount of fuel consumed. In addition, the ACC system ensures that compressor and turbine blade clearances are kept to a minimum, thus reducing pressure losses due to leakage at the blade tips. This is accomplished by the ACC system as it directs cooling air through passages in the engine case to control engine case temperature. The EEC controls the cooling airflow by sending commands to the ACC system actuator. Compressor air-bleed and ACC actuator

Engine trimming is eliminated by the use of the full authority EEC. When an engine is operated with a hydromechanical FCU, it is necessary periodically to make adjustments on the FCU to maintain optimum engine performance. To trim the engine, it is necessary to operate the engine on the ground for extensive periods at controlled speeds and temperatures. This results in the consumption of substantial amounts of fuel plus work time for maintenance personnel and downtime for the aircraft. With the full authority EEC, none of these costs is experienced.

The fault-sensing, self-testing, and correcting features designed into the EEC greatly increase the reliability and maintainability of the system. These features enable the system to continue functioning in flight and provide fault information that is used by maintenance technicians when the aircraft is on the ground. The modular design of the electronic circuitry saves maintenance time because circuit boards having defective components are quickly and easily removed and replaced.

Because of the need to control, many factors involved in the operation of modern high bypass turbofan engines, an electronic Engine control system has been developed that prolongs engine life, saves fuel, improves reliability, reduces flight crew work load and reduces maintenance costs. There are two type of E.E.C.

1. Supervisory EEC
2. Full authority EEC

Supervisory EEC includes a computer that receives information regarding various engine operating parameters and adjusts a standard Hydromechanical F.C.U. to obtain the most effective engine operation. The hydromechanical unit responds to EEC commands and accordingly performs the function necessary for engine operation and protection. It controls engine thrust unit, E.G.T. and R.P.M. only, rest all function is done by F.C.U.

#### **Full authority digital electronic control (FADEC).**

The full authority digital electronic control, controls the complete operation. Is a system that receives all the necessary data for engine operation and develops the commands to various actuators to control the engine parameters within the limits required for most efficient engine operation. This type of system is employed on advanced technology engines. such as pratt & whitney series 2000 & 4000.

The full authority digital electronic control replaces previous Hydromechanical unit, producing significant savings by precise and uniform control as power setting and other critical engine operating functions, the control does not employ any Hydromechanical computation elements.

A full authority performs all functions necessary to operate a turbofan engine efficiently & safely in all modes such as :

- (a) Starting
- (b) Accelerating
- (c) Deaccelerating
- (d) Speed governing, compressor vane and bleed scheduling
- (e) Engine operating and rating data, fault detection.

It receives data from Aircraft and engine systems, provides data for A/C systems and issues commands to engine control actuators.

This is a dual channel unit having a cross talk capability so that either channel can utilise data from the other channel. This provision greatly increases the reliability to the extent that the system will continue to operate effectively even though a number of faults may exist. Channel 'A' is the primary channel, channel 'B' is secondary or back up channel.

The pilot sets the power by setting the thrust lever position. The FADEC uses the thrust lever position to determine the commanded thrust setting parameters and modulates fuel flow to make the actual and commanded values equal. The FADEC system reduces the crew work load, control system costs and extends engine life. In addition the EEC System provides improved engine fuel efficiency and allows improved integration & coordination of engine control and Aircraft system.

The benefit of employing FADEC

1. Reduced crew work load.
2. Reduced fuel consumption.
3. Increased reliability & improved maintainability
4. Controls system cost
5. Extends engine life

Flt. crew work load is decreased because the pilot utilises the EPR gauge to set engine thrust correctly.

To set the thrust, the pilot only has to set the throttle lever angle to a position that results in alignment as EPR command from the EEC with the reference indicator that is positioned by the thrust management computer. The EEC will automatically accelerate or deaccelerate the engine to that EPR level without the pilot having to monitor the EPR gauge.



**Reduced fuel consumption** is maintained because the EEC controls the engine operating parameters so that maximum thrust is obtained for the amount of fuel is consumed. In addition the ACC (automatic clearance control) system ensures that compressor & turbine blade clearance are kept minimum thus reducing pressure losses due to leakage at the blade tips. Engine trimming is eliminated by the use of full authority EEC.

The fault sensing, self testing and correcting features designed into EEC greatly increases reliability and maintainability of the system. These features enable the system to continue functioning in flight provide fault information that is used for maintaining the aircraft on ground by technicians.

The modular design of the electronic circuitry saves maintenance time because circuit boards having defective components are quickly and easily removed and replaced.

The full authority EEC system assists in engine maintenance through its internal diagnostic capability which is able to detect faults and generates maintenance message that identify which control system component need to be repaired. The FADEC system will allow the same basic engine configuration to produce from 50000 lbs. (222 400N) to over 70000 lbs (311 360N) as thrust simply by changing the data entry plug for the control and the data plate for the engine.

### Speed and temperature control amplifiers

The speed and temperature control amplifier receives signals from thermocouples measuring E.G.T. and from speed probes sensing L.P. and in some cases, I.P. shaft speeds ( $N_1$  and  $N_2$ ). The amplifier basically comprises speed and temperature channels which monitor the signals sensed. If either  $N_1$ ,  $N_2$  or E.G.T. exceed pre-set datums, the amplifier output stage is triggered to connect an electrical supply to a solenoid valve or a variable restrictor which override the F.F.R. and cause a reduction in fuel flow. The limiter will only relinquish control back to the F.F.R. if the input conditions are altered (altitude, speed, ambient temperature or throttle lever position). The limiter system is designed to protect against parameters exceeding their design values under normal operation and basic fuel system failures.

### Input Signal From A/C to EEC

Throttle Resolve Angle  
(Which Tells EEC the Throttle Position)  
Service Airbleed Airstatus

Aircraft Altitude

Total Air Pressure Information is obtained from Air data Computer as well as  $P_{12}/T_{12}$  probes in the engine inlet.

Total Air Temperature

### OUTPUT FROM THE ENGINE TO EEC

Overspeed Warning  
Fuel Flow Rate  
Electric power for EEC  
High pressure rotor ( $N_2$ ) speed  
Rotor vane Angle Feed Back  
Position of 2.5 Airbleed Proximity Sw.  
Air/Oil Cooler Feedback  
Fuel Temperature  
Oil Temperature  
Automatic Clearance Control (ACC)  
TCA Position  
Engine Tail Pipe Pressure (P-4.9)  
Burner Pressure (Pb)  
Engine Inlet Total Pressure ( $P_{12}$ )  
Low Pressure Rotor ( $N_1$ ) Speed  
Engine Inlet Total Temperature ( $T_{12}$ )  
Exhaust Gas Temperature (EGT. OR T4.9)  
Sensors installed in the engine provide the EEC with measurements of temp. pressure and speed these data are used to provide automatic. Thrust rating control, engine life protection cover speed, over heat, over pressure)  
Transient control and engine starting.

### OUTPUT FROM EEC TO ENGINE

Fuel Flow, Torque Motor Command  
Stator angle torque motor command  
Air/Oil Cooler valve command  
2.5 Airbleed torque motor command  
ACC Torque Motor Command  
Oil Torque Motor Command  
Breather Ejector command  
TCA Command

The actuators that must provide feed back to EEC are equipped with linear variable differential transformer (LVDTs) to produce the required signals

### Trimming & Adjustment

Trimming of Turbine engine is the process of adjusting the fuel control unit so that engine will produce its rated thrust at the designated R.P.M. The thrust is determined by measuring the Engine Pressure Ratio. Which is the ratio of turbine discharge pressure to engine inlet pressure.  $P_{17}/P_{12}$

Gas turbine engine with digital computer controlled fuel system does not require trimming because trimming adjustments are made automatically by the control computer.

The engine speed ( $N_2$ ) which is required for the engine to deliver rated thrust is stamped on the engine data plate or recorded on the engine data sheet of the engine "Log book".

Engine trimming is required from time to time because of changes that take place during the life of the engine. Dust and other matters will adhere to surfaces of compressor rotor blades/ stator vanes and leads to a slight resistance to

Airflow. Erosion of Leading edges of blades & vanes caused by dusts, sands and other materials, changes the characteristics and performance of the compressor. The turbine blades and vanes which are exposed to very high temperatures are subjected to corrosion, erosion and distortion. All the mentioned factors tend to cause the engine thrust to decrease over a period of time. Therefore trimming is necessary to restore the rated performance of the engine.

When an engine indicates high exhaust gas temperature (EGT) for a particular EPR, it means that engine is out of trim.

The following general principles for trimming are

1. Head the Airplane to wind (velocity should not be more than 20 M.P.H.)
2. Area around engine is neat & clean & free from loose items.
3. Install calibrated instruments required for trimming ( $P_{t7}$  gage or EPR)
4. Calibrated tachometer (for  $N_2$  RPM)
5. Install a part throttle stop on fuel control trim stop.
6. Record ambient temperature and barometer pressure.
7. Start engine and operate at idle RPM and stabilize the parameters.
8. Operate engine on trim speed, for about 5 minutes to stabilize it.



# CHAPTER - 8

## CONSTRUCTION AND OPERATION OF PROPELLERS

### GENERAL

A propeller is a means of converting engine power into propulsive force. A rotating propeller imparts rearward motion to a mass of air, and the reaction to this is a forward force on the propeller blades.

Each propeller blade is of aerofoil cross-section. As the blade moves through the air, forces are produced, which are known as thrust and torque, and which may be regarded as roughly equivalent to the forces of lift and drag produced by an aircraft wing. Thrust is the propulsive force, and torque the resistance to rotation, or propeller load. The magnitude of the thrust and torque forces produced will depend on the size, shape and number of blades, the blade angle, the speed of rotation, the air density and the forward speed.

Since each blade is of aerofoil cross-section, thrust will be produced most efficiently at a particular angle of attack,

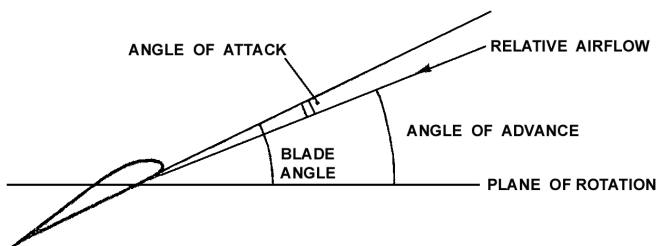

Fig. 8.1. Showing propeller terms.

that is the angle between the chord line at a particular blade section and the relative airflow. This angle varies both with operating conditions and with the design camber of the blade sections, but for a given blade and given in flight condition, it will be found to be relatively constant along the length of the blade. The rotational speed of particular cross-section of a blade will increase with its distance from the axis of rotation, and, since the forward speed of all parts of the blade is the same, the relative airflow will vary along the blade, and it is, therefore, necessary to provide a decreasing blade angle from root to tip. The various terms relating to propeller operation are illustrated in fig. 8.1. This is a simplified diagram omitting inflow angles for clarity, but in practical designs these angles can not be ignored.

The geometric pitch of a propeller is the distance which it should move forward in one revolution without slip; it is equal to  $2\pi r \tan\theta$  where  $r$  is the radius of the particular cross section and  $\theta$  is the blade angle at that point. Fixed pitch propellers are usually classified by their diameter and pitch, the pitch being related to the blade angle at 3/4 radius, or other nominated station.

Centrifugal, bending, and twisting forces act on a propeller during flight, and can be very severe at high rotational speeds. Propellers must be both strong enough to resist these forces, and rigid enough to prevent flutter. The main forces experienced are as follows :-

- a) Centrifugal forces which induce radial stress in the blades and hub, and, when acting on material which is not on the blade axis, also induce a twisting moment. Centrifugal force can be resolved into two components, in the plane of rotation one is a radial force parallel to the blade axis, and the other a force at  $90^\circ$  to the blade axis; the former produces radial stress, and the latter tends to turn the blade to a finer pitch. The turning effect is referred to as centrifugal twisting moment, and is illustrated in figure 8.2; the wider the blade, the greater will be the twisting moment.
- b) Thrust forces which tend to bend the blades forward in the direction of flight.
- c) Torque forces which tend to bend the blades against the direction of rotation.

d) Air loads which normally tend to oppose the centrifugal twisting moment and coarsen blade pitch.

The diameter of a propeller, and the number and shape of its blades, depend on the power it is required to absorb, on the take-off thrust it is necessary to produce, and on the noise-level limits which have to be met. High tip speeds absorb greater power than low tip speeds, but if the tip speed approaches the speed of sound, efficiency will fall, and this consideration limits practical diameter/ rotational speed combinations. High tip speed is also the main source of propeller noise. Large diameters normally result in better performance than small diameters, and blade area is chosen to ensure that blade lift coefficients are kept in the range where the blade sections are efficient. Wide chord blades and/or large diameters lead to heavy propellers; increase in number of blades increases cost but reduces noise. The design of any propeller is, therefore, a compromise between conflicting requirements, and the features

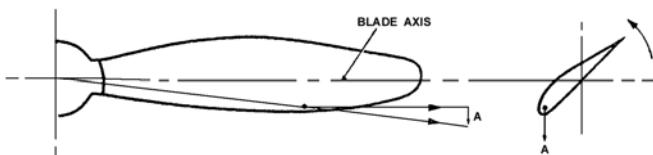

Fig. 8.2. Centrifugal twisting moment.

which are given prominence will vary from one application to another. Small two-bladed propellers, of suitable profile, are satisfactory for low-powered piston engines, but for high-powered piston or turbine engines, three, four, or five bladed, or contra-rotating, propellers are used, and are driven through a reduction gear to enable high engine power to be used at efficient propeller speeds.

### **PROPELLERBALANCE**

A propeller is a rotating mass, and if not correctly balanced can produce unacceptable vibration. An unbalanced condition may be caused by uneven weight distribution, or by uneven air loads or centrifugal forces on the blades when the propeller is rotating. Even weight distribution is known as static balance; this is checked by mounting the propeller on a shaft between knife edges; or by use of a single plane precision balancing machine. An unbalanced condition can be corrected by adding weight to the lighter blade (s) and/or removing weight from the heavier blade (s). Material may easily be removed from wooden propellers, but metal propellers are usually balanced by attaching weights to the blade hub or by adding lead wool to the hollow blade roots. If there are significant differences in form or twist between the blades on a propeller, vibration can result because the thrust and or torque produced by the blades is uneven. Procedures for evaluating such differences, and for achieving aerodynamic balance, are often available for large propellers. In their absence, careful checking of the blade profiles and adjustment of any deviations, may often eliminate vibration. It is possible for a propeller to be in perfect static and aerodynamic balance, but still suffer from dynamic unbalance when rotating. The cause of such unbalance is non-symmetrical disposition of mass within the propeller, or non-symmetrical mounting of the propeller. Such unbalance can be corrected by adding balance weights, but this may be a lengthy procedure, involving repeated runs with the propeller installed on the aircraft. Propellers are balanced after manufacture, and whenever repairs, or overhaul, have been carried out, or vibration has been reported.

### **TYPESOF PROPELLERS**

The various types of propellers are described briefly in this paragraph. The construction and operation of the main types of propellers in common use.

#### **Fixed pitch propellers**

Because of its lightness, cheapness and simplicity, a fixed-pitch propeller is often fitted to a single engine aircraft. The pitch selected for any particular engine/airframe combination will always be a compromise, since the angle of attack will vary with changes in engine speed and aircraft attitude. Too coarse a pitch would prevent maximum engine power from being used during take-off and climb, and too fine a pitch would prevent economical cruising, and would lead to over speeding of the engine in a dive.

#### **Variable pitch propellers**

With this type of propeller the blade angle may be varied in flight, so that engine power may be fully utilized. Variable-pitch propellers were originally produced with two blade-angle settings; a fine pitch to enable full engine speed to be used during takeoff and climb, and a coarse pitch to enable an economical engine speed to be used for cruising. The introduction of an engine driven centrifugal governor enabled the blade angle to be altered automatically (within a predetermined range), in order to maintain any engine speed selected by the pilot, regardless of aircraft speed or attitude.

#### **Feathering propellers**

If an engine failure occurs, the wind milling propeller may cause considerable drag, and adversely affect controllability of the aircraft. In order to reduce this drag, the blades of most constant speed propellers fitted to multi-engine aircraft are capable of being turned past the normal maximum coarse-pitch setting into line with the airflow. This is known as the 'feathered' position. Feathering the propeller not only reduces drag, but also minimizes engine rotation, thus preventing any additional damage to the engine.

#### **Reversible pitch propellers**

On some aircraft, the propeller blades may be turned past the normal fine-pitch setting, to a pitch which will produce thrust in the opposite direction (reverse thrust). On selection of reverse pitch by the pilot, the blades may be turned to a fixed reverse-pitch angle, but on some installations the pilot has control of blade angle, and can select any angle within a given range on each propeller individually, Reversible-pitch propellers provide braking during the landing run, and facilitate aircraft ground manoeuvring.

### **FIXEDPITCHPROPELLERS**

Fixed-pitch propellers normally have two blades, and are manufactured from either wood or aluminium alloy; they are generally only fitted to single-engine light aircraft.

#### **Wooden propellers**

Wooden propellers are made up from a number of planks glued together. The wood used is usually either birch or mahogany, and is specially selected and seasoned for the purpose. After gluing and a further short seasoning period to equalise moisture content in the planks, the block is cut to shape and finished. An abrasion resistant coating of either canvas or cellulose is applied to the blades, and a metal sheath is normally screwed on to the leading edges and blade tips to protect the wood from being damaged by stones. The propeller is then given several coats of varnish or cellulose paint to protect it from atmospheric conditions.

If the engine shaft has an integral flange, the propeller is clamped between this flange and a separate steel faceplate. If the shaft is splined, the propeller is mounted on a steel hub, which is internally splined to fit the shaft and has an integral rear flange an detachable front flange between which the propeller is mounted. In either case, a large clamping area is required so as to minimize damage to the wood fibres when the attachment bolts are tightened. Hubs fitted to parallel splined shafts are mounted between a front and rear cone, the purpose of which is to ensure that the propeller is concentric with the shaft. The shaft is threaded to receive a large nut, which is tightened against the front face of the front cone. Hubs fitted to tapered shaft are similarly attached, but may not be mounted on cones.

### Metal propellers

Metal propellers are usually aluminium alloy forging, and are anodised and painted for protection. They are usually bolted directly on to a shaft with an integral flange, but if they are fitted to a splined shaft they are mounted on a hub which is similar to that used for wooden propellers, but without a front flange.

### VARIABLE PITCH PROPELLERS

Variable-pitch propellers consist of a number of separate blades mounted in a central hub, and a mechanism to change the blade angle according to aircraft requirements. The blades and hub are often aluminium alloy forging, but the hub on a large propeller may be constructed from steel forging because of the high centrifugal forces which it has to contain. The blades are mounted in the hub in ball or tapered roller bearings, and the pitch-change mechanism is attached to the hub and connected to each blade through rods, yokes or bevel gears. Operation and control of the pitch change mechanism varies considerably, and three main types are discussed in this paragraph.

### Single acting propellers

A single-acting propeller is illustrated in fig. 8.3 it is a constant-speed feathering type, and is typical of the propellers fitted to light and medium sized twin-engine aircraft. A cylinder is bolted to the front of the hub, and contains a piston and piston rod which move axially to alter blade angle. On some propellers, oil under pressure, fed through the hollow piston rod to the front of the piston, moves the piston to the rear to turn the blades to a finer pitch; on other propellers the reverse applies. When oil pressure is relieved, the counterweights and feathering spring move the piston forward to turn the blades to a coarser pitch. Counterweights produce a centrifugal twisting moment but, because they are located at 90 degree to the chord line, they tend to move the blades to a coarser pitch. Counterweights must be located far enough from the blade axis, and must be heavy enough to overcome the natural twisting moment of the blade, but since weight and space are limiting factors, they are generally only used with blades of narrow chord.

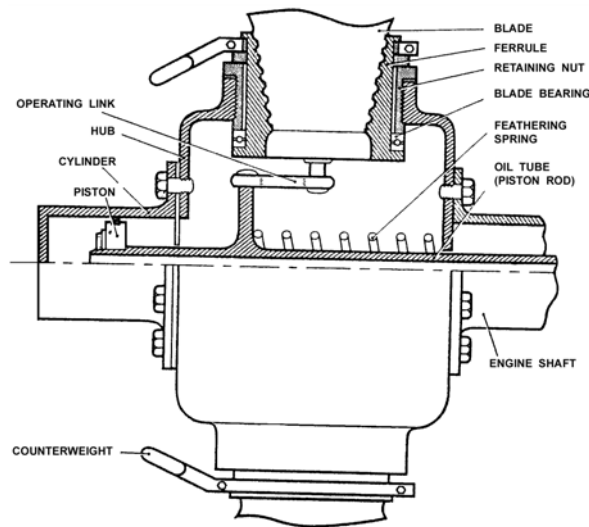

Fig. 8.3. Single acting propellers.

### Propeller Control

Blade angle is controlled by a constant-speed unit which comprises a centrifugal governor, a governor valve, and an oil pump to boost engine oil pressure sufficiently for the operation of the propeller control mechanism. The governor is driven from the engine shaft, and movement of the governor weight under centrifugal force is opposed by a control spring, the loading of which is set by means of the pilot's control lever. The position of the governor valve is determined, therefore, by engine speed and the force exerted by the spring; when these forces balance, the oil line to the propeller is blanked off, and oil is trapped in the cylinder of the pitch change mechanism.

- a) When the pilot's control lever is set to the maximum rev/min position, and the throttle is at a low power setting, the governor valve will be fully down, and oil from the pump will be directed through the hollow piston rod to turn the propeller blades to fully fine pitch. As the throttle is opened and rev/min are increased, centrifugal force on the governor weights will raise the valve, until a position is reached where maximum rev/min are obtained and the oil line to the propeller is blanked off. Any further increase in power will tend to increase rev/min and result in the governor valve being lifted; oil will drain from the propeller and produce a coarser blade pitch to maintain the specified maximum rev/min.
- b) During flight, rearward movement of the pilot's control lever will reduce control spring loading, and allow the governor weights to lift the valve; this will result in a coarser blade angle, and the increased load on the engine will reduce engine speed until the spring force is balanced by centrifugal force on the governor weights. Forward movement of the pilot's control lever will increase spring loading, and result in a finer propeller pitch and higher engine speed.
- c) If propeller load decreases in flight, or power is increased, the engine will begin to speed up, the governor weights will raise the valve, and propeller pitch will coarsen to maintain the set engine speed; conversely an increase in propeller load, or a decrease in engine power, will result in a finer propeller pitch, to maintain the set engine speed.

Feathering is accomplished by moving the pilot's control lever to the appropriate position, which is normally obtained by moving the lever through a gate in the quadrant. This action raises the governor valve fully, allowing oil to drain from propeller, and the blades to turn to the fully coarse (feathered) position under the action of the counterweights and feathering spring.

In order to unfeather the propeller, a separate source of oil under pressure is required; on light aircraft this is usually provided by an accumulator which is charged during normal operation. To unfeather, the pilot's control lever is moved into the constant speed range, thus lowering the governor valve, and the unfeathering button is pressed, releasing oil from the accumulator and allowing it to flow to the propeller. This action commences unfeathering, and once the propeller starts to windmill the normal oil supply completes the operation.

When the engine is stopped on the ground, oil pressure in the cylinder is gradually relieved by leakage through the constant speed unit (CSU), and this would enable the propeller blades to turn to the feathered position under action of the feathering springs. This condition would result in unacceptable loads on the engine during starting, and a centrifugal latch is fitted to prevent forward movement of the propeller piston when the engine is stopped. Fig. 8.5. below shows the operation of a centrifugal latch; it is disengaged by centrifugal force at all speeds above ground idling, thus enabling the propeller to function normally during flight, but below this speed centrifugal force is overcome by the return spring, and the piston can only move forward a short distance, equivalent to approximately 5° of blade angle. When the engine is started, oil pressure builds up to move the blades to fully fine pitch, and centrifugal force disengages the latch.

Because of the predominance of single-acting propellers on light aircraft, only a simple propeller has been described. However, there is a wide variety of propeller/engine installations, some of the safety features attributed to double acting propellers will also be found on particular single-acting propellers.

### DOUBLE-ACTING PROPELLER

This type of propeller is normally fitted to larger engines and, because of engine requirements, is more complicated than the propellers fitted to smaller engines. Construction is similar to that of single-acting propeller, the hub supporting the blades, and the cylinder housing the operating piston. In this case, however, the cylinder is closed at both ends, and the piston is moved in the both directions by oil pressure. In one type of mechanism, (Fig. 8.6.) links from the annular piston pass through seals in the rear end of the cylinder, and are connected to a pin at the base of each blade. In another type of mechanism, the piston is connected by means of pins and rollers to a cam track and bevel gear, the bevel gear meshing with a bevel gear segment at the base of each blade; axial movement of the piston causes rotation of the bevel gear, and alteration of blade angle. Operating oil is conveyed to the propeller mechanism through concentric tubes in the bore of the engine reduction gear shaft.

### NORMAL OPERATION

In a turbo-propeller installation the power control lever is often connected to both the fuel control unit and the propeller

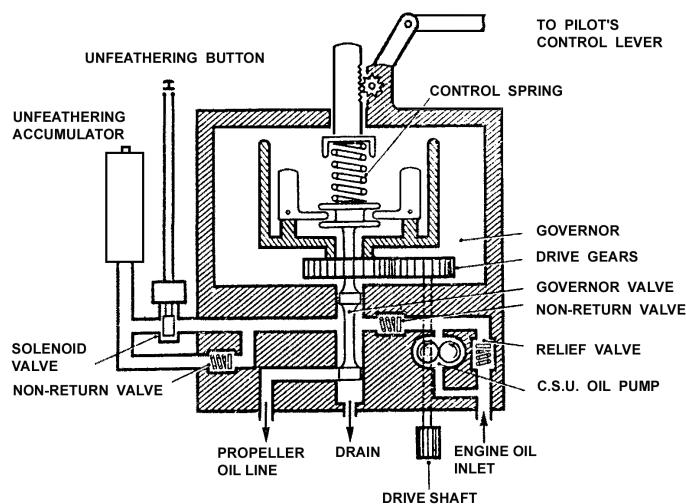

Fig. 8.4. Constant Speed Unit.

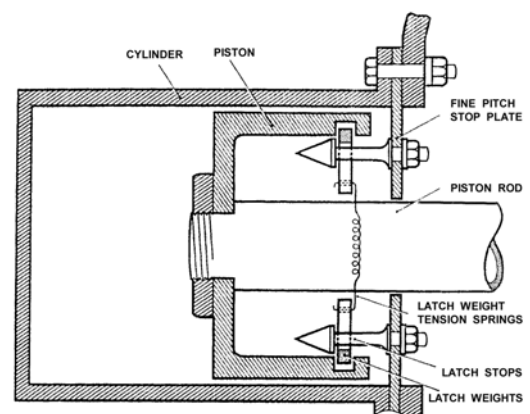

Fig. 8.5. Centrifugal latch.

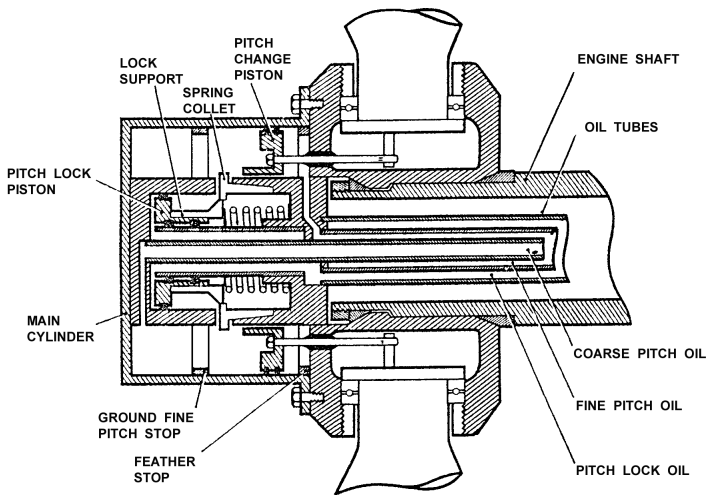

Fig. 8.6. Double acting propeller.

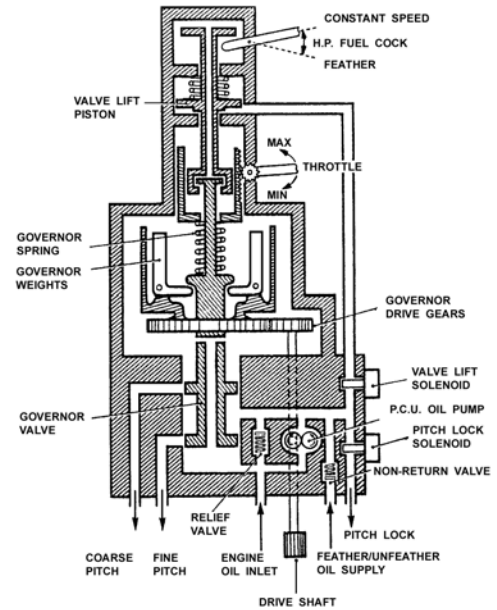

Fig. 8.7. Propeller control Unit.

control unit (PCU), so that fuel flow and engine speed are selected at the same time. The PCU is basically CSU as illustrated in Fig. 7, but the PCU includes a number of additional features. Constant speed operation is controlled in a similar manner to that on the single-acting propeller; the governor weights opposing control spring force to raise or lower the governor valve, and to supply oil to the appropriate side of the pitch change piston, whenever engine speed varies from the speed selected. Fig. 8.7 illustrates the PCU.

- In the 'on speed' condition, centrifugal force on the flyweights balances the force of the control spring, and the governor valve traps oil in both sides of the pitch change cylinder.
- In the 'under speed' condition, control spring force is greater than the centrifugal force on the flyweights, and the governor valve is lowered, supplying oil to the rear of the pitch change cylinder, and providing a drain for oil from the front of the cylinder. Blade angle decreases, and the engine speeds up until centrifugal force on the flyweights balances the force of the control spring, and the governor valve is returned to the 'on speed' condition.
- In the 'overspeed' conditions, control spring force is less than the centrifugal force on the flyweights, and the governor valve is raised, directing oil to the front of the pitch change cylinder, and providing a drain for oil in the rear of the cylinder. Blade angle increases, and the engine speed decreases because of the added load, until the flyweights and control spring are once more in balance.

### FINE PITCH STOPS

During starting and ground running, a very fine propeller pitch may be required, to minimize propeller load, and to prevent engine overheating; however, during flight, this very fine pitch would lead to engine over speeding, and excessive drag if the PCU were to fail. To cater for both these requirements, the pitch change piston on the type of propeller illustrated in figure 6 is provided with two fine pitch stops, the flight fine pitch stop being withdrawn for starting and ground operations. The flight fine pitch stop is in the form of a spring collet, the prongs of which are designed to spring inwards. When the collet is operating as a stop, the pitch-lock piston is held in the forward position by a spring, forcing the spring collet open, and preventing the pitch change piston from moving forward further than the flight fine pitch position. When ground fine pitch is required, a solenoid in the PCU is energized (normally by operation of both a stop withdrawal lever and a throttle-operated switch) and oil pressure is ducted through the third oil line to the front of the pitch lock piston; as the piston moves rearwards, support for the collet is withdrawn and the prongs spring inwards, allowing the pitch change piston to move fully forward, to the ground fine pitch position. The pitch lock solenoid is disarmed when the throttles are moved forward for takeoff, and, when the propeller has coarsened in to the constant speed range, the pitch lock piston moves forward under spring pressure and opens the spring collet to form the flight fine pitch stop.

NOTE: The term 'pitch lock' is used, in the above paragraph, to describe a means of holding the fine pitch stop in a prescribed position. Some manufacturers use the term to describe a device which locks the blades at whatever angle they happen to be, should failure of the pitch change mechanism occur.

- The entire power-unit and the aircraft must be safeguarded in the event of the failure of the pitch-lock unit to operate, and a safety system is incorporated in the PCU. If, during flight, the propeller blades move to a pitch finer than flight fine pitch, a switch fitted to one blade closes, and completes the circuit through an isolating switch to a solenoid in the PCU. This solenoid directs oil pressure to a valve-lift piston, which lifts the governor valve and directs oil to the front of the pitch change piston. This action coarsens the propeller blade angle,

and breaks the circuit to the valve-lift solenoid. If the pitch-change piston does not latch over the spring collet as it moves rearwards, the sequence will be repeated as the blades fine-off past flight fine pitch again. An isolation switch prevents operation of this safety system when ground-fine pitch is purposely selected.

### **FEATHERING**

Facilities for the manual feathering of the propeller are provided on all large piston and turbo-propeller engines. With some turbo-propeller installations, however, the drag from a wind milling propeller in the fine pitch could be very dangerous, particularly with a twin engine aircraft, and for these aircraft automatic feathering is also provided.

- (a). Manual feathering of the propeller on a piston engine is normally carried out by movement of the propeller control lever to the 'feather' position, and operation of the feathering pump. These actions raise the governor valve, and supply oil under pressure to the appropriate side of the pitch-change piston. On a turbo-propeller installation, manual feathering is carried out by an interconnection between the PCU and the high pressure fuel cock. When the fuel cock is moved to the 'feather' position, linkage to the PCU lifts the governor valve independently of governor control, and oil is directed to the front of the pitch change piston to turn the blades fully coarse. Since the oil pump in the PCU is driven by the engine, the oil supply may be insufficient to feather the propeller completely, and the operation of the electrically-driven feathering pump may be necessary.
- (b). Automatic feathering is initiated by means of a torque switch. Whenever the power levers are positioned above the idling range, and the engine torque falls below a specified amount, the torque switch closes and completes a circuit to the feathering pump and the valve-lift solenoid in PCU. The solenoid direct oil to the valve lift piston which raises the governor valve, and opens the oil ports from the feathering pump to the front of the pitch change piston, thus feathering the propeller.

### **UNFEATHERING**

On turbo-propeller engines, when the high pressure fuel cock is open and the power levers closed, the governor valve is in a suitable position to direct oil from the feathering pump to the rear of the pitch change piston. Selection of feathering pump switch (which is often incorporated in the fire control handle), supplies oil to the PCU and thence to the propeller, and activates the engine ignition system. When the propeller blades have turned from the feathered position, the airstream commences to wind will the propeller and rotate the engine, and normal oil pressure builds up to complete the unfeathering operation.

### **REVERSING**

In a reversing propeller, the propeller mechanism includes a removable ground fine pitch stop, which enables the propeller to fine-off to a negative pitch when certain actions have been taken and certain condition are fulfilled. Various safeguards are incorporated to prevent selection during flight. The means of achieving negative pitch vary considerably, but operation of a typical hydraulically operated propeller is described in the following paragraphs.

- (a) Electrical control is exercised by throttle-mounted switches, weight contact switches on the landing gear, and a master switch or lever to arm the circuit. With the throttle levers closed beyond normal idling to a datum position, 'reverse' selected, and the weight of the aircraft on its wheels, electrical power is supplied to a pitch-stop withdrawal solenoid, and oil pressure is directed to withdraw the fine-pitch stop and move and pitch-change piston forward to the reverse stop, where it is held by hydraulic pressure. Operation of the 'reverse' lever also changes the sense of operation of the throttle levers., which are pulled further back to increase power in reverse pitch.
- (b) Indication of stop withdrawal, and movement of the blades to negative pitch, is provided by hub-mounted switches, which illuminate appropriate warning lamps on the flight deck.
- (c) Re-selection of positive blade angle is achieved by moving the throttle into the normal idling range, and by moving the master lever out of the reverse position. Oil is ducted to the front of the pitch change piston, and the blades move to a positive angle; the stop returns to normal operation once the blades have moved past the ground fine pitch angel.

### **'BETA' CONTROL**

On some gas turbine engines, a form of control known as 'beta', or blade angle control, is used or ground operations, and may be applied to either, single-acting or double-acting propellers. With this system, the throttle (usually known as power lever) operate in a gated quadrant. During flight these levers cannot be closed below the 'flight idle' gate, and the CSU operates normally to maintain any pre-selected propeller speed, In the ground idling and reversing range, the power lever control propeller speed, and the governor mechanism is overridden. An overspeed sensor, and mechanical pitch stop, prevent operation in the ground (fine pitch) range during flight. In the beta range, the pitch stop is withdrawn, and movement of a power lever rotates a setting cam in the associated CSU, which raises or lowers the governor valve according to whether a coarser or finer pitch is required. A mechanical feedback mechanism, operated by linkage from the propeller blades, resets the governor valve via a follow-up cam, and pitch change ceases when the angle scheduled by the power lever is achieved.

### **ELECTRICALLY OPERATED PROPELLERS**

As with other types of variable-pitch propellers, a hub is mounted on the engine reduction gear shaft, the individual blades are fitted into the hub, and the pitch change mechanism is fitted to the front of the hub. In this type, however, the pitch change mechanism consists of a reversible electric motor, driving a bevel gear through a gear train with a very high reduction ratio. The bevel gear meshes with a bevel gear segment attached to the root of each blade, and, when



rotates, turns the blades to alter propeller pitch. Electric power to the motor is provided through a brush and slip-ring arrangement at the rear of the hub. A motor brake is provided to prevent overrun, and normally consists of two friction discs, one fixed to the rotating motor shaft, and the other keyed to the stationary motor casing. The brake is applied (discs held together) by spring pressure, and released by means of a solenoid whenever a pitch change is initiated.

Some electrically operated propellers are controlled by an engine-driven CSU, and switches are also provided which enable propeller pitch to be controlled manually. The CSU is similar to those fitted to hydraulically operated propellers, but the governor valve supplies oil to the appropriate side of a piston contained in the CSU, which is connected to the central contact of a switch unit. Movement of this piston in either direction completes a circuit to the pitch change motor, and alters blade angle as required.

On some multi-engines aircraft an electrical control system is used. A single propeller pitch level controls the speed of a master electric motor, which is used as a reference for engine speed, and which drives the stator of a contactor unit for each engine. Each engine drives an alternator, which supplies three-phase alternating current to the stator winding of the appropriate contactor, the frequency being proportional to engine speed. During operation, a magnetic field is built up round the stator with a phase rotation opposite to that of the stator. If the stator speed and alternator speed are the same, the magnetic field will, therefore, be stationary; any variation in alternator speed will result in rotation of magnetic field, the direction of rotation depending on whether the alternator is rotating faster or slower than the stator. Rotation of the magnetic field influences a concentric rotor, which rotates with it, and closes a pair of contacts to complete the circuit to the appropriate winding in the propeller pitch change motor. Switches are normally provided to enable pitch changes and feathering to be carried out manually.



# CHAPTER - 9

## ANTIICING OF GAS TURBINE ENGINE

### INTRODUCTION

This Chapter gives general guidance on the installation and maintenance of the thermal systems employed for the anti-icing of the air intakes of turbine engine. It should be read in conjunction with the installation drawings, Maintenance Manuals and approved Maintenance Schedules for the engine and aircraft concerned.

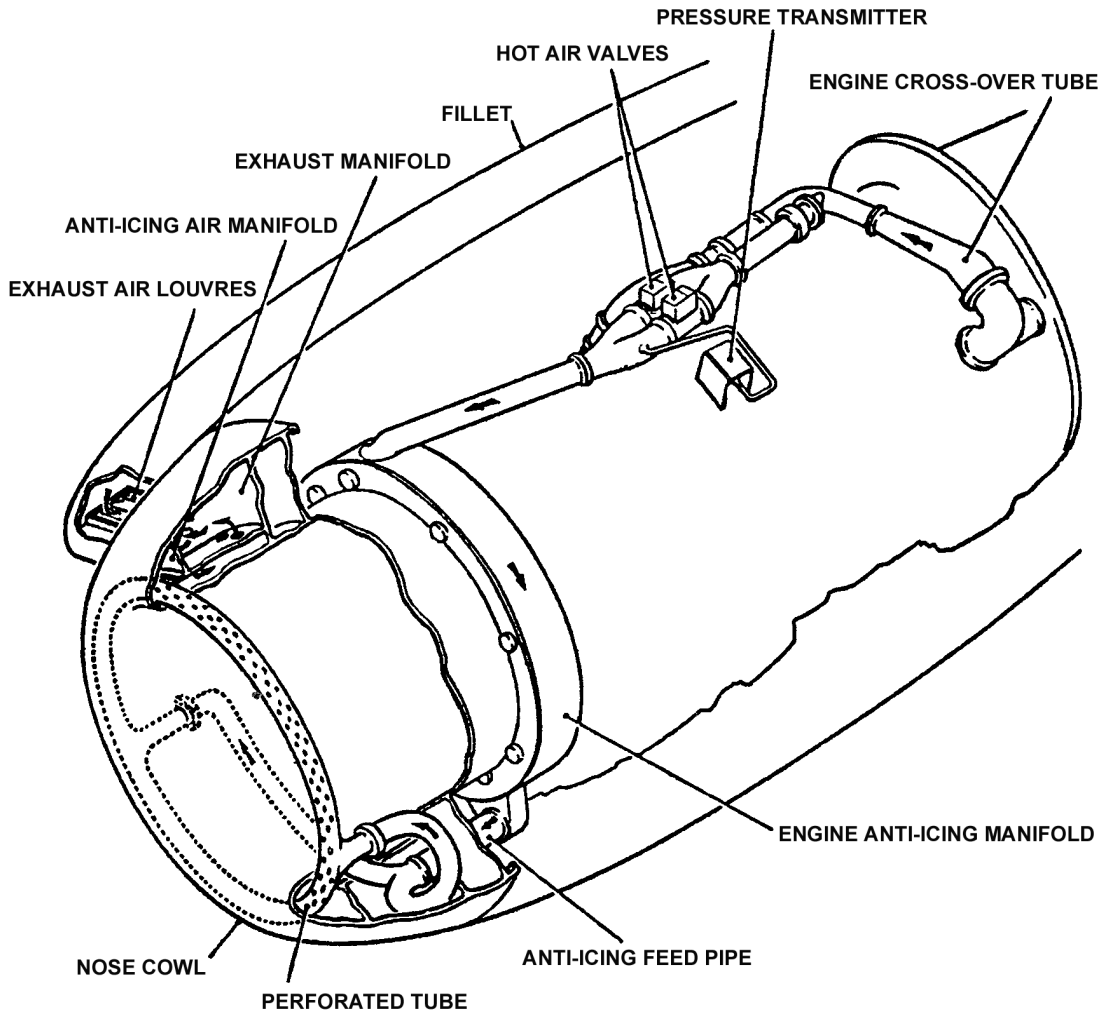

Fig. 9.1. Typical Hot Air Anti-Icing System.

### General

A gas turbine engine presents a critical icing problem and therefore requires protection against ice formation particularly at the air intake, nose bullet or fairing, and inlet guide vanes. Icing of these regions can considerably restrict the airflow causing a loss in performance and, furthermore, cause damage to the compressor as a result of ice breaking away and being ingested by the compressor. There are two thermal systems in use for air intake anti-icing; a hot air bleed system and an electrical resistance heating system, and although the latter is usually chosen for turbo propeller engines to provide protection for the propeller, there are some examples where both systems are used in combination.

### Hot Air System

In a hot air system the air is bled from the compressor and is fed via ducting into the air intake nose cowl, through the inlet guide vanes of the engine and also, in some engines, through the nose bullet. A typical system is illustrated in

Fig. 9.1. After circulating the intake cowl and guide vanes, the air is exhausted either to atmosphere or into the engine air intake. The flow of hot air is regulated by electrically operated control valves which are actuated by control switches on a cockpit panel. An air temperature control system is not usually provided in a hot air system.

### Electrical Heating System

In an electrical heating system, heating elements either of resistance wire or sprayed metal, are bonded to the air intake structure. The power supply required for heating is normally three-phase alternating current. The arrangement adopted in a widely used on turbopropeller engine is illustrated in Figure 9.2 as an example. The elements are of the resistance wire type and are formed into an overshoe which is bonded around the leading edge of the air intake cowl and also around the oil cooler air intake. Both anti-icing and de-icing techniques are employed by using continuously heated and intermittently heated elements respectively. The elements are sandwiched between layers of glass cloth impregnated with resin. In some systems the elements may be sandwiched between layers of rubber. The outer surfaces are, in all cases, suitably protected against erosion by rain, and the effect of oils, greases, etc. The power supply is fed directly to the continuously heated elements, and via a cyclic time switch unit to the intermittently heated elements and to the propeller blade elements. The cyclic time switch units control the application of current in selected time sequences compatible with prevailing outside air temperature conditions and severity of icing. The time sequences which may be selected vary between systems. For the system shown in Figure 2 the sequences are 'Fast', giving one complete cycle (heat on/heat off) of 3 minutes at outside air temperature between  $-6^{\circ}\text{C}$  and  $+10^{\circ}\text{C}$ , and 'Slow', giving one complete cycle of 6 minutes at outside air temperatures below  $-6^{\circ}\text{C}$ . An indicator light and, in some cases, an ammeter, are provided on the appropriate cockpit control panel to indicate correct functioning of the time switch circuit.

### INSTALLATION AND MAINTENANCE

Full details of the methods of installation and check necessary for the inspection and maintenance of systems and associated components will be found in the relevant aircraft and engine Maintenance Manuals and approved Maintenance Schedules; reference must therefore be made to such documents. Reference should also be made for guidance on the installation of electric cables and testing of circuits. The information given in the following paragraphs is intended only as a general guide to the installation and maintenance procedures normally required.

### Hot Air System

The installation and maintenance of components of hot air systems is, in general, a straightforward procedure which only requires checks to ensure security of attachments to appropriate parts of the aircraft structure, security of duct

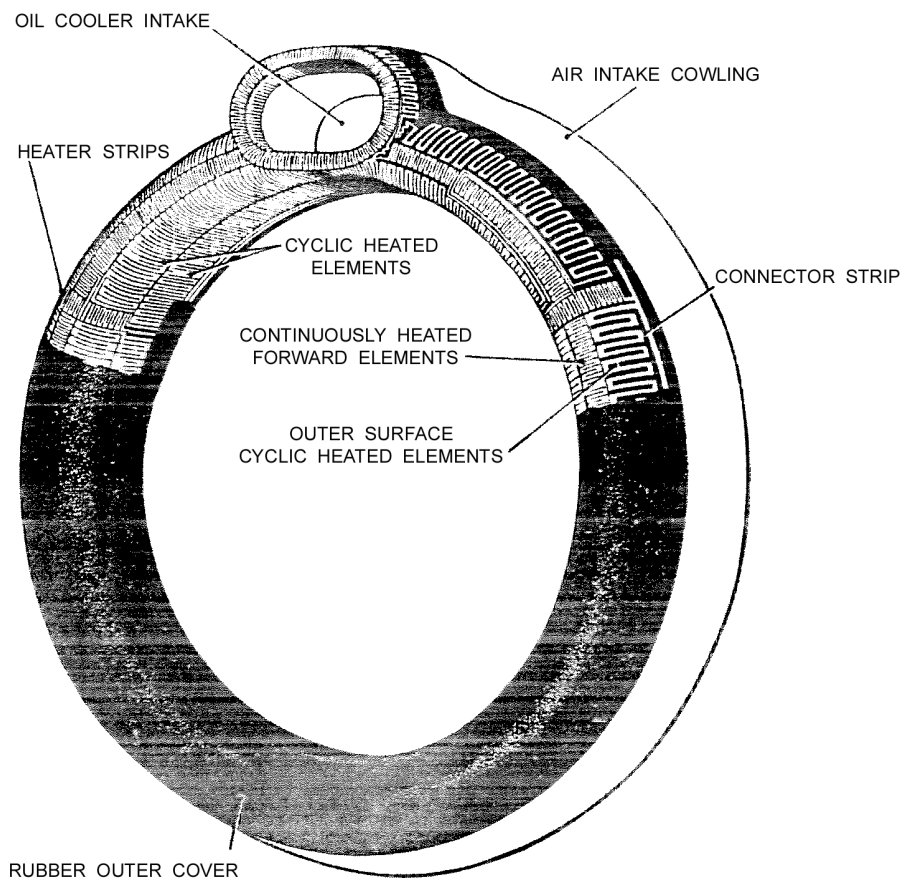

Fig. 9.2. Typical Electrical Anti-Icing System.

connections and wirelocking, where necessary. After installation of a component and at the periods detailed in the aircraft approved Maintenance Schedule, a system should be tested to ensure proper functioning and checks made for leakage at the areas disturbed. Some important aspects common to installation and maintenance procedures are given in the following paragraphs.

Ducts should be inspected externally and internally for cleanliness, signs of damage and security of end fittings.

During installation, ducts must be adequately supported at all times, and must not be allowed to hang from a joint or other component. There must be adequate clearance between ducts and adjacent structure and components.

In general, new seals should be fitted between jointing faces of end fittings of ducts and components such as control valves. This is also essential whenever a joint is broken down for any reason. The jointing faces should also be checked for excessive ovality or gapping.

Whenever possible ducting should be removed by disconnecting at a point where band-type vee-clamps are used. On some engines bolted spherical connections are employed and, unless it is absolutely necessary, the ducts should not be disconnected at these points since the connections will require special refitting.

Band-type vee-clamps should be lubricated with the dry-film lubricant specified in the Maintenance Manual and torque-tightened to the loads specified. The clearance between the flanges of fittings should be checked in order to ensure that the seal between the jointing faces of duct end fittings has been sufficiently compressed.

Expansion bellows type joints should be checked for full and free movement.

All sections of ducting should be properly aligned with each other and with other associated components. In most cases ducting passes through confined spaces and requires considerable care to ensure stress-free alignment at the joints before finally securing in place. Ducting should not be drawn into alignment by means of flange attachment devices. On some types of engine alignment is facilitated by locating a dowel in a hole. On others alignment is by means of coloured flashes painted on the ducts and components.

If a section of ducting or a component is removed and refitting is not being effected immediately, suitable blanks must be fitted to the open ends of ducts or other connections to prevent the ingress of foreign matter.

Where specified, ducts should be tested for leaks in the manner prescribed in the relevant aircraft and engine Maintenance Manuals. The test pressure and rate of leakage should not exceed the limits quoted.

NOTE: Adequate safety precautions must be taken when inspecting duct sections under pressure.

Control valves should be inspected for cleanliness, signs of damage and their insulation resistance and solenoid resistance values measured to ensure that they are within the limits specified in the Maintenance Manual. When installing valves particular care is necessary to ensure that they are positioned in correct relation to the air flow as indicated by an arrow on the body of the valve.

Cables interconnecting appropriate electrical components must be of the rating specified by the manufacturer. All connections should be checked against the relevant wiring diagrams, and plugs, sockets and terminal screws properly secured.

On completion of the installation of a duct section or component, and the periods specified in the approved Maintenance Schedule, an in-situ functional test should be carried out. Any limitations as to the duration of the test and other precautions during engine ground running, must be strictly observed. A functional test consists principally of checking the air pressure supplied to the system at a specified engine speed, and checks on the function of associated controlling and indicating devices. Such checks and tests should be performed to a prescribed test schedule.

### **Electrical Heating Systems**

In systems of this type, the overshoes are bonded to the air intake cowls, therefore removal and installation procedure are related to the cowls as combined units. The procedures are straightforward involving only the removal and refitting of setscrews which secure cowls to engine air intake casings, and the making and breaking of the electrical connections. In some cases the procedures also involve the connection and disconnection as appropriate, of fire extinguisher system spray pipes and oil cooler pipes and couplings at the rear face of the air intake cowl. Set-screws pass through steel insert and rubber bush assemblies and care should be taken to avoid losing these during removal. The bushes should be examined for wear and deterioration and renewed as necessary. Where specified, the clearance between the cowl diaphragm and engine air intake casing must be checked before finally securing the cowl, to ensure that it corresponds to the value specified in the engine Maintenance Manual. If the correct clearance cannot be obtained, the complete cowl assembly or diaphragm should be replaced by a serviceable item. Some important aspects common to inspection and maintenance procedures are given in the following paragraphs. These should be read in conjunction with the aircraft and engine Maintenance Manuals and approved Maintenance Schedules.

Cowls and electrical leads should be inspected for security and the overshoes inspected for blisters, gashes, exposure of the heating elements, signs of overheating and general deterioration.

NOTE: Overheating or a complete 'burn-out', can be caused through impact damage to the overshoe, defects in the heating elements or malfunction of the aircraft's electrical power supply to the heating elements.

The lacquer film on rubber covered overshoes should be examined for damage or deterioration and if either is evident the film should be touched-up or completely renewed as necessary, by using repair kit supplied by the relevant manufacturer.

Checks on the continuity and resistance of the heating elements, and insulation resistance checks of the complete cowl assembly, must be carried out whenever an assembly has been change or repair effected and also at the prescribed inspection periods.

NOTE: The metal or air cowls is normally anodised and it is necessary to bare a small area to effect the 'earth' connection. On completion of the electrical checks, this area must be reprotected against corrosion.

Functional testing of a complete system must be carried out at the check periods specified in the approved Maintenance Schedule, when a system malfunction occurs, after replacement of an intake cowl or a system component such as a cyclic time switch, and also after any repairs to an overshoe. A functional test consists principally of checking that heating current is applied to the heater elements at the periods governed by the operation of the cyclic time switch and, as indicated by the system indicator light, and ammeter where applicable, to the systems. Tests and checks must be performed to a prescribed test schedule paying particular attention to any limitations on system operation and engine speeds during ground running.

NOTE: The power supply control circuit is usually routed through landing gear shock-strut micro switches so that on the ground the power is automatically reduced to prevent overheating. Therefore, whenever the aircraft is on jacks, or the micro switches are otherwise rendered inoperative, power should not be applied to the heating elements.

If blisters, gashes, exposure of the heating elements, general deterioration and lack of adhesion of either rubber or glass cloth covering is evident, the covering should be carefully cut open to permit examination of the heating elements. If the elements are not fractured or cracked and the rubber or glass cloth below the elements has not deteriorated, the areas may be repaired as a minor repair.

The heating element system is made up of a number of sections or pads and if any one of the sections has been fractured due to a localised burn-out or mechanical damage, a repair can be made by welding a portion of element in the appropriate section.

NOTE: The number of repairs in a section or pad is normally limited to one since the weld causes an increase in element resistance.

The repair methods to be adopted, and the nature of the work involved, depends largely on the extent of damage and also on the type of overshoe construction, i.e. glass cloth or rubber laminate. Repair schemes are therefore devised for each type and are usually classified according to the level of the repairs required, i.e. minor repairs which can be carried out in the normal overhaul workshops, or major repairs to be carried out by the manufacturer. Full details of these schemes are given in the Maintenance Manuals and Overhaul Manuals for the relevant type of engine and reference must always be made to these documents.

An air intake cowl assembly which has been damaged or has deteriorated to an extent outside repair standards specified in the Maintenance Manuals and Overhaul Manuals should be removed and replaced by a serviceable assembly.



# CHAPTER - 10

## STORAGE OF PISTON AND GAS TURBINE AERO ENGINE

### INTRODUCTION

Under normal operating conditions the interior parts of an engine are protected against corrosion by the continuous application of lubricating oil, and operating temperatures are sufficient to dispel any moisture which may tend to form; after shutdown the residual film of oil gives protection for a short period. When not in regular service, however, parts which have been exposed to the products of combustion, and internal parts in contact with acidic oil, are prone to corrosion. If engines are expected to be out of use for an extended period they should be ground run periodically or some form of anti-corrosive treatment applied internally and externally to prevent deterioration.

The type of protection applied to an engine depends on how long it is expected to be out of service, if it is installed in an aircraft, and if it can be turned.

This Chapter gives guidance on the procedures which are generally adopted to prevent corrosion in engines but, if different procedures are specified in the approved Maintenance Manual for the particular engine, the manufacturer's recommendations should be followed.

The maximum storage times quoted in this Chapter are generally applicable to storage under cover in temperate climates, and vary considerably for different storage conditions. Times may also vary between different engines, and reference must be made to the appropriate Maintenance Manual for details.

### INSTALLED PISTON ENGINES

If it is possible to run a piston engine which is installed in an aircraft and expected to be out of service for a period of up to one month, sufficient protection will be provided by running the engine every seven days, but if the period of inactivity is subsequently extended, continued periodic ground running would result in excessive wear and the engine should be placed in long term storage. The run should be carried out at low engine speed (1000 to 1200 rev/min), exercising the engine and propeller controls as necessary to ensure complete circulation of oil, until normal working temperatures are obtained. If the engine cannot be run for any reason, the manufacturer may recommend that it should be turned by hand or motored by means of an external power supply, but generally it will be necessary to inhibit the engine as described below.

#### Long Term Storage

When a piston engine is likely to be out of service for a period in excess of one month it must be treated internally and externally with a corrosion inhibitor. The treatments described below are normally considered satisfactory for six months but this may be extended to twelve months in ideal storage conditions. At the end of this period the engine should be prepared for service, given a thorough ground run and re-protected or, alternatively, removed from the aircraft and stored as described in following paragraphs.

#### Internal Protection

##### I. American Method

- a. Drain the oil sump and tank and refill with storage oil as prescribed by the manufacturer.
- b. Run the engine at low speed (1000 to 1200 rev/min) until normal operating temperatures are obtained.
- c. Spray cylinder protective into the induction system until white smoke issues from the exhaust, then switch off the engine but continue spraying until rotation has ceased.
- d. Drain the oil sump and remove the filters.
- e. Remove the sparking plugs and spray a fixed quantity of cylinder protective into each cylinder while the engine is turned by hand. A further quantity should then be sprayed into the cylinders with the engine stationary.
- f. Fit dehydrator plugs in each cylinder and replace oil filters.
- g. Place a quantity of desiccant in the intake and exhaust and blank off all openings.

##### II. British Method

- a. Drain the oil sump and tank and refill with the storage oil recommended by the manufacturer.
- b. Run the engine at low speed (1000 to 1200 rev/min) until normal operating temperatures are obtained.
- c. Drain all oil from the system and remove filters.
- d. Remove sparking plugs and spray the specified quantity of cylinder protective into each cylinder while the piston is at the bottom of its stroke, at the same time spraying the valve springs and stems with the valves closed, and the valve heads and ports with the valves open. Also spray the valve rocker gear.
- e. Turn the engine at least six revolutions by hand, then spray half the previously used quantity of cylinder protective into each cylinder with the engine stationary.
- f. Replace oil filters and fit dehydrator plugs.
- g. Blank off all openings into the engine (intake, exhaust, breathers, etc.).
- h. Replenish oil tank to normal level with storage oil as specified.

### III. Special Requirements

- a. Coolant systems should be drained and thoroughly flushed unless an inhibited coolant is used.
- b. Fuel system components such as fuel pumps, injectors, carburettors or boost control units also require inhibiting. This is done by draining all fuel and oil as appropriate, and refilling with storage or mineral oil as recommended by the manufacturer. Blanking caps and plugs should then be fitted to retain the oil.
- c. Auxiliary gearboxes should also be inhibited. The normal lubricating oil should be drained and the gearbox refilled with storage oil.
- d. If the propeller is removed the propeller shaft should be sprayed internally and externally with cylinder protective and correct blanks fitted.

#### External Protection

Exterior surfaces of the engine should be thoroughly cleaned with an approved solvent such as white spirit, by brushing or spraying, and dried with compressed air. Any corrosion should be removed, the area re-treated in accordance with the manufacturer's instructions and chipped or damaged paintwork renewed. The following actions should then be taken :-

- I All control rods should be liberally coated with a general purpose grease.
- II Magneto vents should be covered.
- III Sparking plug lead ends should be fitted with approved transport blanks, exposed electrical connections masked and rubber components covered with waxed paper or mouldable wrap.
- IV Spray holes in fire extinguisher pipes should, if possible, be blanked off, using polythene sleeving or waxed paper suitably secured.
- V An approved preserving (normally lanolin or external air drying varnish) should be sprayed over the whole engine, in a thin even film.

#### INSTALLED TURBINE ENGINES

Installed turbine engines which are to be out of use for a period of up to seven days require no protection apart from fitting covers or blanks to the intake, exhaust and any other apertures, to prevent the ingress of dust, rain, snow, etc. A turbine engine should not normally be ground run solely for the purpose of preservation, since the number of temperature cycle to which it is subjected is a factor in limiting its life. For storage periods in excess of seven days additional precautions may be necessary to prevent corrosion.

#### Short-term Storage

The following procedure will normally be satisfactory for a storage period of up to one month.

#### Fuel System Inhibiting

The fuel used in turbine engines usually contains a small quantity of water which, if left in the system, could cause corrosion. All the fuel should therefore be removed and replaced with an approved inhibiting oil by one of the following methods:

#### Motoring Method

This should be used on all installed engines where it is convenient to turn the engine using the normal starting system. A header tank is used to supply inhibiting oil through a suitable pipe to the engine. A filter and an on/off cock are incorporated in the supply pipe, which should be connected to the low pressure inlet to the engine fuel system and the aircraft LP cock closed. After draining the engine fuel filter a motoring run should be carried out bleeding the high pressure pump and fuel control unit, and operating the HP cock several times while the engine is turning. Neat inhibiting oil will eventually be discharged through the fuel system and combustion chamber drains. When the motoring run is complete the bleeds should be locked, the oil supply pipe disconnected and all apertures sealed or blanked off.

#### Pressure Rig Method

This may be used on an engine which is installed either in the aircraft or in an engine stand. A special rig is used which circulates inhibiting oil through the engine fuel system at high pressure. The fuel filter should be drained and, where appropriate, the aircraft LP cock closed. The inlet and outlet pipes from the rig should be connected to the high pressure fuel pump pressure tapping and the system low pressure inlet respectively, and the rig pump turned on. While oil is flowing through the system the components should be bled and the HP cock operated several times. When neat inhibiting oil flows from the combustion chamber drains the rig should be switched off and disconnected, the bleed valves locked and all apertures sealed or blanked off.

#### Gravity Method

This is used when the engine cannot be turned. A header tank similar to the one used in the motoring method is required but in this case the feed pipe is provided with the fittings necessary for connection at several positions in the engine fuel system. The fuel filter should first be drained then the oil supply pipe connected to each of the following positions in turn, inhibiting oil being allowed to flow through the adjacent pipes and components until all fuel is expelled:

- a. High pressure fuel pump pressure tapping.
- b. Fuel control unit pressure tapping.
- c. Burner Manifold.
- d. Low pressure inlet pipe.

Components should be bled at the appropriate time and the HP cock operated several times when inhibiting the fuel control unit. All bleeds and apertures should be secured when the system is full of inhibiting oil.

### **Lubrication Systems**

Some manufacturers recommend that all lubrication systems (engine oil, gearbox oil, starter oil, etc.) of an installed engine should be drained, and any filters removed and cleaned, while others recommend that the systems should be filled to the normal level with clean system oil or storage oil. The method recommended for a particular engine should be ascertained from the appropriate Maintenance Manual.

### **External Treatment**

Exterior surfaces should be cleaned as necessary to detect corrosion, then dried with compressed air. Any corrosion should be removed, affected areas re-treated, and any damaged paintwork made good in accordance with the manufacturer's instructions. Desiccant or vapour phase inhibitor should be inserted in the intake and exhaust, and all apertures should be fitted with approved covers or blanks.

### **Long-term Storage**

For the protection of turbine engines which may be in storage for up to six months, the short-term preservation should be applied and, in addition, the following actions taken :-

- I. Grease all control rods and fittings.
- II. Blank-off all vents and apertures on the engine, wrap greaseproof paper round all rubber parts which may be affected by the preservative and spray a thin coat of external protective over the whole engine forward of the exhaust unit.

At the end of each successive six months storage period an installed engine should be re-preserved for a further period of storage. Alternatively, the engine may be removed from the aircraft and preserved in a moisture vapour proof envelope.

### **UNINSTALLED ENGINES (PISTON AND TURBINE)**

Engines which have been removed from aircraft for storage, or uninstalled engines which are being returned for repair or overhaul, should be protected internally, and sealed in moisture vapour proof (MVP) envelopes. This is the most satisfactory method of preventing corrosion, and is essential when engines are to be transported overseas.

A piston engine should be drained of all oil, the cylinders inhibited as described in above paragraphs, drives and inside of crankcase sprayed with cylinder protective, and all openings sealed.

A turbine engine should be drained of all oil, fuel system inhibited, oil system treated as recommended by the manufacturer, and blanks fitted to all openings.

Particular care should be taken to ensure that no fluids are leaking from the engine, and that all sharp projections, such as locking wire ends, are suitably padded to prevent damage to the envelope.

The MVP envelope should be inspected to ensure that it is undamaged, and placed in position in the engine stand or around the engine, as appropriate. The engine should then be placed in the stand, care being taken not to damage the envelope at the points where the material is trapped between the engine attachment points and the stand bearers.

Vapour phase inhibitor or desiccant should be installed in the quantities and at the positions specified in the relevant Maintenance Manual, and a humidity indicator should be located in an easily visible position in the envelope. The envelope should then be sealed (usually by adhesive) as soon as possible after exposure of the desiccant or vapour phase inhibitor.

The humidity indicator should be inspected after 24 hours to ensure that the humidity is within limits (i.e. the indicator has not turned pink). An unsafe reading would necessitate replacement of the desiccant and an examination of the MVP envelope for damage or deterioration.

After a period of three years storage in an envelope the engine should be inspected for corrosion and re-preserved.

### **INSPECTION**

Engines in storage should be inspected periodically to ensure that no deterioration has taken place.

Engines which are not preserved in a sealed envelope should be inspected at approximately two-weekly intervals. Any corrosion patches should be removed and the protective treatment re-applied, but if external corrosion is extensive a thorough inspection may be necessary.

Envelopes on sealed engines should be inspected at approximately monthly intervals to ensure that humidity within the envelope is satisfactory. If the indicator has turned pink the envelope should be unsealed, the desiccant renewed and the envelope resealed.





## CHAPTER - 11

### ENGINE INDICATING SYSTEMS (PART-I)

#### EXHAUST GAS TEMPERATURE/INTERSTAGE TURBINE TEMPERATURE SYSTEMS

The temperature of the exhaust gases is always indicated to ensure that the temperature of the turbine assembly can be checked at any specific operating condition. In addition, an automatic gas temperature control system is usually provided, to ensure that the maximum gas temperature is not exceeded.

Turbine gas temperature (T.G.T.) sometimes referred to as exhaust temperature (E.G.T. or jet pipe temperature (J.P.T.)), is a critical variable of engine operation and it is essential to provide an indication of this temperature. Ideally, turbine entry temperature (T.E.T.) should be measured; however, practical, but, as the temperatures involved this is not practical, but, as the temperature drop across the turbine varies in a known manner, the temperature at the outlet from the turbine is usually measured by suitably positioned thermocouples. The temperature may alternatively be measured at an intermediate stage of the turbine assembly, as shown in fig. 11.1.

The thermocouple probes used to transmit the temperature signal to the indicator consist of two wires of dissimilar metals that are joined together inside a metal guard tube. Transfer holes in the tube allow the exhaust gas to flow across the junction. The materials from which the thermocouple wires are made are usually nickel-chromium and nickel-aluminium alloys.

The probes are positioned in the gas stream so as to obtain a good average temperature reading and are normally connected to form a parallel circuit. An indicator, which is basically a milli voltmeter calibrated to read in degrees centigrade, is connected into the circuit fig. 11.2.

The junction of the two wires at the thermocouple probe is known as the 'hot' or 'measuring' junction and that at the indicator as the 'cold' or 'reference' junction. If the cold junction is at a constant temperature and the hot junction is sensing the exhaust gas temperature, an electromotive force (E.M.F.), proportional to the temperature difference of the two junctions is created in the circuit and this causes the indicator pointer to move. To prevent variations of cold junction temperature affecting the indicated temperature, an automatic temperature compensating device is incorporated in the indicator or in the circuit.

The thermocouple probes may be of single, double or triple element construction. Where multiple probes are used they are of differing lengths in order to obtain a temperature reading from different points in the gas stream to provide a better average reading than can be obtained from a single probe fig. 11.1.

The output to the temperature control system can also be used to provide a signal, in the form of short pulses, which, when coupled to an indicator, will digitally record the life of the engine. During engine operation in the higher temperature ranges, the pulse frequency increases progressively causing the cyclic-type indicator to record at a higher rate, thus relating engine or unit life directly to operating temperatures.

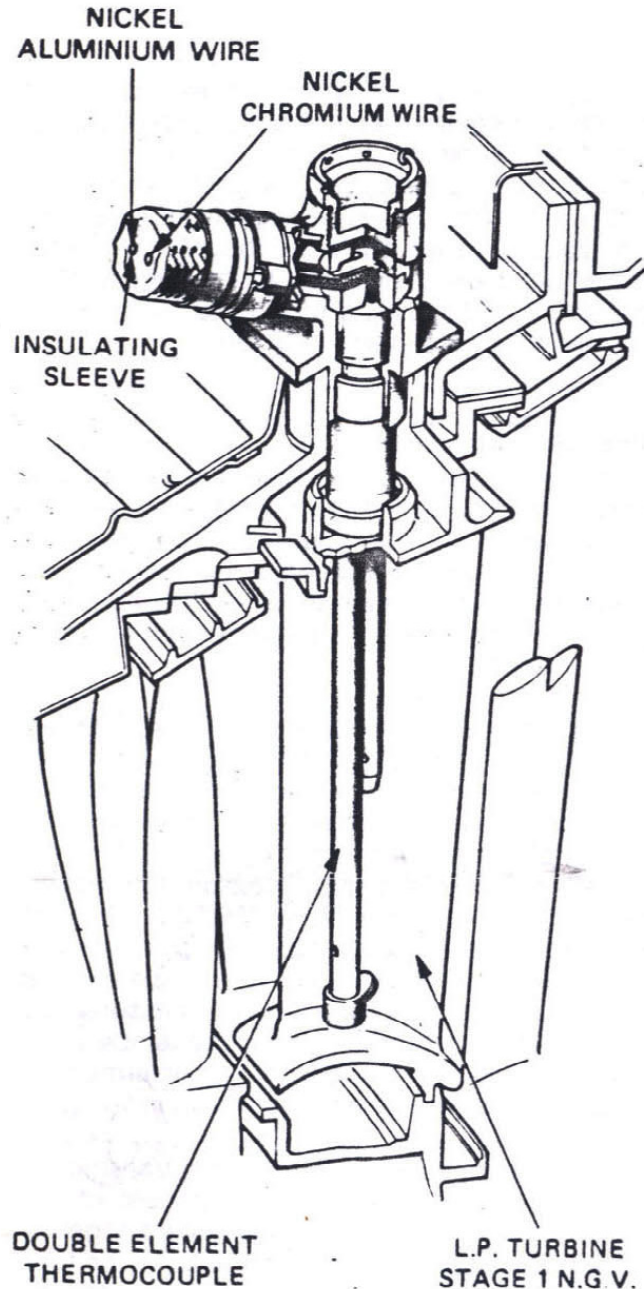

Fig. 11.1. Turbine thermocouple installation

Thermocouples may also be positioned to transmit a signal of air intake temperature into the exhaust gas temperature indicating and control systems, thus giving a reading of gas temperature that is compensated for variations of intake temperature. A typical double-element thermocouple system with air intake probes is shown in fig. 11.2.

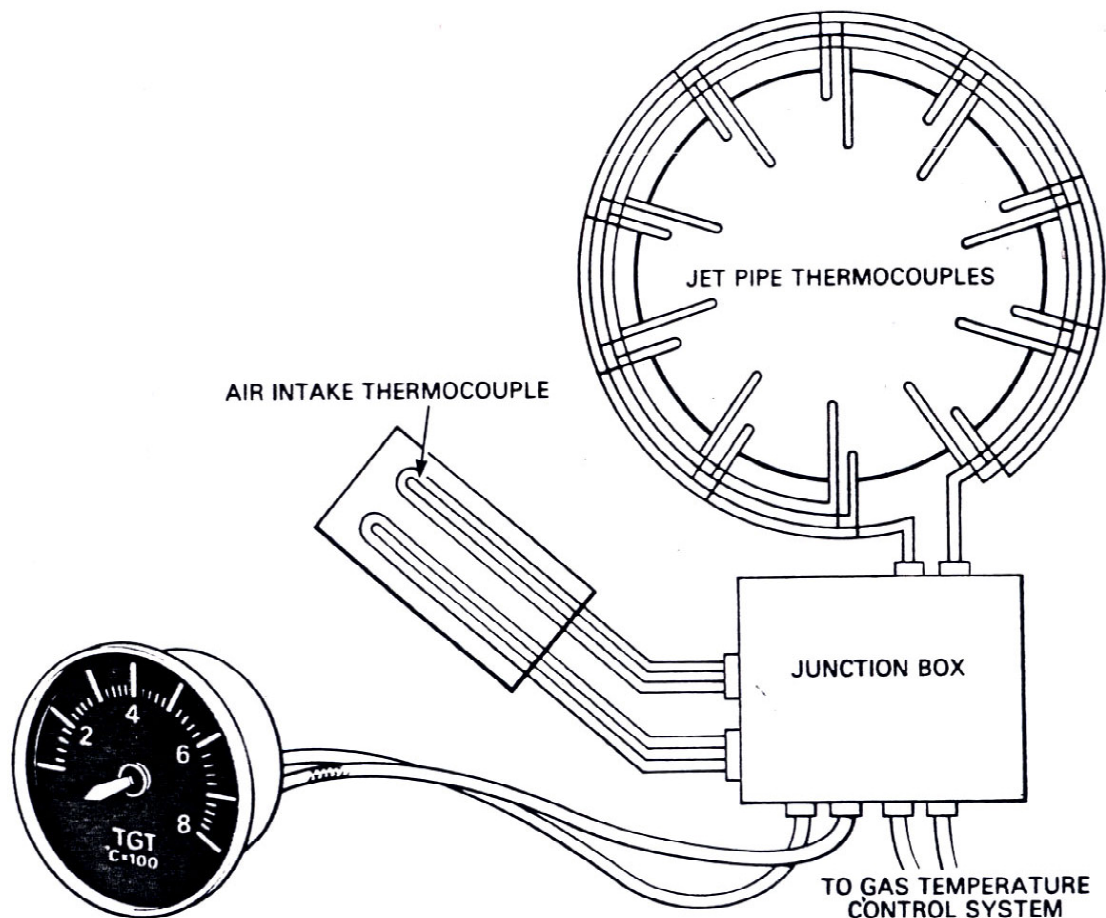

Fig. 11.2. A typical double element thermocouple system.

### E.G.T. Indicator

The temperature of the exhaust section of any turbine engine must be monitored to prevent overheating of the turbine blades and other exhaust components. There are many terms used to describe the temperature of the exhaust section. Most often the terms used will be determined by the location of the temperature probes in the exhaust stream. Some of the terms used are turbine-gas temperature (TGT), exhaust-gas temperature (EGT), inter stage turbine temperature (ITT), turbine outlet temperature (TOT), and turbine inlet temperature (TIT). The exhaust is measured in degrees centigrade and will generally range from 350 to 500°C [662 to 932°F].

The turbine inlet temperature (TIT) is the most critical of all the engine variables. However, it is impractical to measure TIT in some engines, especially large models. In these engines, thermocouples are inserted at the point of turbine discharge (exhaust gas). This EGT temperature reading provides a relative indication of the temperature at the turbine inlet. In other engines, the temperature-sensing probes (thermocouples) are placed at various positions in the turbine section, as previously described. Several thermocouples are usually used, spaced at intervals around the perimeter of the engine exhaust duct near the turbine exit. The EGT indicator, shown in Fig. 11.3, displays the average temperature measured by the individual thermocouples.

An example of a system that measures the exhaust gases at a different location is the Pratt and Whitney PT6A engine. In this system, the temperature is taken as inter stage turbine temperature (ITT). The ITT-sensing system, shown in Fig. 11.4, provides the pilot with an indication of the engine operating temperature occurring in the zone between the compressor turbine and the first-stage power-turbine stator vane ring. The system consists of a bus-bar-and-probe assembly, a wiring harness, an externally mounted terminal block, and

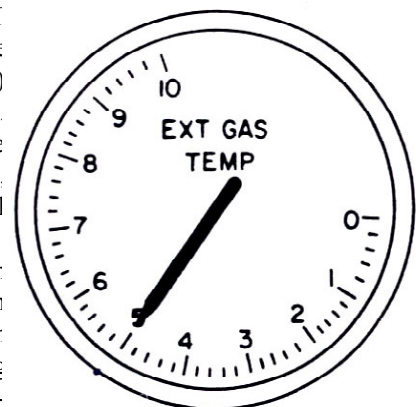

Fig. 11.3. EGT gage

a trim harness incorporating a thermocouple probe and preset variable resistor. The thermocouple is connected in parallel with the wiring harness to bias the ITT signal so that the indicated ITT bears a fixed relationship with the compressor inlet temperature.

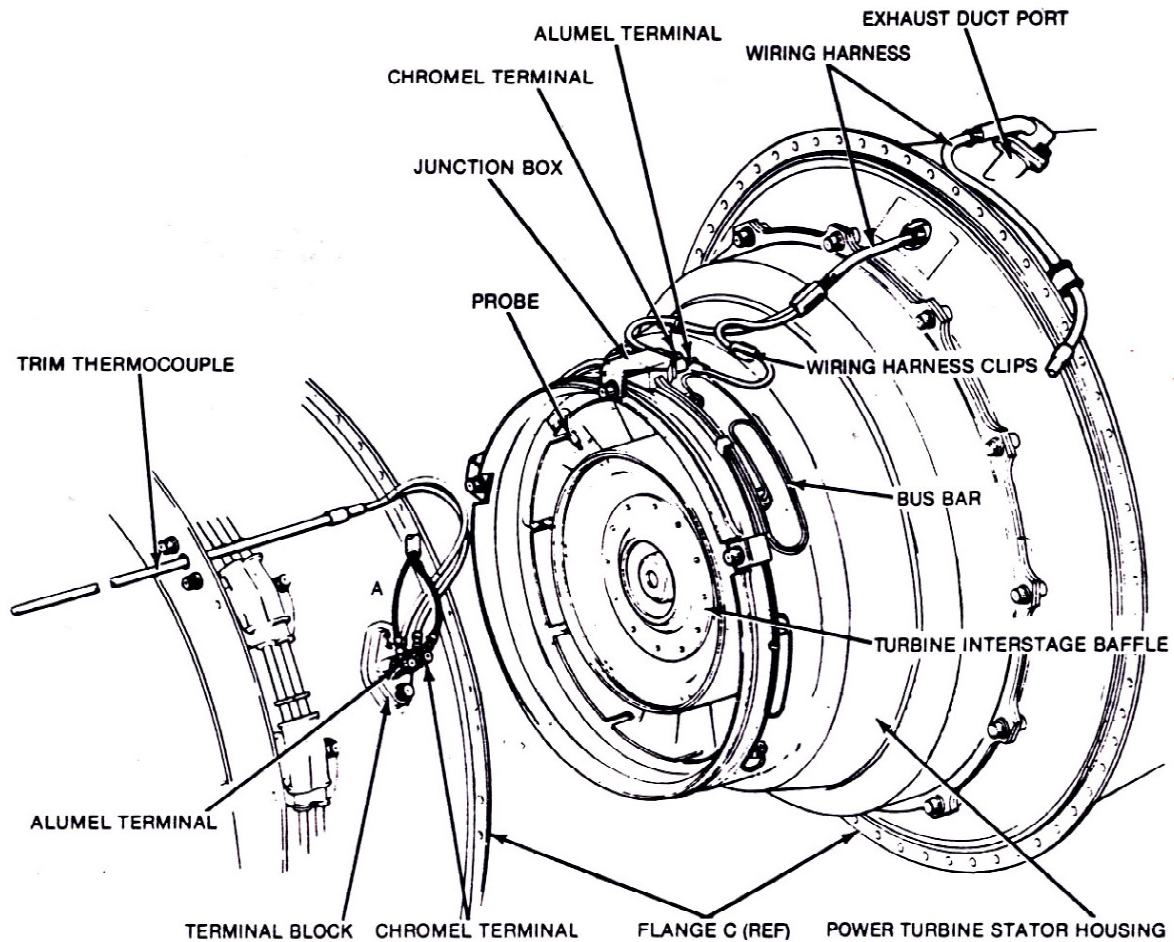

Fig. 11.4. ITT-sensing system

### Engine Speed Indication

All engines have their rotational speed (r.p.m.) indicated. On a twin or triple-spool engine, the high pressure assembly speed is always indicated; in most instances, additional indicators show the speed of the low pressure and intermediate pressure assemblies.

Engine speed indication is electrically transmitted from a small generator, driven by the engine, to an indicator that shows the actual revolutions per minute (r.p.m.) or a percentage of the maximum engine speed (fig. 11.5). The engine speed is often used to assess engine thrust, but it does not give an absolute indication of the thrust being produced because inlet temperature and pressure conditions affect the thrust at a given engine speed.

The engine speed generator supplies a three phase alternating current, the frequency of which is dependent upon engine speed. The generator output frequency controls the speed of a synchronous motor in the indicator, and rotation of a magnet assembly housed in a drum or drag cup induces movement of the drum and consequent movement of the indicator pointer.

Where there is no provision for driving a generator, a variable-reluctance speed probe, in conjunction with a phonic wheel, may be used to induce an electric current that is amplified and then transmitted to an indicator (fig. 11.6). This method can be used to provide an indication of r.p.m. without the need for a separately driven generator, with its associated drives, thus reducing the number of components and moving parts in the engine.

The speed probe is positioned on the compressor casing in line with the phonic wheel, which is a machined part of the compressor shaft. The teeth on the periphery of the wheel pass the probe once each revolution and induce an electric current by varying the magnetic flux across a coil in the probe. The magnitude of the current is governed by the rate of change of the magnetic flux and is thus directly related to engine speed.

In addition to providing an indication of rotor speed, the current induced at the speed probe can be used to illuminate a warning lamp on the instrument panel to indicate to the pilot that a rotor assembly is turning. This is particularly important at engine start, because it informs the pilot when to open the fuel cock to allow fuel to the engine. The lamp is connected into the starting circuit and is only illuminated during the starting cycle.

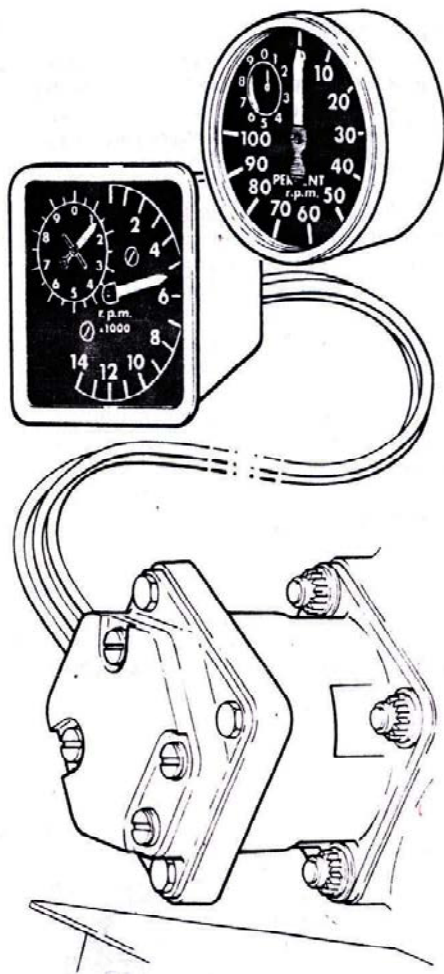

Fig. 11.5. Engine speed indicators and generator.

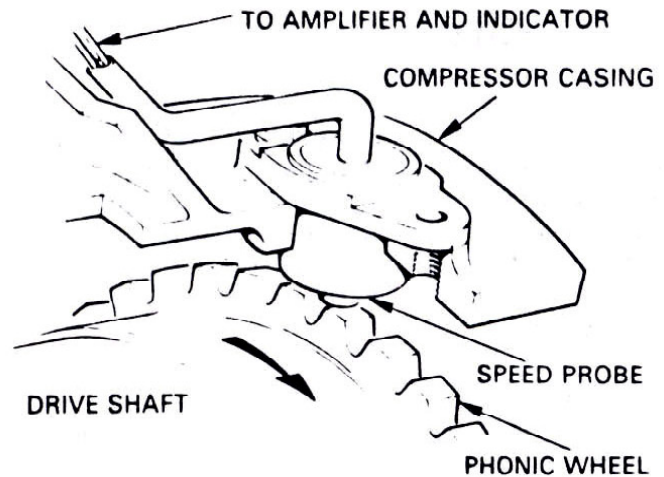

Fig. 11.6. Variable-reluctance speed probe and phonic wheel.

### Engine Thrust Indication/ Engine Pressure Ratio

The thrust of an engine is shown on a thrust meter, which will be one of two basic types, the first measures turbine discharge or jet pipe pressure, and the second, known as an engine pressure ratio (E.P.R.) gauge, measures the ratio, at two or three parameter when EPR is measured the ratio is usually that of jet pipe pressure to compressor inlet pressure. However, on a fan engine the ratio may be that of integrated turbine discharge and fan outlet pressures to compressor inlet pressure.

In each instance, an indication of thrust output is given, although when only the turbine discharge pressure is measured, correction is necessary for variation of inlet pressure; however, both types may require correction for variation of ambient air temperature. To compensate for ambient atmospheric conditions, it is possible to set a correction figure to a sub-scale on the gauge; thus, the minimum thrust output can be checked under all operating conditions.

Suitably positioned pitot tubes sense the pressure appropriate to the type of indication being taken from the engine. The pitot tubes are either directly connected to the indicator or to a pressure transmitter that is electrically connected to the indicator.

An indicator that shows only the turbine discharge pressure is basically a gauge, the dial of which may be marked in pounds per square inch (p.s.i.), inches of mercury (in. Hg.), or a percentage of the maximum thrust.

E.P.R. can be indicated by either electromechanical or electronic transmitters. In both cases the inputs to the transmitter are engine inlet pressure ( $P_1$ ) and an integrated pressure ( $P_{INT}$ ) comprised of fan outlet and turbine exhaust pressures. In some cases either fan outlet pressure or turbine exhaust pressure are used alone in place of  $P_{INT}$ .

The electro-mechanical system indicates a change in pressure by using transducer capsules (fig. 11.7) to deflect the centre shaft of the pressure transducer causing the yoke to pivot about the axis A.A. This movement is sensed by the linear variable differential transformer (L.V.D.T.) and converted to an a.c. electrical signal which is amplified and applied to the control winding of the servo motor.

The servo motor, through the gears, alters the potentiometer output voltage signal to the E.P.R. indicator and simultaneously drives the gimbal in the same direction as the initial yoke movement until the L.V.D.T. signal to the motor is cancelled and the system stabilizes at the new setting.

The electronic E.P.R. system utilizes two vibrating cylinder pressure transducers which sense the engine air pressures and vibrate at frequencies relative to these pressures. From these vibration frequencies electrical signals of E.P.R. are computed and are supplied to the E.P.R. gauge and electronic engine control system.

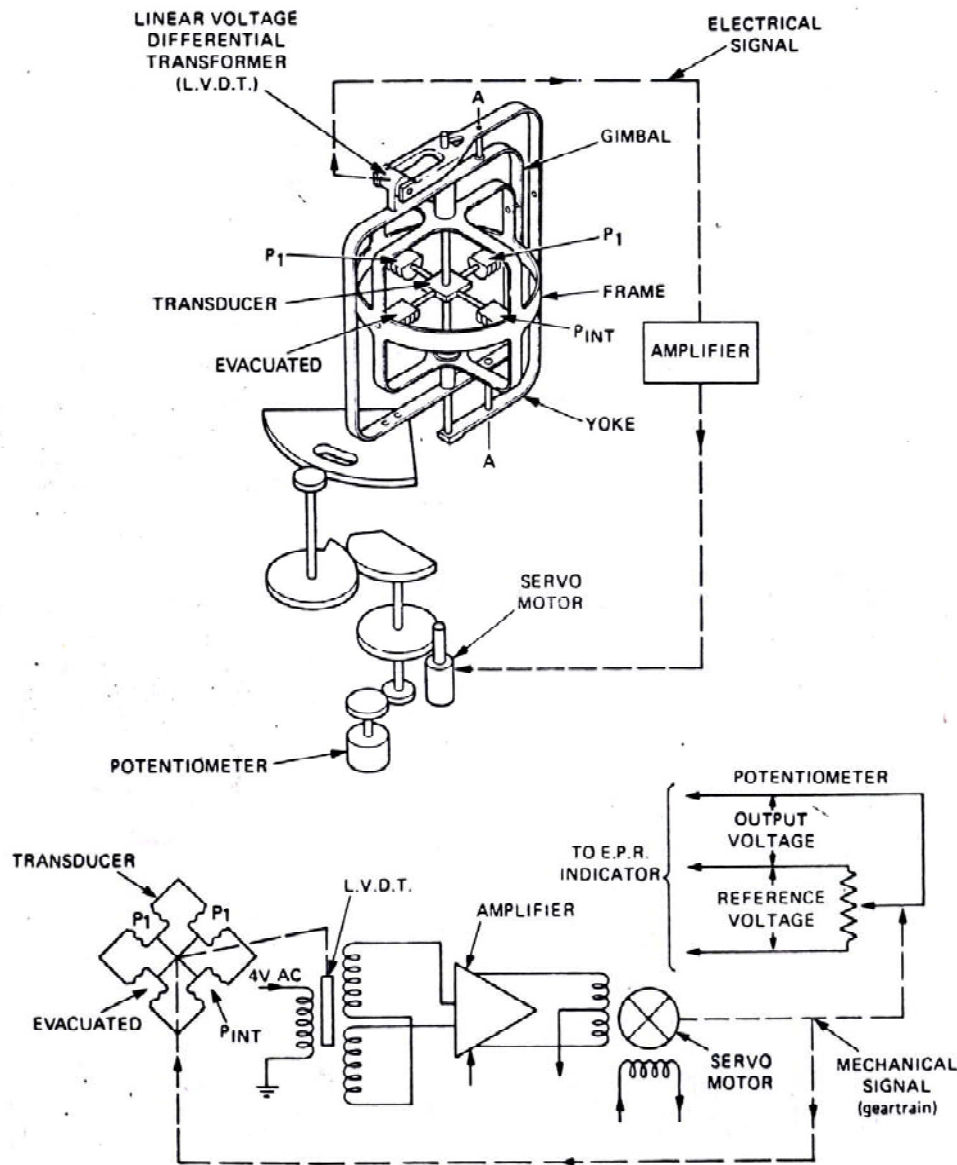

Fig. 11.7. Electro-mechanical E.P.R. transmitter.

## ENGINE TURBINE DISCHARGE PRESSURE OR JET PIPE PRESSURE SYSTEM

### General

- The engine pressure ratio (EPR) indicating system shows the engine power output to guide the pilots in selecting the optimum engine thrust setting for takeoffs and flight conditions. The EPR indicating system consists of one inlet pressure ( $P_{t2}$ ) sensing probe, six exhaust pressure ( $P_{t7}$ ) sensing probes, a pressure ratio transmitter and a pressure ratio indicator for each engine. (see figure 11.8)
- The engine inlet and exhaust pressures, sensed by the pressure sensing probes, are transmitted through tubing to the pressure ratio transmitter. The transmitter converts the exhaust and inlet pressures into a ratio. A synchro transmitter, an integral part of the EPR transmitter, generates three-phase electrical signals whenever the pressure ratio changes. These signals are transmitted to the respective engine pressure ratio indicator. The indicator transforms the electrical input signals into the indicator pointer shaft rotation to show the engine pressure ratio.

### Inlet Pressure Sensing Probe

The engine inlet pressure ( $P_{t2}$ ) is sensed by a probe similar to a Pitot tube. This probe is mounted through the center of the nose dome with open end of the tube facing the inlet air stream. The vent hole in this probe functions as the probe ice detector by decreasing engine inlet pressure (increasing EPR) when icing occurs. The probe is anti-iced by the engine anti-ice system.

### Exhaust Pressure Sensing Probe

The engine has six exhaust (discharge, Pt7) pressure sensing probes projected into the stream of turbine exhaust gases. The probes are connected to a common manifold for obtaining an average pressure of the exhaust gases. Exterior connection to the manifold is made at a single point through the fan discharge outer duct at approximately the seven O'clock position. (see figure 11.8)

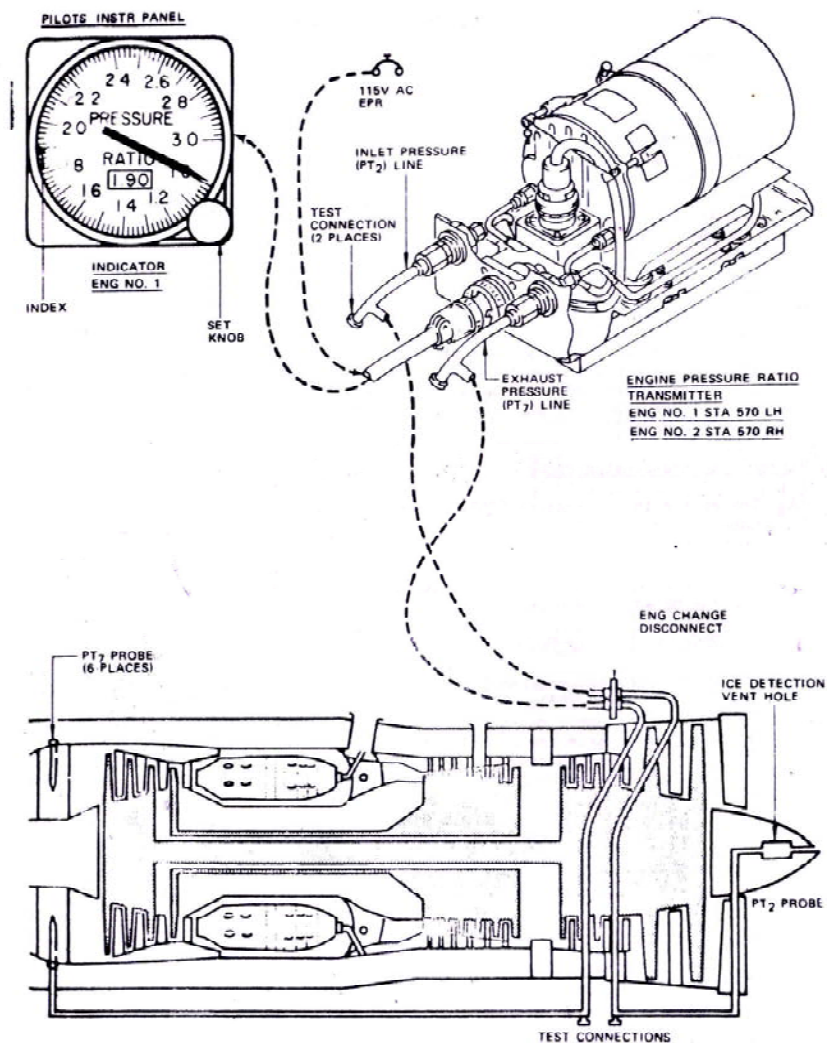

Fig. 11.8. Pressure Ratio Indicating System.

### Engine Pressure Ratio Transmeter

- A. The engine pressure ratio transmiter converts the exhaust, pressure (Pt7) and the inlet pressure (Pt2) into a ratio, and generates three-phase electrical signals corresponding to pressure changes in the engine. It consists of two bellows (multicell diaphragms), a sensing mechanism, an amplifier, a motor-gear train, and a synchro transmitter. The engine pressure ratio transmitters are located on the right and left side of the airplane in the air conditioning bay.
- B. The engine exhaust and inlet pressures are applied to the bellows assembly of the transmiter. A change in either of these pressures cause differential bellows movement. The bellows movement affects the sensing mechanism which, with the aid of the amplifier and the motor gear train, causes the ( synchro transmitter) rotor to rotate and generate three-phase electrical signals.

### Engine Pressure Ratio Indicator

- A. The engine pressure ratio indicator provides a visual indication of the engine exhaust and inlet pressure (Pt7/Pt2). It consists of a synchro receiver and a graduated dial face. There is one indicator for each engine. The indicators are located on the instrument panel.
- B. The engine pressure ratio indicator transforms electrical three-phase input signals into indicator pointer shaft rotation, to show performance of the engine.

### Operation

- A. The System operates on ac power. (see figure 11.9).
- B. The engine exhaust and inlet pressures are sensed by the pressure sensing probes. These pressure act on the bellows assembly of the pressure ratio transmitter, causing differential bellows movement whenever either of the pressures change. The relative bellows movement effects the sensing mechanism of the EPR transmitter which, with the aid of the amplifier and motor-gear train, cause the sychro transmitter rotor to amplify and motor-gear train, cause the sychro transmitter rotor to rotate and generate three-phase electrical signals. The generated electrical signals are transmitted to a respective pressure ratio indicator over a three-wire system. The indicator converts the electrical signals into the pointer shaft rotation or indicator pointer movement corresponding to the pressure change in the engine.

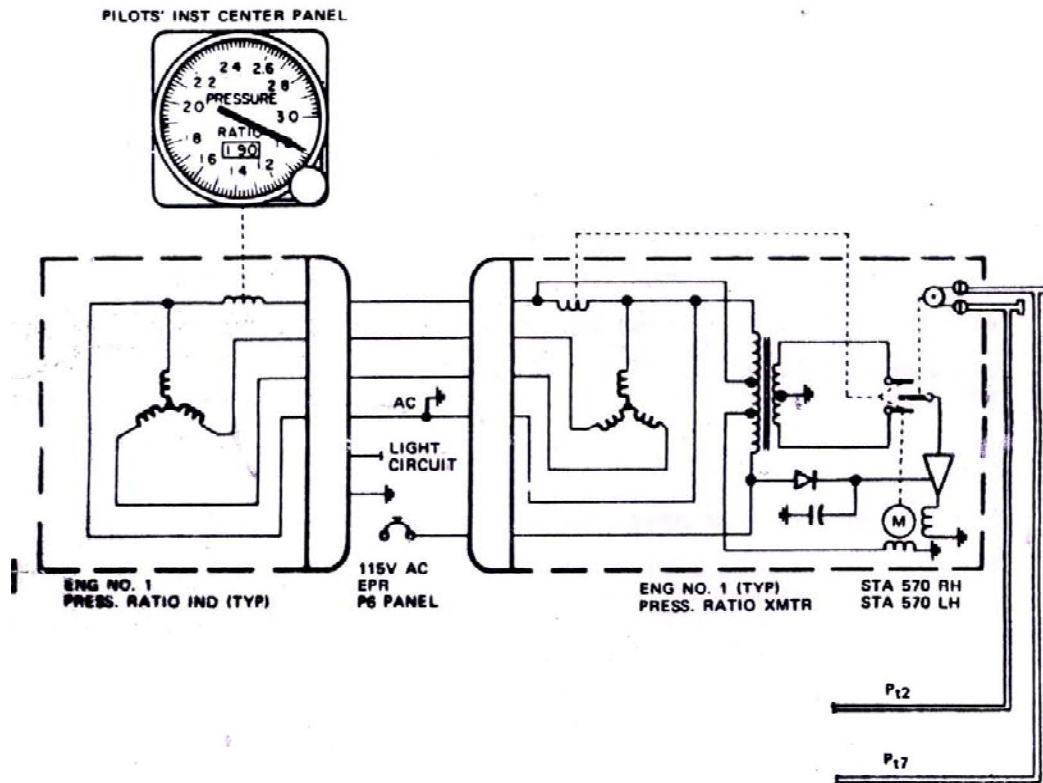

Fig. 11.9. Engine Pressure Ratio Indicating System Schematic.

### Oil temperature and pressure

It is essential for correct and safe operation of the engine that accurate indication is obtained of both the temperature and pressure of the oil. Temperature and pressure transmitters and indicators are illustrated in fig. 11.10

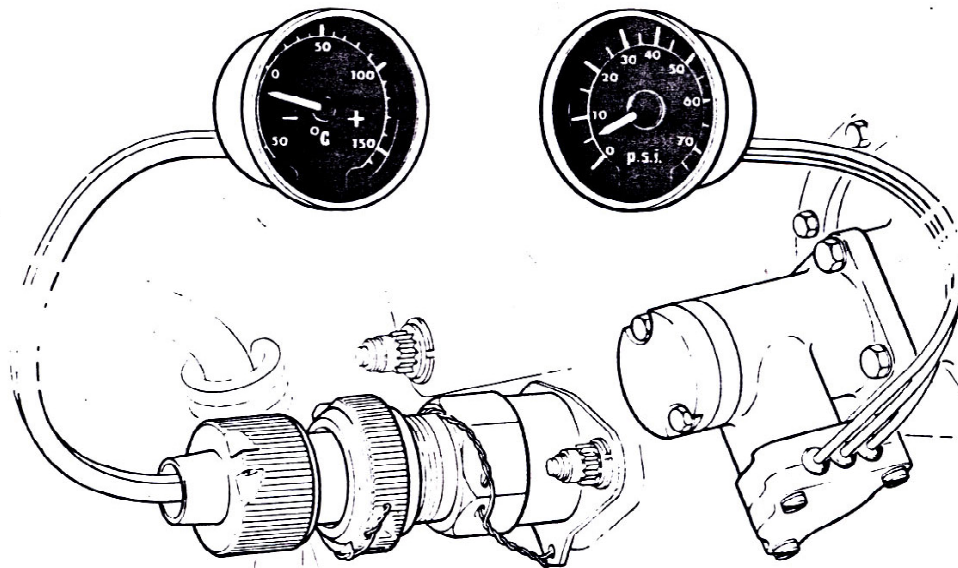

Fig. 11.10. Oil Temperature and pressure transmitters and indicators.

Oil temperature is sensed by a temperature sensitive element fitted in the oil system. A change in temperature causes a change in the resistance value and, consequently, a corresponding change in the current flow at the indicator. The indicator pointer is deflected by an amount equivalent to the temperature change and this is recorded on the gauge in degrees centigrade.

Oil pressure is electrically transmitted to an indicator on the instrument panel. Some installations use a flag-type indicator, which indicates if the pressure is high, normal or low; others use a dial type gauge calibrated in pounds per square inch (p.s.i.).

Electrical operation of each type is similar; oil pressure, acting on the transmitter, causes a change in the electric current supplied to the indicator. The amount of change is proportional to the pressure applied at the transmitter.

The transmitter may be of either the direct or the differential pressure type. The latter senses the pressure difference between engine feed and return oil pressure, the return oil being pressurized by cooling and sealing air from the bearings.

In addition to a pressure gauge operated by a transmitter, an oil low pressure warning switch may be provided to indicate that a minimum pressure is available for continued safe running of the engine. The switch is connected to a warning lamp in the flight compartment and the lamp illuminates if the pressure falls below an acceptable minimum.

The temperature-sensing bulb is usually located in the engine oil system at a point immediately after the oil has passed through the oil cooler. Some oil cooler have provision for the temperature bulb to be installed near the outlet of the cooler. In any event, the temperature gage measures the temperature of the oil entering the engine. The face of the oil temperature gage is marked with a green band showing the range of normal operating temperatures. Red lines are used for both the minimum allowable operating temperature and the maximum safe temperature. The manufacturer usually specifies the temperature limits for engine operation. As a general rule, 40°C (104°F) is considered the minimum safe temperature for operation, 60 to 70°C (140 to 158°F) is the normal operating range, and 100°C (212°F) is the maximum allowable temperature for a reciprocating engine.





## CHAPTER - 12

### ENGINE INDICATING SYSTEM (PART-II)

#### FUEL TEMPERATURE AND PRESSURE

The temperature and pressure of the low pressure fuel supply are electrically transmitted to their respective indicators and these show if the low pressure system is providing an adequate supply of fuel without cavitation and at a temperature to suit the operating conditions. The fuel temperature and pressure indicators are similar to those for oil temperature and pressure indication.

On some engines, a fuel differential pressure switch, fitted to the low pressure fuel filter, senses the pressure difference across the filter element. The switch is connected to a warning lamp that provides indication of partial filter blockage, with the possibility of fuel starvation.

#### Fuel Pressure gage

Several different types of fuel pressure gages are in use for aircraft engines, each designed to meet the requirements of the particular engine fuel system with which it is associated. The technician should identify the type of gage under consideration before making judgments regarding its operation or indications.

Any fuel system utilizing an engine-driven or electric fuel pump must have a fuel pressure gage to ensure that the system is working properly. If a float-type carburetor is used with the engine, the fuel pressure gage will be a basic type, probably with a green range marking from 3 to 6 psi [20.69 to 41.37 kPa]. If the engine is equipped with a pressure discharge carburetor, the range marking on the fuel pressure gage will be placed in keeping with the fuel pressure specified for the carburetor. This will probably be between 15 and 20 psi [103.43 and 137.9 kPa]. A red limit line will be placed at each end of the pressure-range band to indicate that the engine must not be operated outside the specified range.

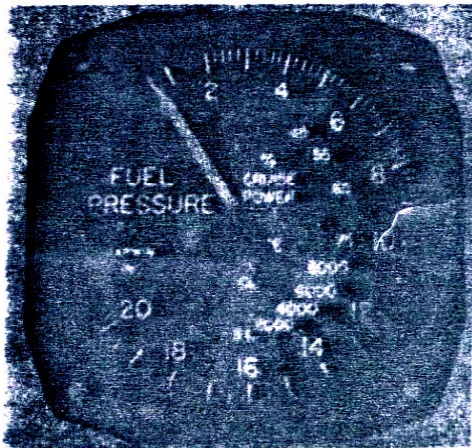

Fig. 12.1. A Fuel Pressure gage.

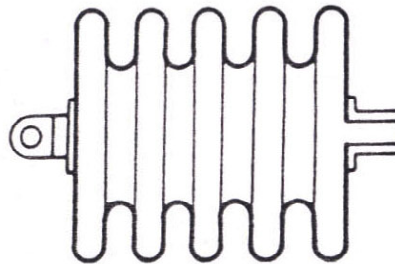

Fig. 12.2. A bellows capsule.

If an engine is equipped with either a direct fuel injection system or a continuous-flow fuel injection system, the fuel pressure is a direct indication of power output. Since engine power is proportional to fuel consumption and since fuel flow through the nozzles is directly proportional to pressure, fuel pressure can be translated into engine power or fuel flow rate, or both. The fuel pressure gage, therefore, can be calibrated in terms of percentage of power. A gage of this type is shown in Fig. 12.1. Note that the instrument indicates a wide range of pressures at which the engine can operate. It is calibrated in pounds per square inch and also indicates percentage-of-power and altitude limitations. The face of the instrument is color-coded blue to show the normal cruise range during which the engine can be operated in AUTO LEAN and green to show the range during which the AUTO RICH mixture setting should be used.

Fuel pressure gages are similar in construction to other pressure gages used for relatively low pressures. The actuating mechanism is either a diaphragm or a pair of bellows. The advantage of the bellows is that it provides a greater range of movement than does a diaphragm. In a typical fuel gage, the mechanism includes two bellows capsules joined end to end. A bellows capsule is shown in Fig. 12.2. One capsule is connected to the fuel pressure line and the other is vented to ambient pressure in the airplane. The fuel pressure causes the fuel bellows to expand and move toward the air capsule. This movement is transmitted to the indicating needle by means of conventional linkage.

#### Fuel Flow Meters

Although the amount of fuel consumed during a given flight may vary slightly between engines of the same type, fuel flow does provide a useful indication of the satisfactory operation of the engine and of the amount of fuel being consumed during the flight. A typical system consists of a fuel flow transmitter, which is fitted into the low pressure

fuel system, and an indicator, which shows the rate of fuel flow and the total used in gallons, pounds or kilogrammes per hour (fig. 12.3). The transmitter measures the fuel flow electrically and an associated electronic unit gives a signal to the indicator proportional to the fuel flow.

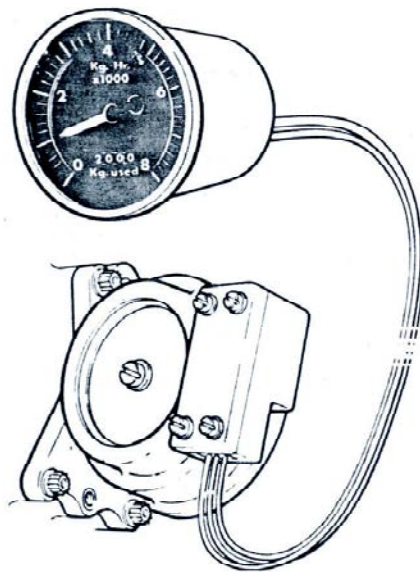

Fig. 12.3 Fuel flow transmitter and Indicator.

Fuel flowmeters are employed on all large aircraft to provide the flight engineer or pilot with important information regarding the efficient operation of the engines. The flowmeter is the most accurate way to determine fuel consumption for all types of engines. The quantity of fuel being burned per hour, when integrated with other factors, makes it possible to adjust power settings for maximum range, maximum speed, or maximum economy of operation. If the fuel consumption of an engine is abnormal for any particular power setting, the operator is warned by the fuel flowmeter that there is something wrong (a fault) in the engine or its associated systems.

Fuel flowmeters may be scaled for pounds per hour, gallons per hour, or kilograms per hour. The most accurate units of measurement for fuel are the pound and the kilogram, because these are measures of weight. Since the weight of a gallon of fuel varies with temperature, fuel temperature would have to be considered in making a computation based on gallons per hour of fuel consumption.

In engine test cells, a tubular flowmeter is often used. This is simply a glass or plastic tube with a tapered inside diameter. The tube is mounted vertically with an indicating ball inside. Fuel enters the bottom of the tube and flows out the top and in so doing causes the indicating ball to rise a distance proportional to the rate of fuel flow. Figure 4.4 shows a tubular fuel flowmeter.

Light aircraft with continuous-flow fuel injection engines usually employ a fuel pressure gage which also serves as a flowmeter. This is possible because the fuel flow in a direct fuel injection system is proportional to fuel pressure. The instrument can therefore be calibrated either in pounds per square inch or gallons per hour, or both. A gage of this type is shown in Fig. 12.4. Owing to its design characteristics, this system is not as accurate as the above-mentioned fuel flowmeters. If a fuel injection nozzle were to become clogged, the gage would indicate high fuel flow rather than the lower indication normally expected.

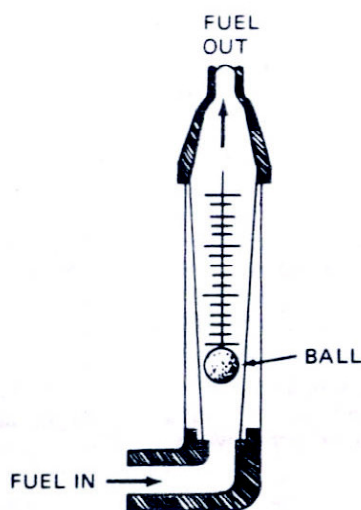

Fig.12.3. Tubular fuel flowmeter.

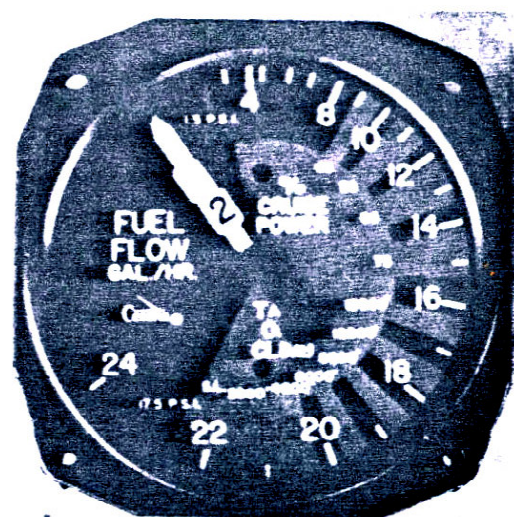

Fig. 12.4. Fuel pressure gage also used as a flowmeter.

Fuel flow indicating systems for large aircraft are of two general types. The first, used in many older aircraft, employs a synchro system to transmit a measurement of fuel flow from the sensor and transmitter to the indicator. The principle of the synchro system is illustrated in Fig. 12.5. Fuel flow through the flow sensor causes rotation of the transmitter rotor to a position proportional to the fuel flow rate. The rotor, being energized electrically by 400 Hz ac, generates a three-phase current in the stator which flows through the stator of the indicator. The magnetic field thus produced reacts with the field of the rotor in the indicator and causes it to assume a position corresponding to the position of the rotor in the transmitter. The indicator needle is mounted on the shaft with the rotor; therefore, it moves to a position established by the rotor. The indicator needle thereby shows the fuel flow rate on the instrument scale.

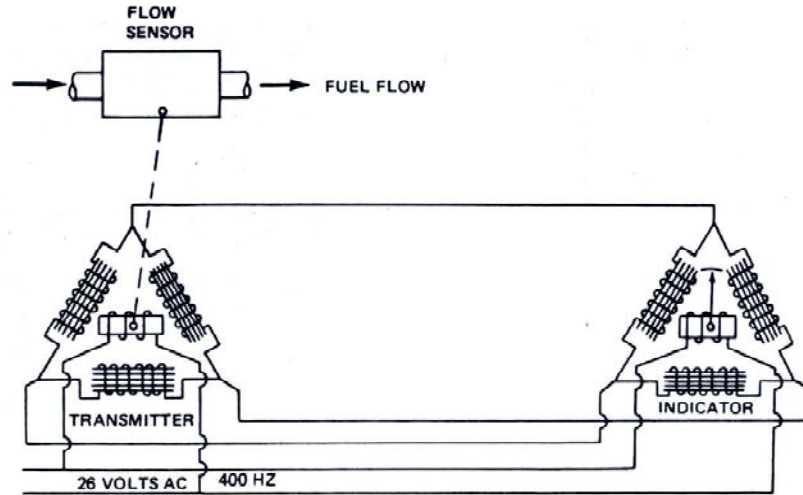

Fig. 12.5. Flowmeter utilizing a synchro transmitting system.

Fuel flow indicating systems for modern jet aircraft are complex electrical and electronic circuits and devices. The transmitter is located in the fuel line between the engine driven fuel pump and the carburetor, or fuel control unit. The sensing device may be a gate-type unit, or it may be a turbine which generates an electrical signal. In any case, the signal sent from the transmitter contains the required information regarding fuel flow rate. The electrical signal is delivered to the “receiver” of the indicator, where it is converted to a form which provides movement of the indicator needle.

**INTEGRATED FLOWMETERS SYSTEM**

An integrated flowmeter system may broadly be defined as one in which a fuel consumed measuring element is combined with that of fuel flow, thus permitting the display of both quantities in a single indicator.

In order to accomplish this it is necessary to introduce an integrating system to work out fuel consumed in the ratio of fuel flow rate to time. Such a system may be mechanical, forming an integral part of an indicator mechanism, or as in electronic fuel flow measuring systems, it may be a special dividing stage within the amplifier, or even a completely separate integrator unit.

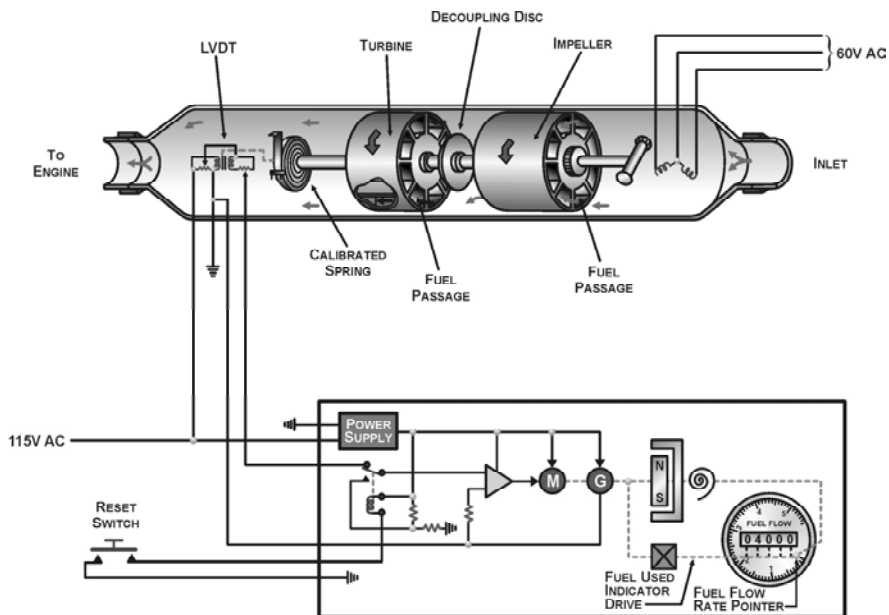

Fig. 12.6. Integrated Flowmeter System.

The components of a typical system are shown in fig. 12.6. The transmitter comprises an impeller driven by a two-phase ac motor, a turbine which is interconnected with a calibrated restraining spring, and an LVDT sensor. A decoupling disc is located between the impeller and turbine, its purpose being to prevent an 'hydraulic transmission' effect on both units when operating at low rates of fuel flow. The indicator is servo-operated with the drive to the flow rate pointer being effected by means of an eddy-current drag type of mechanism similar to that adopted in some rpm indicators. The fuel consumed indicator is a digital counter which is mechanically integrated with the servomotor via a gear transmission, the ratio of which is preselected to establish the requisite relationship between the motor speed, which is proportional to flow rate, and time.

The system is supplied with 115V single-phase 400 Hz ac from an aircraft's power system and this utilized by a power supply unit within the indicator, the primary coil of the LVDT in the transmitter, and by a separate power supply unit (not shown in the diagram). This unit contains a temperature stable oscillator connected to a voltage/frequency converter which converts the main supply into a two-phase 60V 8 Hz output; this, in supplied to the transmitter impeller motor. The rotating field set up in the rotor windings interjects with its permanent magnet rotor which rotates in synchronism and drives the impeller at a constant speed.

Fuel flow rate is, in the first instance, always established by an engine's fuel control unit which is calibrated or 'trimmed' to control rates commensurate with the varying operational conditions and the other associated power parameters, i.e. rpm, EGT and EPR. When fuel enters the transmitter it passes through passages in the impeller which, on account of its rotation, causes the fuel to swirl at a velocity governed by the flow rate. The fuel is then diverted around the decoupling disc, and in passing through passages in the turbine, it imparts a rotational force which tends to continuously rotate the turbine in the same direction as the impeller. This tendency is, however, restrained by the calibrated spring such that the rotation is limited and balanced at an angular position proportional to the flow rate of fuel passing through the transmitter.

The movement of the turbine and its shaft alters the position of the LVDT sensor core, so that a signal voltage (up to 5V at maximum flow rate) is induced in the secondary winding and supplied to the indicator servomotor via the closed contacts of the reset relay and amplifier. The servomotor rotates at a speed proportional to the flow rate, and by means of the eddy-current drag, mechanism positions the pointer to indicate this rate.

### MANIFOLD PRESSURE

The cockpit instruments that are mostly concerned with the control setting of the propeller are the tachometer and the MAP (manifold absolute pressure) gage. The tachometer indicates the rpm of the engine's crankshaft while the manifold pressure gage measures the absolute pressure in the intake manifold. If an aircraft is equipped with a constant-speed propeller, the aircraft will also have a MAP gage to assist with setting the correct amount of engine power during climb and cruise. The MAP gage and the tachometer are each marked with a green arc to indicate the normal operating range and a yellow arc for the takeoff and precautionary range. The tachometer is also sometimes precautionary range. The tachometer is also sometimes marked with a red arc for critical vibration range and a red radial line for maximum operating limit. A typical tachometer and MAP gage can be seen in Fig. 12.7.

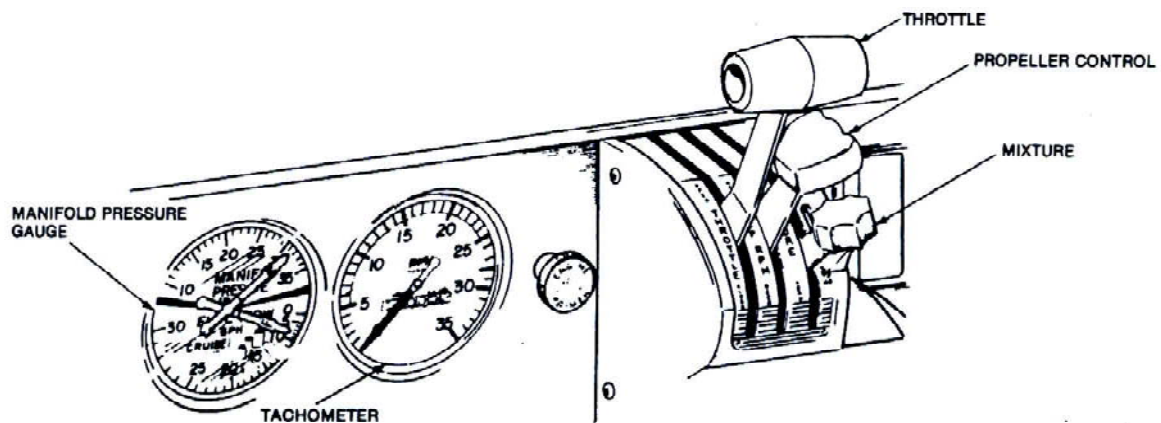

Fig. 12.7. Cockpit instruments and propeller control.

An engine instrument which utilizes a diaphragm to sense pressure is the manifold pressure (MAP) gage. The acronym MAP is used to indicate manifold pressure because manifold pressure is absolute pressure; thus, MAP stands for manifold absolute pressure. The manifold pressure gage (Map gage) is, in effect, a barometer, because it measures atmospheric pressure when it is not connected to a running engine. When the engine is stopped, the MAP gage should indicate the local barometric pressure. To accomplish this, the MAP gage is provided with two diaphragms. One diaphragm is a sealed aneroid cell which responds to ambient atmospheric pressure. The other diaphragm is connected to the intake manifold of the engine and responds to the MAP. The effect is that the gage provides an indication of the absolute pressure (pressure above zero pressure) existing in the intake manifold of the engine.

MAP gages may be designed so that the MAP of the engine is applied to the inside of a diaphragm or to the exterior of the diaphragm in a sealed instrument case. In all cases the instrument must be designed so that the chemical constituents in the intake manifold will not get into the operating mechanisms of the instrument. Furthermore, the

pressure line from the manifold to the diaphragm or instrument case must be provided with a restriction, such as a coiled capillary tube, to prevent excessive pressures from reaching the instrument, as in the case of a backfire.

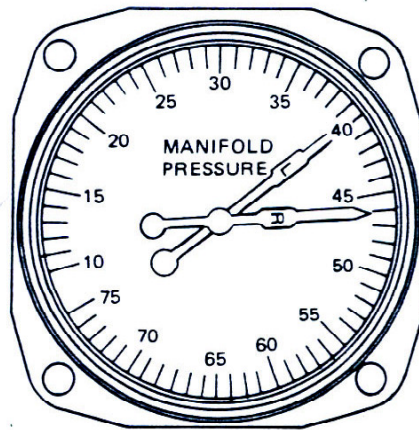
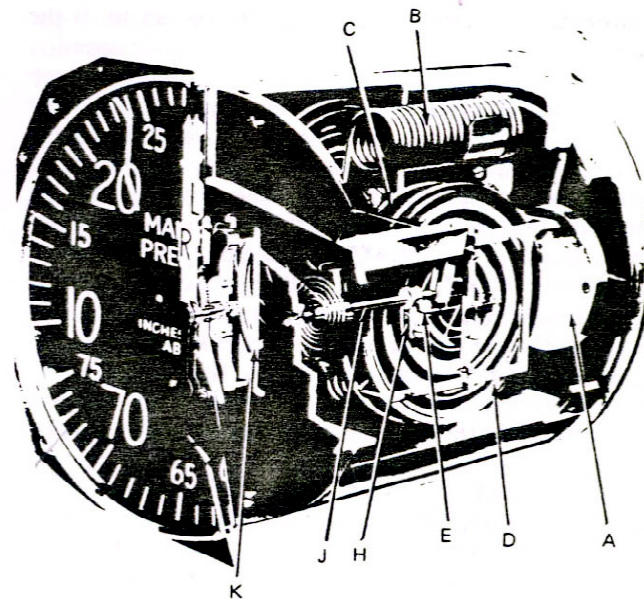

Fig. 12.8. The face of a MAP gage.

The face of a typical MAP gage is shown in Fig.12.7, and the interior mechanism is shown in Fig.12.8. The cover glass on the face or the dial of the instrument has limit and range markings to aid the pilot in operating the engine safely and efficiently. A range marked in blue shows the MAP values which may be used while operating in AUTO LEAN, and a green band shows the range of pressures which are satisfactory for AUTO RICH. A red line indicates maximum allowable MAP for takeoff power, and a white line shows slippage of the cover glass.



- |                        |                                       |
|------------------------|---------------------------------------|
| A. pressure connection | E. bimetallic temperature compensator |
| B. capillary coil      | H. actuating arm                      |
| C. pressure diaphragm  | J. rocking shaft                      |
| D. aneroid diaphragm   | K. sector gear                        |

Fig. 12.9. Interior mechanism of a MAP gage.

The MAP gage is particularly important for use with supercharged engines and those with which constant-speed propellers are employed, because the MAP has a direct effect on mean effective pressure (mep). Excessive mep can cause severe engine damage. When an engine is being operated under supercharged. When an engine is being operated under supercharged MAPs, the pilot must know that safe operating pressures are not being exceeded. As explained previously, excessive MAPs cause high cylinder pressures, which result in detonation, overheating, and preignition.

When a naturally aspirated (unsupercharged) engine is operated with a constant-speed propeller, the pilot cannot determine the power output of the engine without knowing the MAP, because the engine rpm will be constant even when the power varies greatly.

The MAP gage is calibrated in inches of mercury (inHg). When the instrument is in standard sea-level conditions and is not on an operating engine, the reading of the instrument should be 29.92 in Hg [101.31 kPa]. Unsupercharged

engines always operate below atmospheric pressure because the engine is drawing air into the cylinders and the friction of the air passages causes a reduction in air pressure. When such an engine is idling, the MAP is likely to be less than one-half atmospheric pressure.

The MAP gage is installed in the instrument panel adjacent to other engine instruments. Ideally, it should be next to the tachometer so that the pilot can quickly read rpm and MAP to determine engine power output. The panel on which the instruments are mounted is usually a shock-mounted subpanel which is attached to the main instrument panel. During inspections, all the shock mountings should be examined carefully for damage and signs of deterioration.

The pressure line leading from the engine to the MAP gage may consist of metal tubing, a pressure hose, or a combination of both.

In some installations a purge valve is connected to the pressure line near the instrument. The purpose of this valve is to remove moisture from the line. To purge the line, the engine is started and operated at idle speed. Since the MAP at idling is less than 15 in Hg [50.79 kPa], a strong suction exists in the line. When the purge valve is opened, air flows through the valve and the pressure line to the engine. The Valve is held open for about 30s, and this effectively removes all moisture in the line. After the purge valve is closed, the MAP gage should show correct MAP for the engine.

During inspections, the MAP gage should be checked for proper operation. Before the engine is started, the gage should show local barometric pressure. After the engine has been started and is idling, the MAP gage reading should drop sharply. When the engine rpm is increased, the gage should be watched to see that it increases evenly and in proportion to power output. In the event that the reading lags or fails to register, the cause can usually be traced to one of the following discrepancies: (1) the restriction in the instrument case fitting is too small, (2) the tube leading from the engine to the gage is clogged or leaks, (3) the diameter of the tubing is too small for its length. If the reading is jumpy and erratic when the engine speed is increased, the restriction in the case fitting is probably too large. If there is a leak in the gage pressure line, the MAP will read high for an unsupercharged engine. If the pressure line is broken or disconnected, the MAP gage will read local barometric pressure. A leaking or broken pressure line on an unsupercharged engine will permit outside air to leak into the manifold and lean the mixture to some extent, depending on the size of the tubing and fitting. On a supercharged engine, a leaking or broken pressure line will allow air or a fuel-air mixture to escape, provided that the engine is operating at a MAP above atmospheric pressure.

Inspection and installation of the MAP gage should be similar to those of any other panel-mounted instrument.

**Turbopropeller Engine Torquemeters**

Engine torque is used to indicate the power that is developed by a turbopropeller engine. The torque display indicator is known as a torquemeter. The engine torque or turning moment is proportional to the horsepower and is transmitted through the propeller reduction gears. The engine operating condition, during which the torque indicating system is the most important, is called a “positive torque condition.” Positive torque occurs when the engine is producing the power that drives the propeller. The torque indicating system is designed to measure the torque that is produced by the engine at a point between the engine and the propeller. If the propeller was driving the engine, such as during an engine out condition, then negative torque would be produced.

The actual horsepower at a given torque indication must be related to the effect of rpm. The formula illustrated in Fig. 12.9. indicates that horsepower is a function of a mathematical constant (K) multiplied by the rpm and then by torque in foot-pounds. The K factor is a constant factor that does not change ( $K=2\pi/33,000$ ). If the formula is used to determine horsepower, the effect of rpm on the torque being produced at a given horsepower can be seen in Fig. 12.9. This example assumes that 900 horsepower is desired as a limit at both 100 percent and 96 percent engine speeds. The value of K (0.0001904) times 1591 propeller rpm (100 percent) times 2971 ft. lb (torque) equals 900 horsepower. Under this condition of 900 horsepower at a reduced rpm-representing minimum cruise of 96 percent - the propeller rpm would be 1527, and so the formula would yield a torque value of 3095 ft. lb. If the airframe manufacturer were to allow the pilot to maintain the same 900 horsepower at 96 percent rpm, there might be a second red line at the 3095 ft. lb [4 197 N . m] torque limit. Thus, with decreased rpm, the torque must increase to maintain the same horsepower; this example illustrates that torque is inversely proportional to rpm.

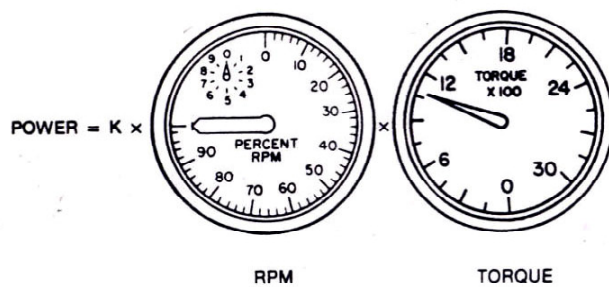

Fig. 12.10.  $K \times \text{rpm} \times \text{torque} = \text{horsepower}$

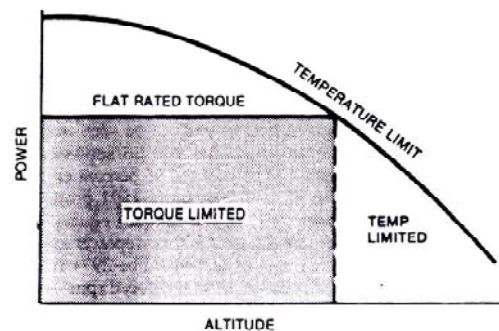

Fig.12.11. Torque limit operation

Exceeding the engine’s temperature or torque limitations may damage the aircraft or the engine. The curve in Fig. 12.11 indicates the torque/temperature relationship in the operation of an engine in a typical installation. It can be seen that at a certain point the temperature limit will take precedence over the torque limit as the aircraft reaches less dense air.

That point in pressure altitude or outside air temperature is a matter of the individual torque limit ratings applied by the airframe manufacturer. Consequently, the pilot must monitor the applicable engine instruments and observe the flight manual limits.

A torquemeter system is shown in Fig.4.12. In this hydromechanical system, the axial thrust produced moves the helical gear, which meters oil pressure acting on a piston. The position of the metering valve is controlled by the torquemeter piston, which reacts in direct proportion to engine torque. This pressure is transmitted to the transducer, which converts oil pressure into an electrical signal. The signal is passed on to the indicator in the cockpit, which is generally calibrated in foot-pounds of torque.

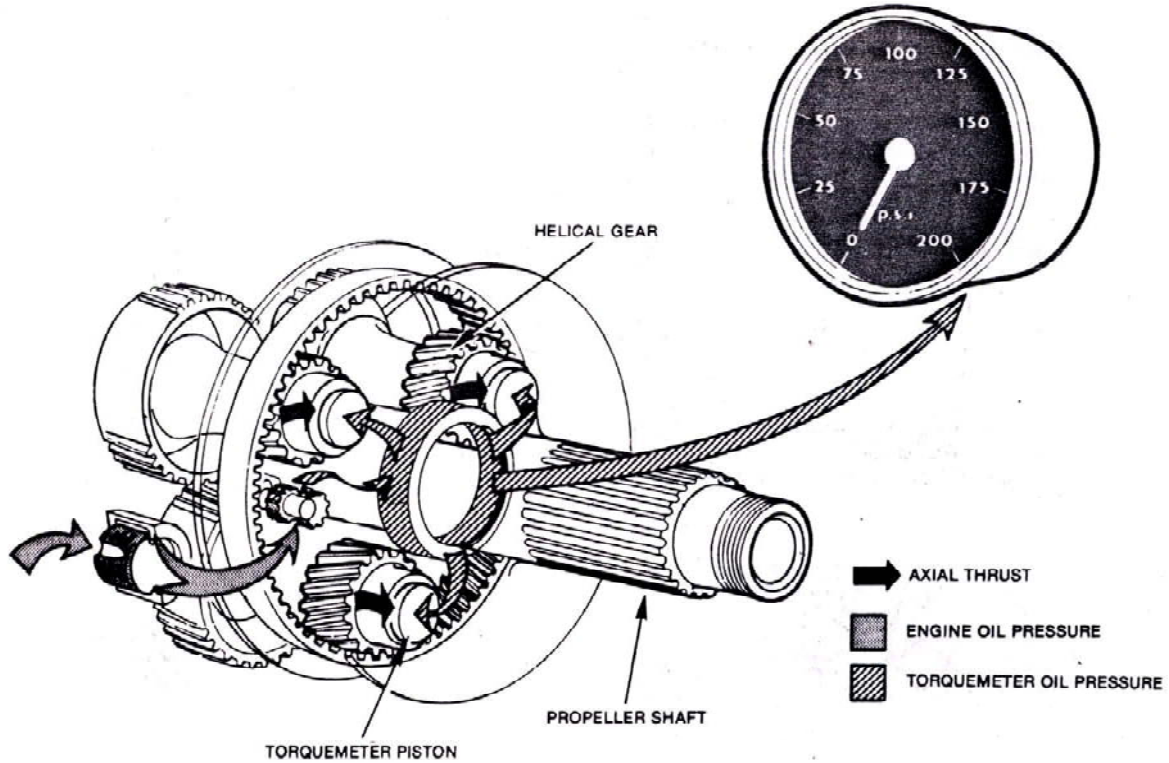

Fig. 12.12. A simple torquemeter system,

Another torque-indicating system which is basically an electronic system is used on the Garrett TPE331 engine. The major components of this system, illustrated in Fig.12.13, include a torque ring containing strain gages (sometimes referred to as the torque transducer) and an externally mounted signal conditioner, which sends a corrected signal to the cockpit torquemeter. Wiring from the electrical connector mounted on the diaphragm carries an electric signal externally from the gearbox to the signal conditioner. The signal conditioner is usually mounted somewhere in the nacelle adjacent to the engine. Electric signals from the conditioner are sent to the torquemeter in the cockpit.

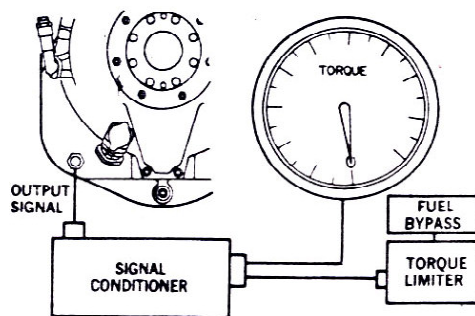

Fig. 12.13. Torque indication system.

In addition to providing an indication of engine power, the torquemeter system may also be used to operate a torque limiter system, if one is installed, and to signal the automatic propeller feathering system if the torquemeter oil pressure falls as a result of an engine power failure.

**Propeller Speed**

The propeller governor performs two functions. Under normal flight conditions it acts as a constant-speed governing unit to regulate power-turbine speed (N<sub>p</sub>) by varying the propeller blade pitch to match the load torque to the engine

torque in response to changing flight conditions. During low-air-speed operations, the propeller governor can be used to select the required blade angle (beta control). While in the beta control range, engine power is adjusted by the fuel control range, engine power is adjusted by the fuel control unit and the power-turbine governor to maintain power turbine speed at a speed slightly lower than the selected rpm.

The propeller governor, shown in Fig. 12.14, is installed at the 12 o'clock position on the front case of the reduction gearbox and is driven by the propeller shaft through an accessory drive shaft. The governor controls the propeller speed and pitch settings as dictated by the cockpit control settings and flight conditions.

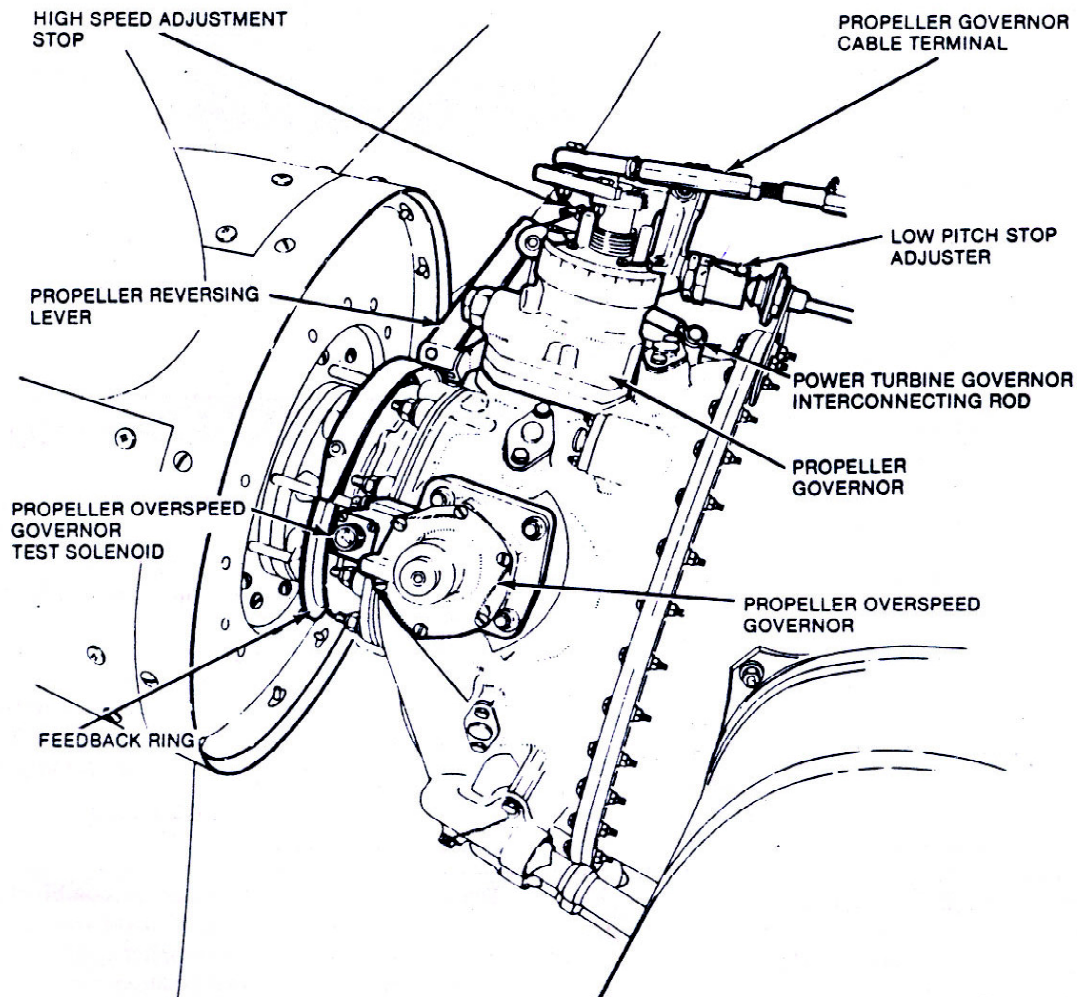

Fig. 12.14. PT6A propeller governor installation.

### Governor Description

The propeller governor is a base-mounted centrifugal type designed for use with hydraulic constant-speed propellers. Pitch of the propeller is varied by the governor to match load torque to engine torque in response to changing flight conditions.

Oil pressure is used to decrease propeller pitch. Pitch change in the increase-pitch direction is accomplished by the use of springs and propeller counterweights on single-acting propellers. The governor is equipped with an integral beta valve, as illustrated in Fig. 12.15, which selects propeller blade angle while the aircraft is operating in the beta control range. It also uses a pneumatic orifice that bleeds compressor discharge from the main fuel control unit, thereby limiting and controlling turbine speed while operating in the constant-speed range. This function is sometimes refer to as Nf governor. On some governors, speed-biasing coil raises the speed setting of the governor to synchronize the "slave" engine with the "master" engine. A feathering valve may be incorporated to allow rapid dumping of oil from the propeller servo when the propeller is feathered. Also, a lock-pitch solenoid (shutoff) valve may be fitted to prevent the propeller from moving into reverse pitch in flight. The valve is energized by switches on the landing gear.

The load imposed on an aircraft turboprop engine is the propeller. The amount of load varies with the angle or pitch of the propeller blades. A propeller in low pitch decreases the load on the engine and allows the engine to increase speed. Constant engine speed, therefore, is achieved by controlling the load on the engine by varying the pitch of the propeller blades.



### Governor Operation

Engine oil is supplied to a gear type engine-driven oil pump in the base of the governor, as shown in Fig. 12.15. Maximum oil pressure in the governor is limited by the governor relief valve. When oil pressure reaches the allowable maximum, the relief valve opens and the oil recirculates through the pump.

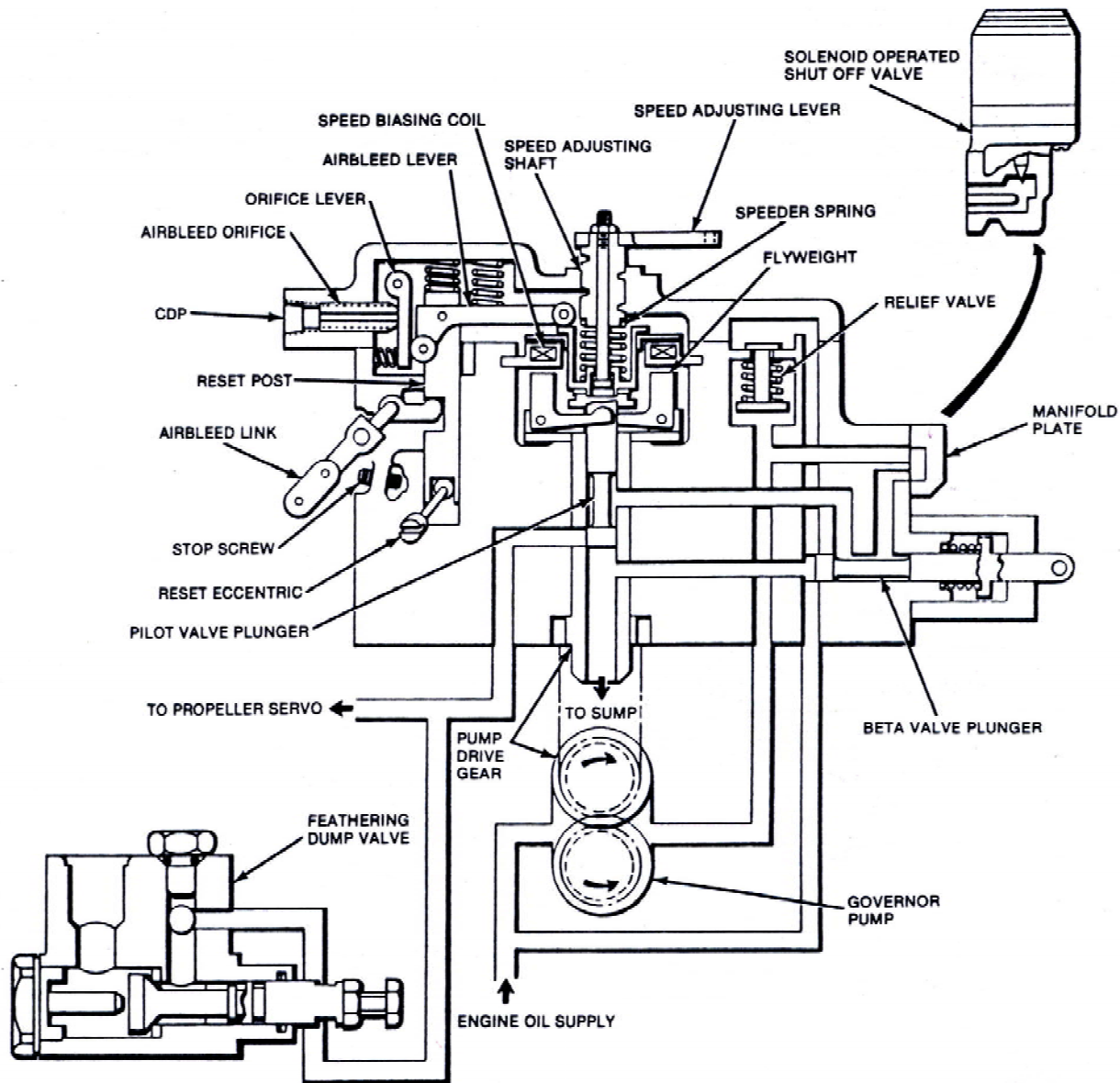

Fig. 12.15. Schematic diagram of propeller governor operation.

### “On speed” Position

The pilot valve plunger moves up and down, as illustrated in Fig. 12.15, in the hollow drive-gear shaft to control the flow of oil to and from the propeller servo. When the pilot valve plunger is centered (i.e., when the plunger covers the oil discharge ports in the drive-gear shaft), no oil flows to or from the propeller servo, but oil is recirculated through the pump. The propeller blade angle and engine speed remain constant. This is the “on-speed” condition. The centrifugal force developed by the rotating fly weights is transformed into an upward force which tends to lift the plunger. This centrifugal force is opposed by the downward force of the speeder spring, which may be varied by means of the speed-adjusting lever. When the opposing forces are equal, the plunger is stationary.

### Underspeed position

An underspeed condition occurs as the result of an increase in propeller load or movement of the control lever in the INCREASE RPM direction. The flyweight force thus becomes less than the speeder-spring force. The flyweights move in, lowering the pilot valve plunger and uncovering the ports in the drive-gear shaft, thus allowing oil to flow to the propeller pitch-changing servo. The propeller blades move in the decrease-pitch direction against the force of the propeller counterweights. With load on the engine reduced, engine speed increases, and the centrifugal force developed by the rotating fly-weights is increased. The flyweight toes lift the pilot valve plunger to cover the control ports and shut off the flow of oil. The forces acting on the engine-governor-propeller combination are again balanced, and the engine has returned to the speed called for by the governor control lever setting.

**Overspeed position**

An overspeed condition occurs as the result of a decrease in propeller load or movement of the control level in the DECREASE RPM direction. The flyweight force thus becomes greater than the speeder-spring force. The flyweights move out, raising the pilot valve plunger and aligning the ports, through the governor, to the sump. As the propeller blades move in the increase-pitch direction, load on the engine is increased, and engine speed is reduced. The centrifugal force lowers the pilot valve plunger to its centered position. The pilot valve plunger once more covers the ports in the drive-gear shaft, blocking the flow of oil to or from the propeller servo, and the system is again in equilibrium.

**Feathering**

When the governor speed adjusting lever is pulled back against the “minimum rpm” stop, the pilot valve plunger is raised by the pilot valve lift rod. This allows the propeller counterweights and feathering spring ( in the propeller hub) to force the oil out of the propeller servo into the engine sump. The blades then rotate to the feathered position.

**Reversing Operation**

The propeller governor beta valve plunger is operated by the propeller-reversing linkage (through the propeller control cam assembly) and the beta lever. Reverse pitch is obtained by moving the power lever aft of the FIGHT IDLE position. The amount of reverse pitch applied is controlled by how far aft the pilot moves the power lever.

During reverse operation, the propeller governor supplies more oil, via the beta valve, to the propeller servo piston. When the amount of reverse pitch called for by the pilot is reached, the beta ring provides feedback through the carbon block to the beta lever. This movement of the beta lever pulls the beta valve plunger outward and blocks the propeller oil supply, thus preventing further pitch change. As the blade angle reaches a reverse pitch position, engine speed is increased by the control cam assembly to provide enough power for the reverse blade angle selected.

When a blade angle is selected by the pilot, the propeller comes out of the beta range. The blade pitch will automatically increase to maintain the speed setting which has been established by the propeller governor speed-adjusting lever.



# INDEX

## A

- Acceleration 77, 81
- Accelerator Pump 77
- Accessories 14
- Accessories Section 35
- Accessory cooling 67
- Additional Controls 99
  - Advantages 39
  - Aerodynamic (Advantages) 39
  - After burning 35
- Air Filters 84
  - Air Adapters 30
  - Air Cooling 7
  - Air cooling 66
  - Air Inlet Icing 23
  - Air Inlet Vortex Destroyer 23
  - Air Starter 48
- Air-cooling of Turbine Engines 66
  - American Method 115
- Animal lubricants 64
- Annular Combustion Chamber 32
- Anti-Knock Rating 70
- Automatic Mixture Control 77
- Available Supply Of Compressed Air 39
- Axial Flow Compressor 24
- Axial Flow V/S Centrifugal Flow 40

## B

- Base Mounted And Flange Mounted Magnetos 57
- Basic Differences - Gas Turbine V/S Reciprocating 39
  - Basic Engine 112
  - Basic Operation 79
  - Bell Mouth Air Inlet 22
- 'Beta' Control 105
- Brake Power 15
- Brayton Cycle 45
  - Breather 62
- Breather System 62
- British Method 115
- Burners 99

## C

- Calorific Value 70
- Cam Drums 12
- Camshafts 12
- Capacitance 58
- Carburettor Icing 84
- carburettor.Fuel Control Unit 77
- Cartridge 48
- Centrifugal breather 60
- Centrifugal Impellers 85
  - Centrifugal Pumps 14
- Characteristic of aircraft lubricating oil 64
- Chemical Elements 36
- Chrome-Nickel Steels 37
- Chromium Steels 37
- Classification of Lubricants 64
  - Cobalt Base Alloys 38
  - Combination Hand And Electric Inertia Starters 54
  - Combined acceleration and speed control 98

- Combustion Chamber 30
  - Combustion Process 30
  - Coming in speed of magneto 56
- Comparative Advantages and Disadvantages of Gas Tu 39
- Comparison Between Brayton Cycle and Otto Cycle 45
- Comparison Between Thrust and Horsepower 41
- Components and Characteristics of Lubricating Syst 65
  - Compression Stroke 1
  - Compressor control 99
  - Compressors 23
  - Connecting Rods 10
  - Construction 24, 29, 34
- Constructional Details of Gas Turbine 21
- Cooling 66
  - Corrosive Effects 70
  - Cowlings and Baffles 112
  - Crankcases 8
  - Crankshafts 8
  - Cylinders 9

**D**

- Decreased Fire Hazard 39
- Definition 64
- Diaphragm Pumps 14
- Difference Between Turbo Jet and Turbo Prop 21
- Difference Between Turbo Prop and Turbo Shaft 21
  - Differences Between Various types of engines 20
- Diffusers 24, 30
- Direct Fuel Injection 81
  - Direct Cranking Electric Starter 53
- Direct Cranking Systems 53
  - Direct Hand Cranking Starter 53
- Disadvantages 39
  - Disadvantages 39, 40
  - Discharge Nozzle 77, 83
  - Divided Entry Duct 22
- Double-acting Propeller 103

**E**

- Effect of After Burning on Engine Thrust 42
- Effect of Altitude 43
- Effect of Climate 43
- Effect of Forward Speed 42
  - Electric 48
  - Electric Motors For Inertia Starters 54
  - Electrical Heating System 108
  - Electrical Heating Systems 109
  - Electrical System 113
- Electrically Operated Propellers 105
- Engine Icing 83
  - Engine Components 8
  - Engine Cooling 6
  - Engine Cycle 4
  - Engine Driven Accessories 35
  - Engine Efficiency 6
  - Engine Fuel System 112
- Engine Layout 2
  - Engine Mountings 112
  - Engine Testing 111
- Engine Thrust in Flight 42
- Engine Thrust on the Test Bench 41
  - Essential Parts of an Ignition System 55
  - Exhaust Stroke 1
  - Exhaust System 112
  - External cooling and ventilation 67
  - External Protection 116

External Treatment 117  
Externally-driven Superchargers 88

**F**

Faster Acceleration of the Rotor Section 41  
Faster Installation and Removal 40  
Feathering 105  
Feathering propellers 101  
Filter 63  
Fine Pitch Stops 104  
Fireproof Bulkhead 113  
Fixed pitch propellers 101  
Flashover: 58  
Float-chamber Carburettors 72  
Flow control 97  
Fluid lubricants 64  
Foreign Object Damage 23  
Freedom From Vibration 39  
Fuel 70  
Fuel Consumption (Neutral Characteristics) 40  
Fuel Consumption and Power-to-weight Relationship 44  
Fuel Control Systems 94  
Fuel Manifold Valve 83  
Fuel Pump 94  
Fuel Pump 81  
Fuel pump control systems 94  
Fuel Pumps 77  
Fuel System Inhibiting 116  
Fuel used in piston engines 8  
Fuel/Air Control Unit 81  
Full Flow System 61  
Functions 65

**G**

Gas Turbine 49  
Gasolene 8  
Gear Pumps 14  
General 85, 100  
General 107  
General (Advantages) 40  
General Condition of Engine 111  
Gmr-235 38  
Gravity Method 116  
Ground Running 51

**H**

Hand Inertia Starter 54  
Harness assembly 56  
High Cost of Manufacture 39  
High Energy Ignition Unit 49  
High Specific Fuel Consumption At Low Airspeeds 39  
High Starting Power Requirements 39  
High voltage corona 58  
High-tension Ignition System 55  
Horizontally Opposed Engines: 4  
Hot Air System 107, 108  
Hydraulic 49

**I**

Idling 73, 79  
Igniter Plug 49  
Ignition Boosters 57  
Ignition Lead 51  
Ignition of the Jet Engines 49  
Ignition switch and the primary circuits 56  
Ignition System For Piston Engines 55

- Impact Icing 84
- Impellers 24
- In-Line Engine 4
- Inconel 38
- Indicated Power 15
- Induction Stroke 1
- Inefficient Operation At Low Power Levels 39
- Inertia Starters 53
- Injection Carburettors 77
- Inspection 117
  - Installation and maintenance 108
- Installed Turbine Engines 116
- Installed Piston Engines 115
  - Intake Duct 112
  - Internal cooling 66
  - Internal Protection 115
- Internally-driven Superchargers 86
- Introduction 48, 60, 70, 94, 107, 115
  - Introduction 30, 33, 66
  - Iso-Propyl Nitrate 48

**L**

- Lifed Items 111
- Limitations 20
  - Liquid Cooling 7
  - Liquid cooling 66
- Liquid-propellant Rocket Engine & Solid-propellant 46
  - Locations 35
  - Long Term Storage 115
  - Long-term Storage 117
  - Low tension and high tension magnetos 57
- Low-tension Ignition 58
  - Lower Oil Consumption 39
  - Lower Specific Fuel Consumption 40
  - Lower Specific Weight 39, 40
- Lubricant Requirements And Functions 64
  - Lubrication 113
- Lubrication Oils 63
- Lubrication Systems 60
  - Lubrication Systems 117

**M**

- Mach Number 43
- Magnetic plugs 61
- Magneto Ignition 55
- Magneto sparking order 56
- Main Metering System 73
- Main Oil Pump 62
- Major Components Of Gas Turbine Engines 21
  - Material For Gas Turbine Engines 36
  - Mean Effective Pressure 15
  - Mechanical Efficiency 6
  - Metal propellers 102
- Methods of Jet Propulsion 18
- Methods of Starting 48
  - Mineral lubricants 64
- Mixture Requirements 70
  - Mixture Control 81
  - Mixture Controls 74
  - Moisture 58
  - Momentary Overspeed up to 2% 113
  - More Effective Water Injection 40
  - Motoring Method 116
  - Multiple Combustion Chamber 31

**N**

- Negligible Cooling Air Required 39
- Nickel Base Alloys 38
- No Carburettors 39
- No Spark Plugs Required Except For Starting 39
- Non-routine Inspections 113
- Normal Operation 103
- Nozzle Guide Vanes 34

**O**

- Oil coolers 61
- Oil Filter 62
- Oil System 112
- Operating Conditions 29
- Operation 17, 60
- Operation of Afterburning 36
- Operation of low tension ignition system 58
- Otto Cycle 4
- Output 40
- Overboosting 114
- Overboosting exceeding 5 inHg [2(1/2) lbf/in<sup>2</sup>] 114
- Overboosting not exceeding 2 inHg (1 lbf/in<sup>2</sup>) 114
- Overboosting not exceeding 5 inHg [2(1/2) lbf/in<sup>2</sup>] 114
- Overspeed higher than 10% 114
- Overspeeding 113
- Overspeeding between 5% and 10% 114
- Overspeeding Up to 5% 114

**P**

- Performance Comparison 40
- Performance of Gas Turbine Engines 41
- Pipes 113
- Piston engine 66
- piston engine superchargers 85
- Pistons 11
- Polarity Or Direction Of Sparks 55
- Poppet Valves 11
- Power Calculation and Measurement 15
- Power Control 16
- Power Enrichment 75
- Power Section Lubrication System 62
- Power Stroke 1
- Pressure controller 96
- Pressure Gauge 83
- Pressure lubrication 65
- Pressure Pump 63
- Pressure relief valve system 60
- Pressure Rig Method 116
- Pressure system 62
- Priming System 84
- Principle components of a lubrication system 65
- Principle of Jet Propulsion 18
- Principles Governing The Operation of the Inertia 53
- Principles of Operation 1
- Principles of Operation 23, 27
- Process 1-2 : Intake 4
- Process 2-3 : Compression 4
- Process 3-4 : Combustion 4
- Process 4-5 : Expansion 4
- Process 5-6 : Blow down 4
- Process 6-1 : Exhaust 5
- Propeller Balance 101
- Propeller Control 102
- Propeller Reduction Gear 13
- Propulsive Efficiency 44
- Pulse Jet 18

Pumps 14  
Purpose 32  
Push Rods 13

**R**

Radial Engine 2  
Ram Jet 18  
Ram Ratio 42  
Reasons for development of low tension ignition 58  
Recirculatory system 60  
Reduction Gear Lubricating System 63  
Regulator 77  
Relighting 51  
Reversible pitch propellers 101  
Reversing 105  
Rockers 13  
Rocket Engine 19  
Rocket Engines 46  
Rotating magnetos and inductor rotor magnetos 57  
Rotor Blades 29  
Rotors 29  
Routine Maintenance 111

**S**

Safety Precautions 51  
Scavange Relief Valve 62  
Scavange System 62  
Semisolid lubricants 64  
Sequence of starting of a gas turbine engine 51  
Shock-loading 114  
Short-term Storage 116  
Simple Manufacture And Fewer Parts 40  
Simplicity of Control 39  
Single acting propellers 102  
Single and double type magnetos 57  
Single Entry 22  
Sintered Mesh Porous Media 38  
Sleeve Valves 11  
Slow Acceleration From Minimum Speed 39  
Smaller Diameter Or Frontal Area. 40  
Special Requirements 116  
Splash Lubrication And Combination System 65  
Starting 52  
Stator Blades 29  
Stopping 52  
Supercharger controls 86  
Supercharger Drives 86  
Susceptibility To Damage By Foreign Material 39  
Synthetic lubricants 64

**T**

Tappets 12  
Testing 52  
The Booster Coil 57  
The Centrifugal Flow Compressor 23  
The Diffuser and Air Adaptor 30  
The distributor 55  
The Exhaust Cone 34  
The Hastelloys 38  
The Induction Vibrator 58  
The Inlet Duct And Guide Vanes 21  
The Nimonic 38  
The thrust reverser 34  
The Udimet 38  
Thermal Efficiency 6  
Three Scavange Pumps 62



|   |     |
|---|-----|
| Throttle Body                                     | 77  |
| Throttle Valve                                    | 77  |
| Thrust Increase                                   | 36  |
| Torque Meters                                     | 17  |
| Total Loss (Expendable) System                    | 61  |
| Turbine   | 33  |
| Turbine Blades                                    | 34  |
| Turbine Disc                                      | 34  |
| Turbine gas temperature control                   | 99  |
| Turbine Nozzle and Nozzle Diaphragm               | 32  |
| Turbo Annular Combustion Chamber                  | 31  |
| Two Pressure Relief Valves                        | 63  |
| Two Secavange Pumps                               | 63  |
| Types of Combustion Chamber                       | 31  |
| Types of Jet Engines (Gas Turbine)                | 19  |
| Types of Magneto                                  | 57  |
| Types of Propellers                               | 101 |
| Types of Starting Systems                         | 53  |
| Typical Lubrication System of a Turbo Propeller   | 62  |
| Typical lubrication system                        | 65  |
| Typical Lubrication System of a Turbo Fan Engine: | 61  |

**U**

|  |     |
|--|-----|
| Unfeathering                             | 105 |
| Uninstalled Engines (Piston and Turbine) | 117 |

**V**

|                                   |          |
|-----------------------------------|----------|
| V-Type                            | 4        |
| Valve Operating Mechanism         | 12       |
| Valves                            | 11       |
| Variable Geometry Duct            | 22       |
| Variable pitch propellers         | 101, 102 |
| Variations In Alloy Properties    | 38       |
| Variations In Gas Turbine Designs | 20       |
| Venturis                          | 77       |
| Volatility                        | 70       |
| Volumetric Efficiency             | 6        |

**W**

|                     |     |
|---------------------|-----|
| Waspalloy           | 38  |
| Weight (Advantages) | 40  |
| Wooden propellers   | 101 |

